

FESTO

**Distribution station
Assembly
Instructions**

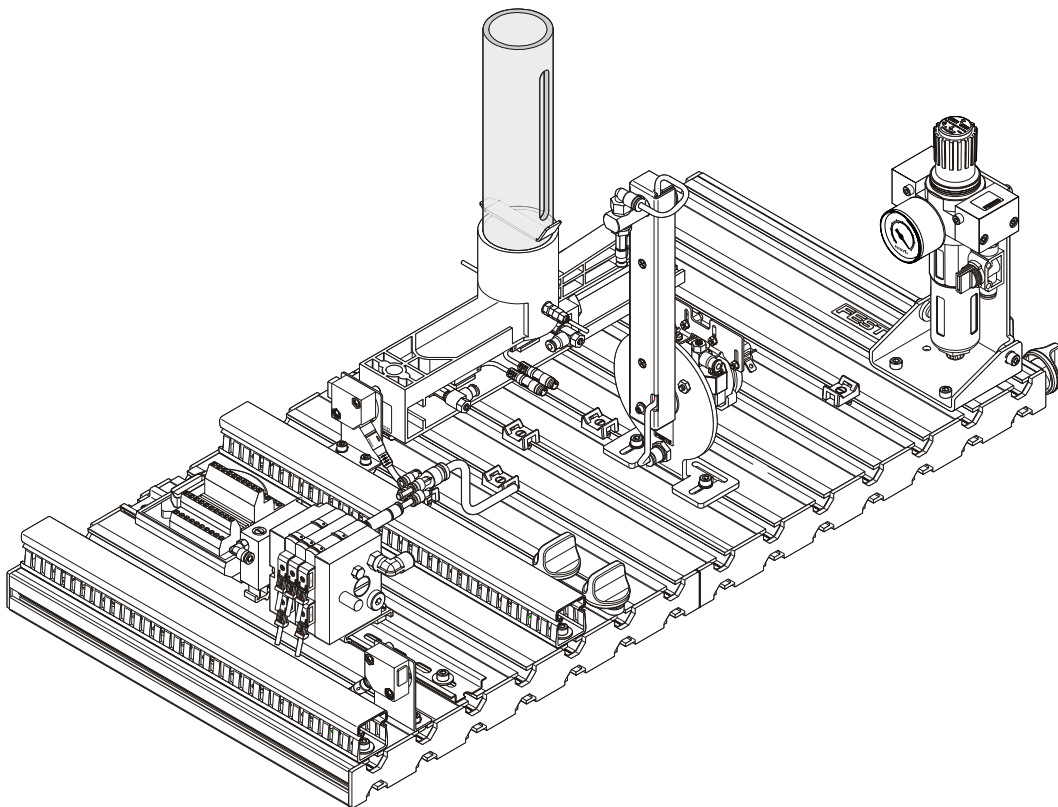

Intended use

This station has been developed and produced exclusively for vocational and further training in the field of automation and communication. The training authority and/or the instructors are to ensure that trainees observe the safety instructions described in the manual provided.

Festo Didactic herewith rules out all liability for damage or injury to trainees, the training authority or other third parties which may occur during the use/operation of this equipment other than purely in a training situation, unless it can be proved that Festo Didactic has caused such damage or injury through malicious intent or gross negligence.

Description	MONT.ANLEIT
Designation:	D:MP-MA-S-VERT-1-GB
Status:	11/2002
Author:	Frank Ebel
Graphics:	Doris Schwarzenberger, Albert Sigel
Layout:	11/2002

© Festo Didactic GmbH & Co., D-73770 Denkendorf, 2002

Internet: www.festo.com/didactic

e-mail: did@festo.com

The copying, distribution and utilisation of this document, as well as the communication of its contents to others without the express authorisation of Festo Didactic is prohibited. Offenders will be held liable for the payment of damages. All rights reserved, in particular the right to carry out patent, utility model or ornamental design registration

Contents

1.	Notes on safety	5
2.	Short description	6
3.	Views and tools	8
3.1	Views	8
3.2	Tools	9
4.	Assembling the station	10
4.1	Step 1	10
4.2	Step 2	11
4.3	Step 3	12
4.4	Step 4	13
4.5	Step 5	14
4.6	Step 6	15
4.7	Step 7	17
4.8	Step 8	18
4.9	Step 9	19

Contents

1. Notes on safety

In the interests of your own safety, please observe the following safety instructions:



General

- Trainees must only work on a station under the supervision of an instructor.
- Observe the data in the data sheets for the individual components, particularly all safety instructions!

Electrical

- Electrical connections are to be wired-up or disconnected only when the power supply is turned off!
- Use only extra-low-voltages of up to max. 24 V DC.

Pneumatic

- Do not exceed the maximum permissible pressure of 8 bar (800 kPa).
- Do not switch on the compressed air supply until you have established and secured all tubing connections.
- Do not disconnect air lines under pressure.
- Particular care is to be taken when switching on the compressed air supply. Cylinders may advance or retract as the compressed air is switched on.

Mechanical

- Attach all components securely on the mounting plate.
- No manual intervention is to take place unless the machine is at rest.

2. Short description

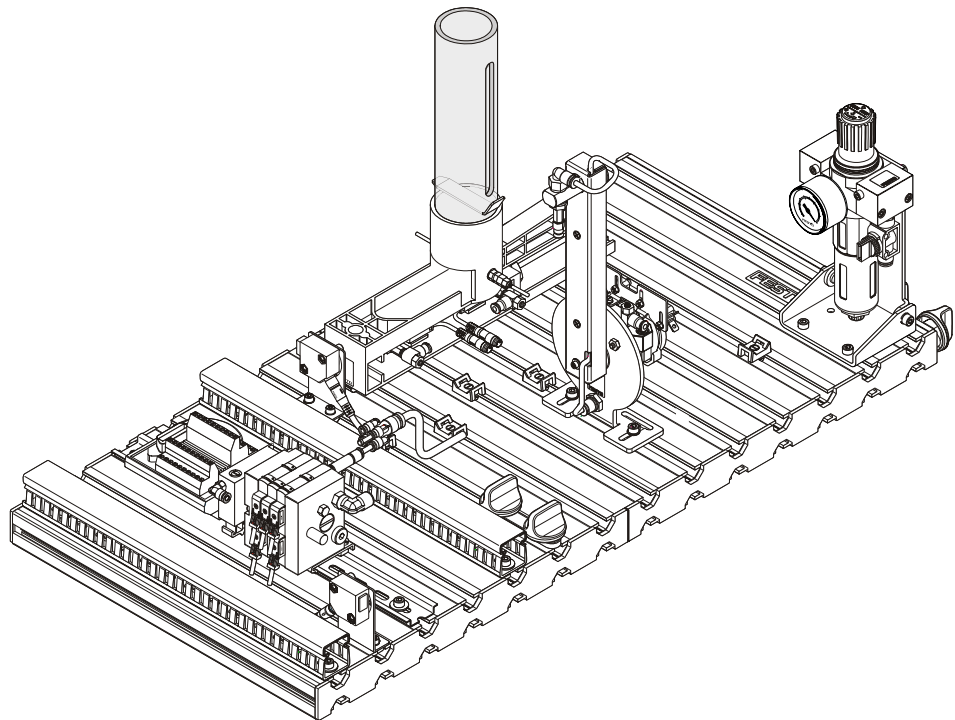

View of the Distribution station

The Distribution station is a feed device. According to VDI 3240, feed devices are defined as units which fulfill the function of bunkering, sorting and feeding of components. In addition, feed devices can facilitate the sorting of components according to various sorting characteristics (shape, weight etc. of the component).

The following are feed devices:

- Magazines with feed limiting,
- Vibratory bowl feeder,
- Inclined conveyors and
- Hoppers with sorting devices.

Workpieces handled by feed devices are

- Electroplated parts,
- Shaped parts made of plastic,
- Punched parts and
- Turned components.

Short description

The function fo the Distribution station is

- to separate out workpieces from a magazine and
- to transfer workpieces by means of a rotary drive using a suction cup.

The Distribution station consists of the following:

- Stack magazine module
- Changer module
- Profile plate

- Trolley
- Control console
- PLC board

3. Views and tools

3.1 Views

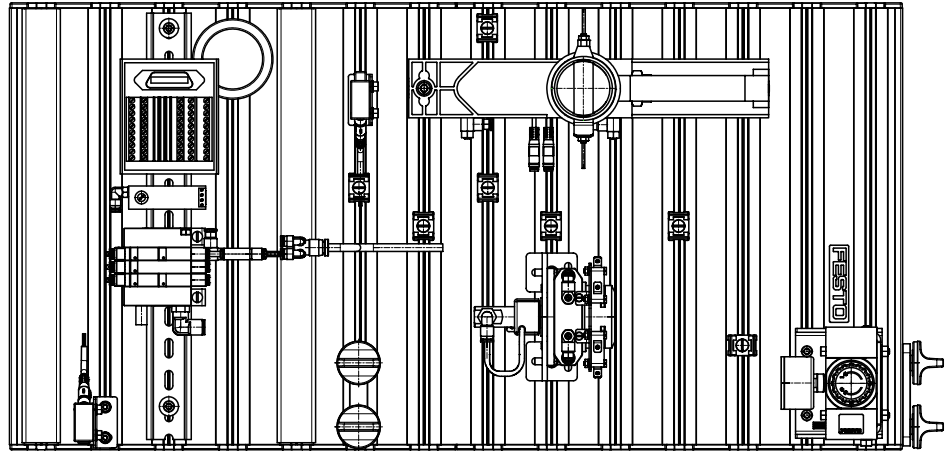

Distribution station, plan view

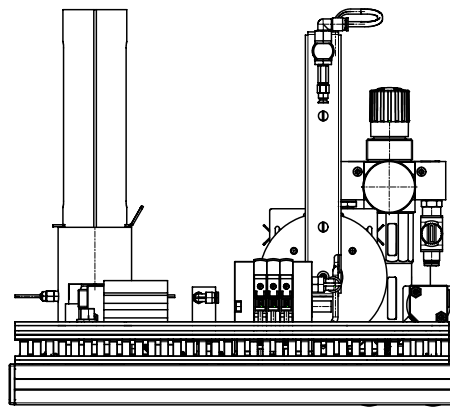

Distribution station, r.h. side view

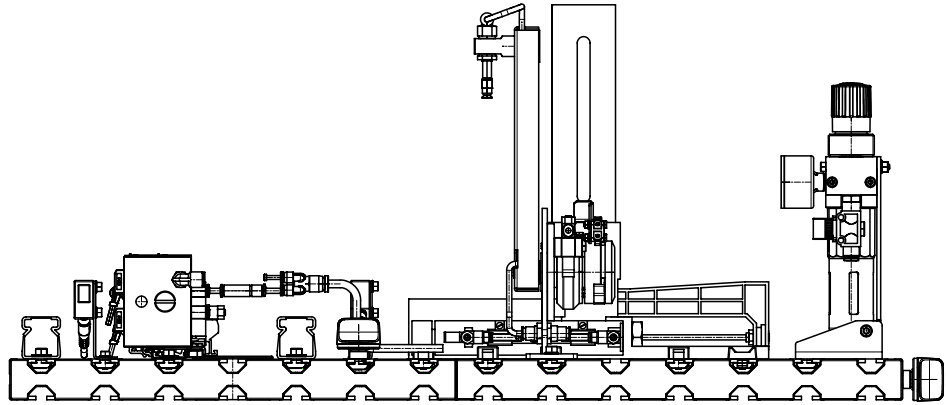

Distribution station, front view

3.2

Required tools

Tube spanner, 9 x 10 mm

Open-ended spanners 6 x 7, 12 x 13, 22 x 24 mm

Slot-head screwdriver, 3.5 mm

Allen key, 5 mm

4. Assembling the station

4.1 Step 1

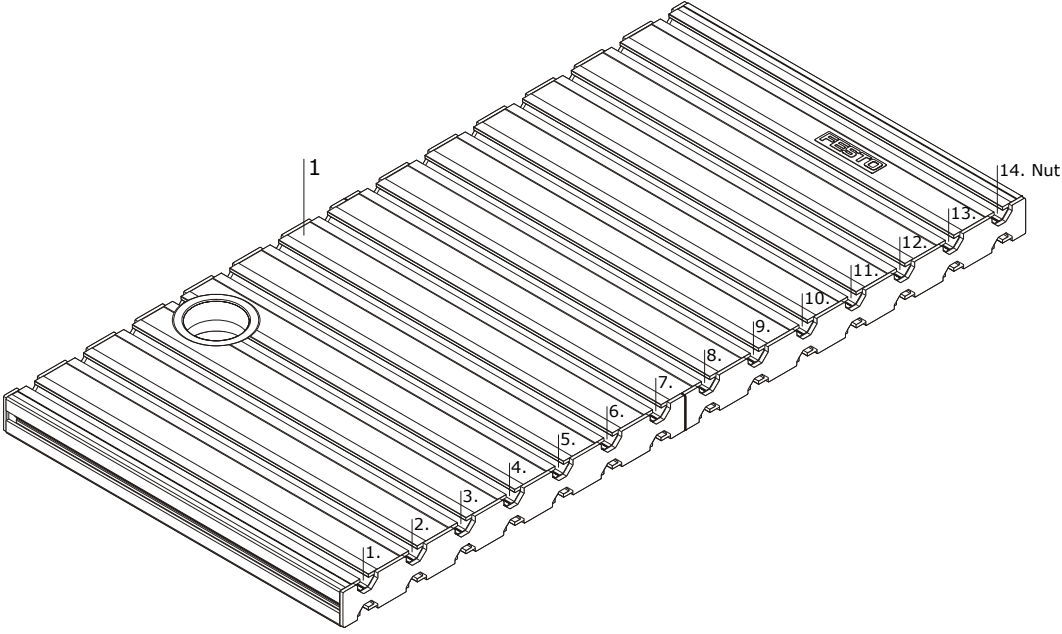

1 Profile plate

4.2
Step 2

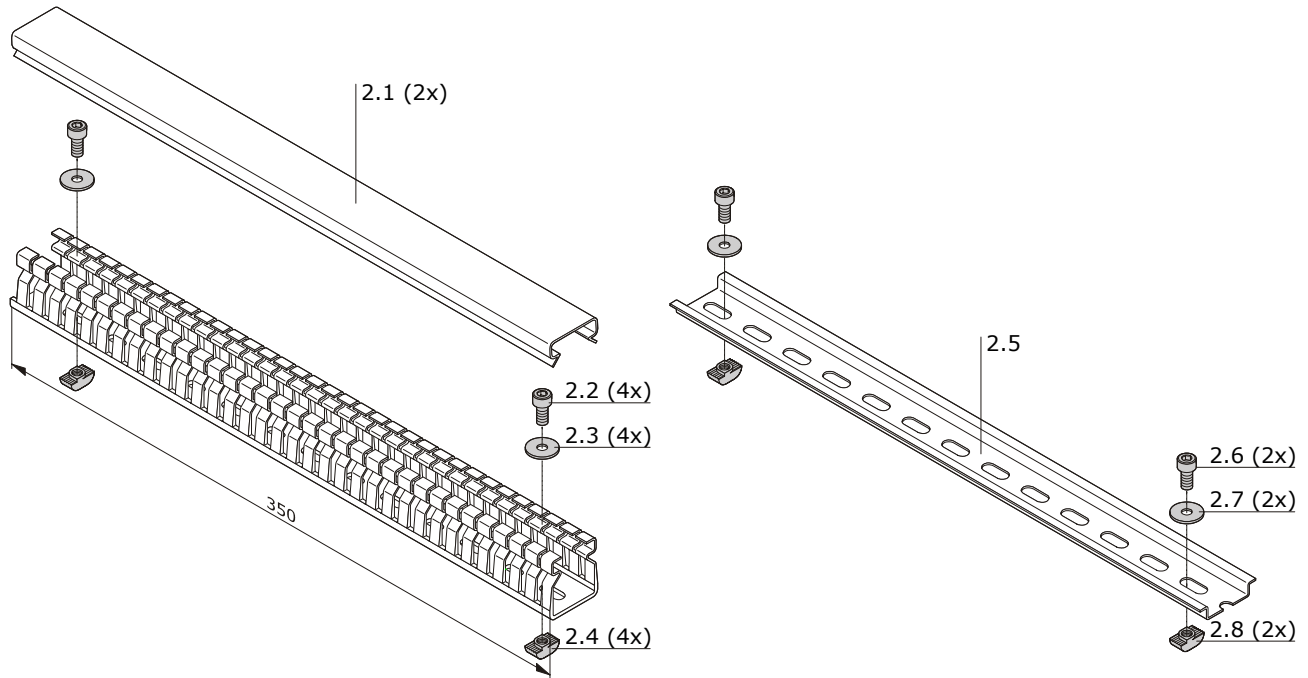

- 2.1 Cable duct
- 2.2 Socket-head screw M5 x 10
- 2.3 Washer B5.3
- 2.4 T-head nut M5-32
- 2.5 Mounting rail
- 2.6 Socket-head screw M5 x 10
- 2.7 Washer B5.3
- 2.8 T-head nut M5-32

4.3
Step 3

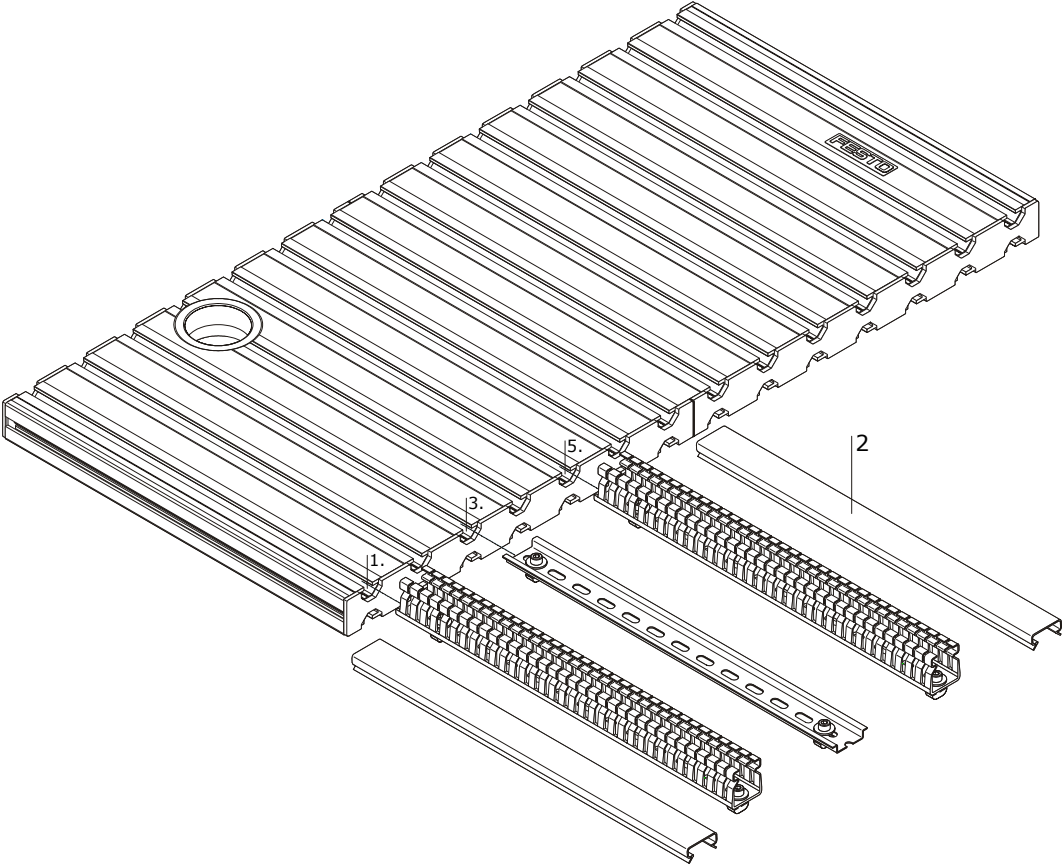

2 Mounting the electrical system

Assembling the station

4.4 Step 4

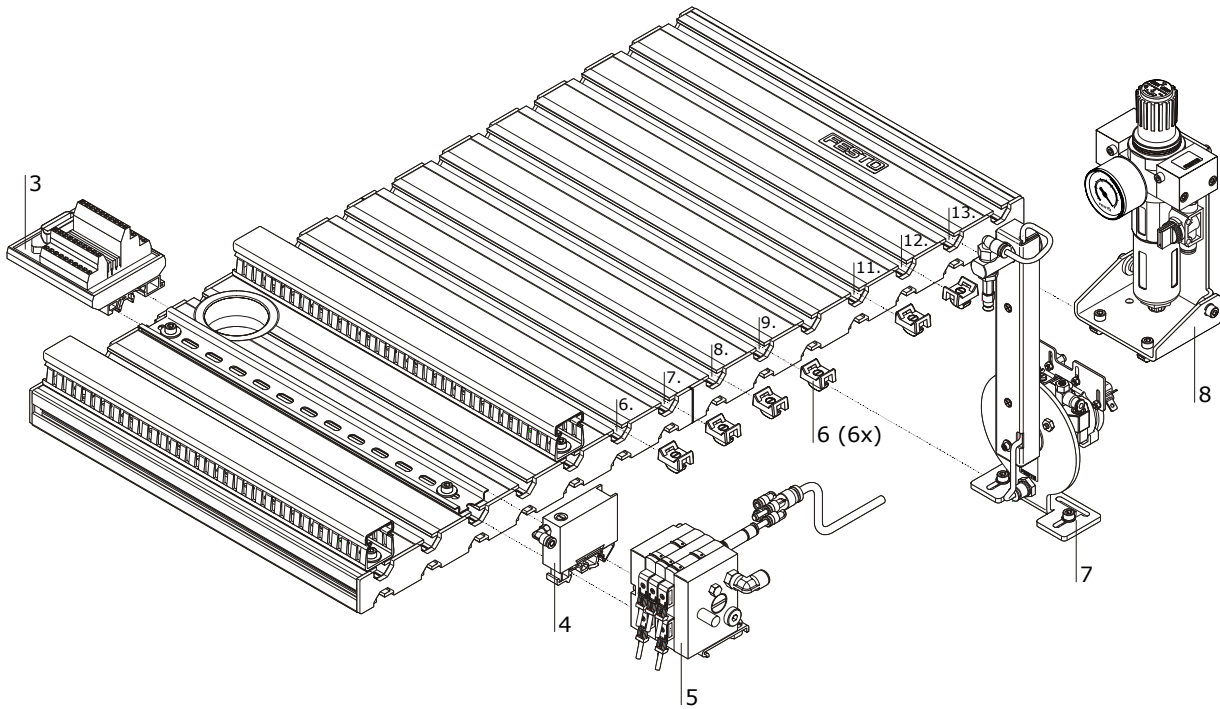

- 3 I/O terminal
- 4 Vacuum switch
- 5 CP valve terminal
- 6 Cable clip (6x)
- 7 Changer module
- 8 Service unit

4.5
Step 5

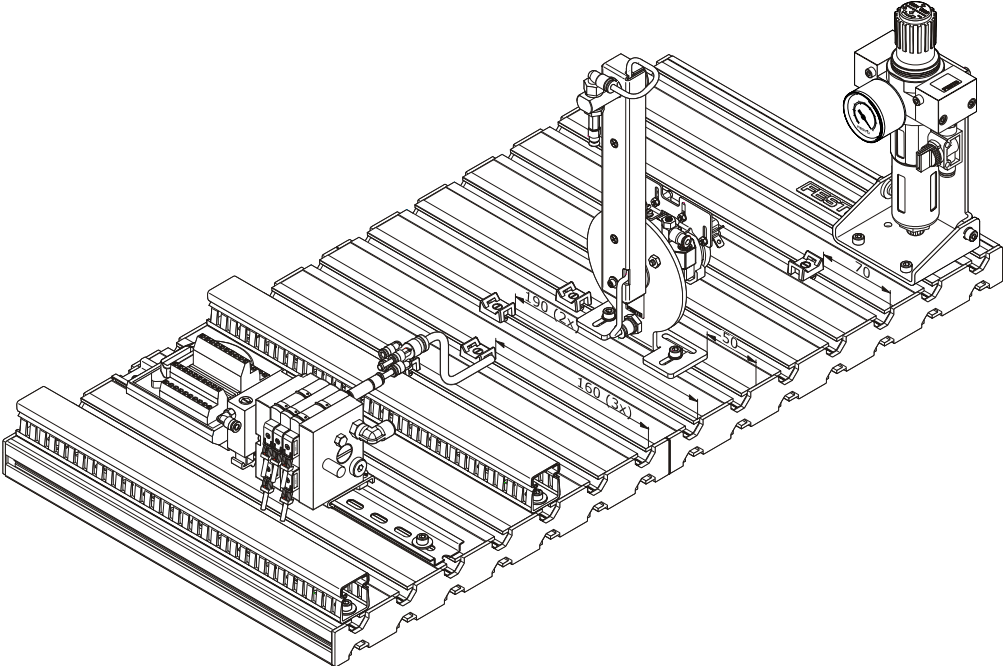

Position of Changer module and cable clips

Assembling the station

4.6

Step 6

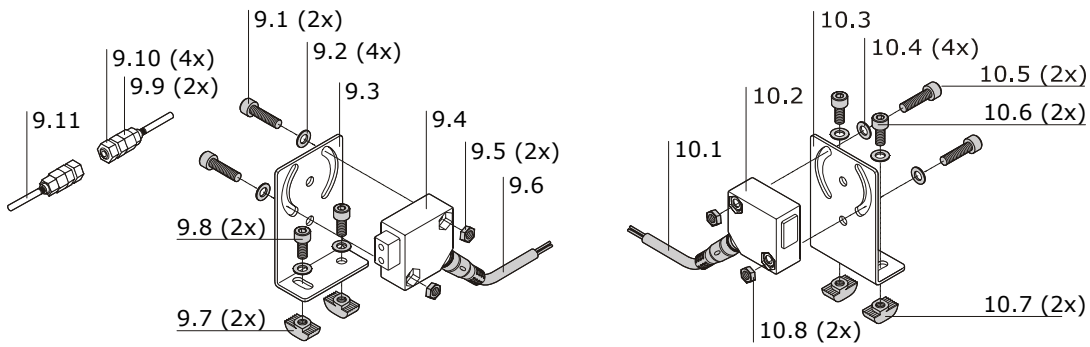

9.1 Socket head screw M 4 x 16 (2x)

9.2 Washer B 4.3 (4x)

9.3 Mounting bracket

9.4 Fibre optic device

9.5 Nut M 4 (2x)

9.6 Socket connector cable

9.7 T-head nut M 4-32 (2x)

9.8 Socket head screw M 4 x 10 (2x)

9.9 Adapter(2x)

9.10 Nut M 5 (4x)

9.11 Fibre optic cable "Light barrier"

Assembling the station

- 10.1 Socket connector cable
- 10.2 StationLink receiver
- 10.3 Mounting bracket
- 10.4 Washer B 4.3 (4x)
- 10.5 Socket head screw M 4 x 16 (2x)
- 10.6 Socket head screw M 4 x 10 (2x)
- 10.7 T-head nut M 4-32 (2x)
- 10.8 Nut M 4 (2x)

Assembling the station

4.7 Step 7

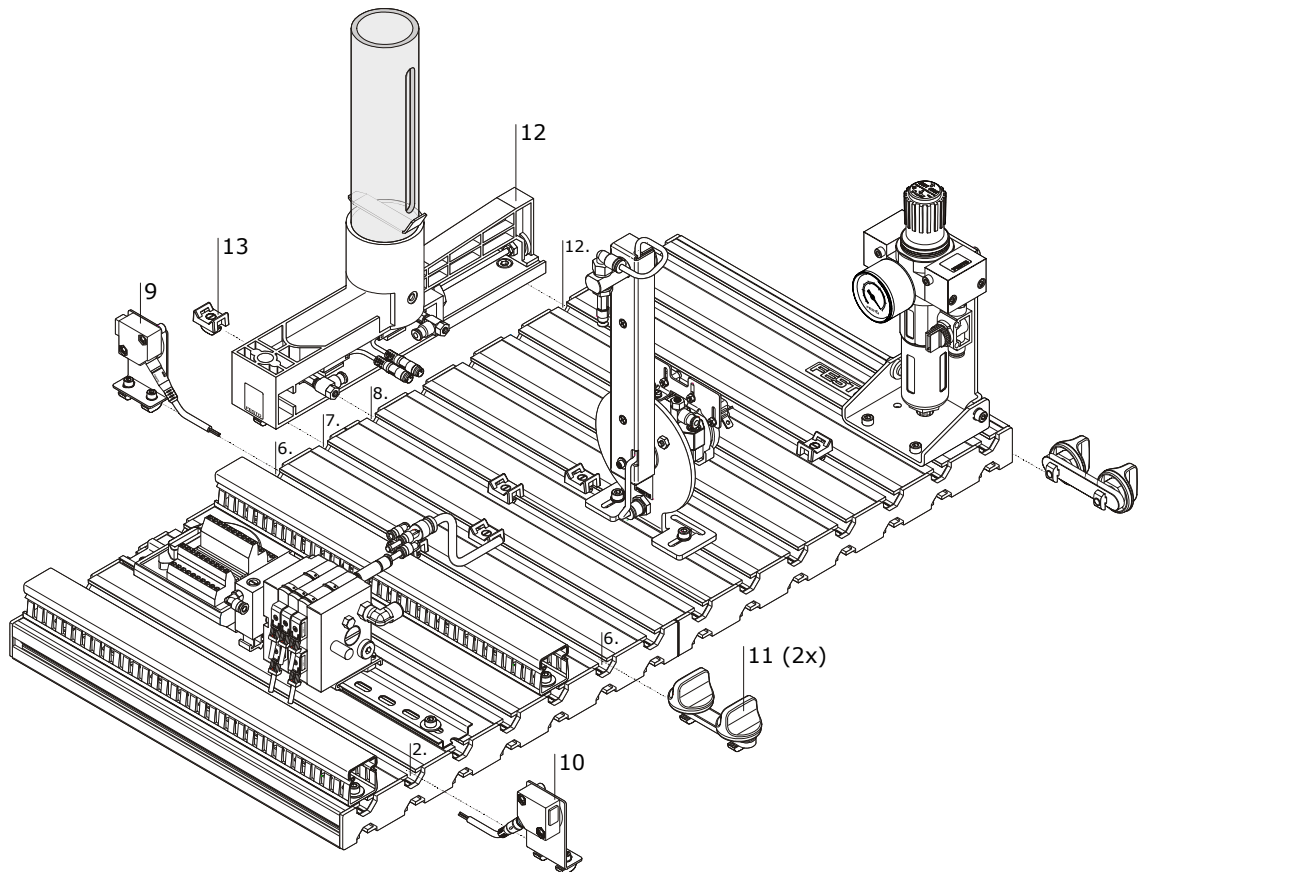

- 9 Fibre optic device
- 10 StationLink receiver
- 11 Connector (2x)
- 12 Stack magazine module
- 13 Cable clip

4.8
Step 8

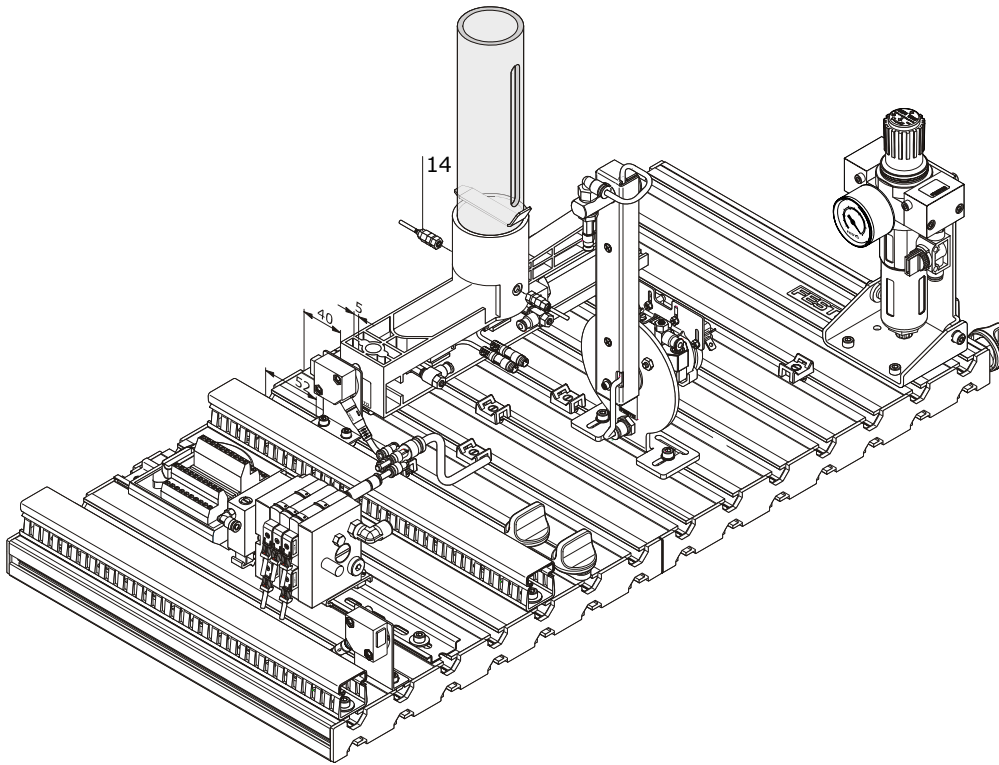

Complete assembling of Stack magazine module and cable clips

14 Fibre optic cable “Light barrier”

Assembling the station

4.9
Step 9

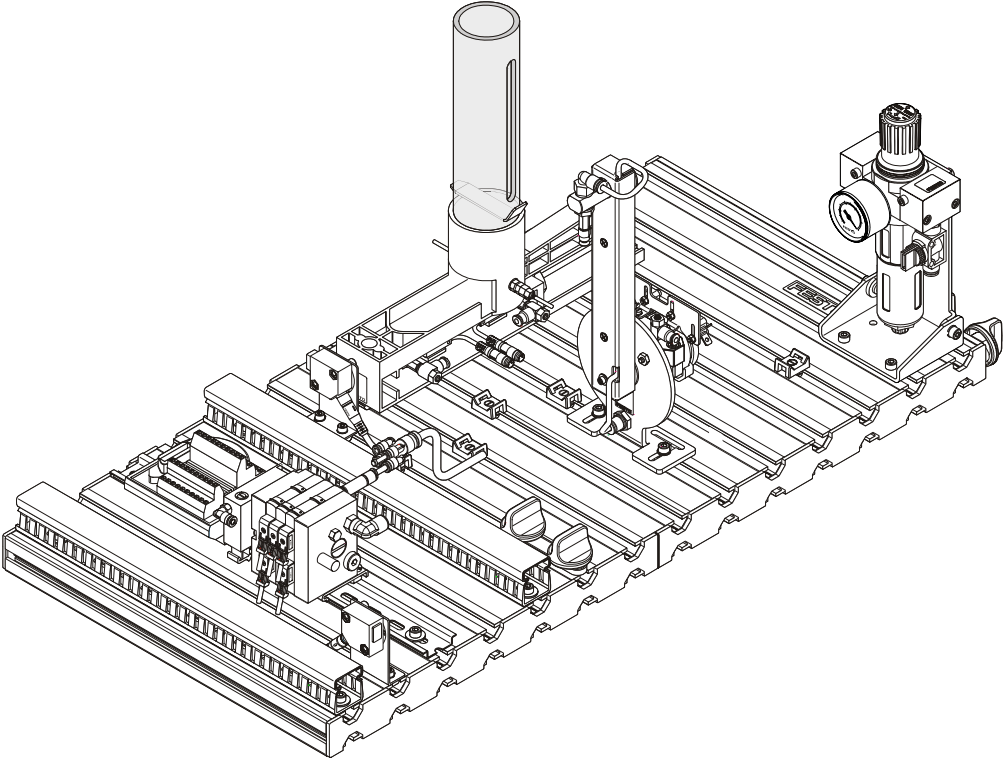

Station completely assembled

Assembling the station