

# Hydraulics

## Basic Level

D. Merkle • B. Schrader • M. Thomes

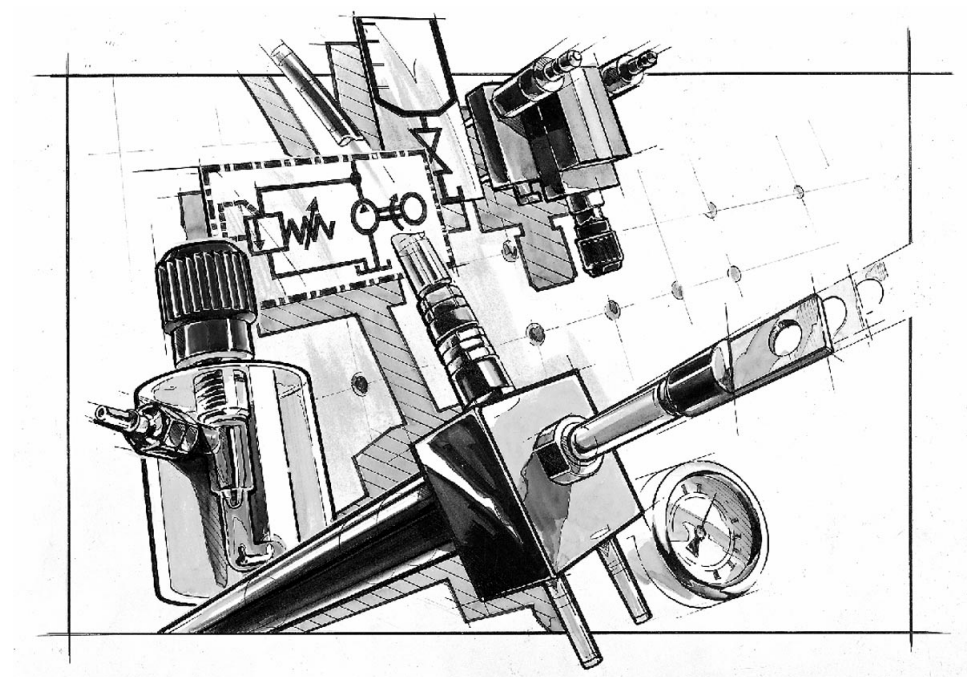

Order no.: 093281  
Description: HYDRAUL.LEHRB  
Designation: D.LB-TP501-1-GB  
Edition: 2<sup>nd</sup>, revised edition 1/98  
Layout: M. Schwarz  
Authors: D. Merkle, B. Schrader, M. Thomes

© 1998 by Festo Didactic GmbH & Co., Rechbergstraße 3,  
D-73770 Denkendorf

The copying, distribution and utilization of this document as well as the communication of its contents to others without expressed authorization is prohibited. Offenders will be held liable for the payment of damages. All rights reserved, in particular the right to carry out patent, utility model or ornamental design registrations.

<b>Chapter 1 Tasks of a hydraulic installation</b> . . . . .	5
1.1 Stationary hydraulics . . . . .	7
1.2 Mobile hydraulics . . . . .	9
1.3 Comparison of hydraulics with other control media . . . . .	10
<b>Chapter 2 Fundamental physical principles of hydraulics</b> . . . . .	13
2.1 Pressure . . . . .	14
2.2 Pressure transmission . . . . .	20
2.3 Power transmission . . . . .	22
2.4 Displacement transmission . . . . .	25
2.5 Pressure transfer . . . . .	27
2.6 Flow rate . . . . .	29
2.7 Continuity equation . . . . .	31
2.8 Pressure measurement . . . . .	37
2.9 Temperature measurement . . . . .	38
2.10 Measurement of flow rate . . . . .	38
2.11 Types of flow . . . . .	39
2.12 Friction, heat, pressure drop . . . . .	43
2.13 Energy and power . . . . .	50
2.14 Cavitation . . . . .	63
2.15 Throttle points . . . . .	65
<b>Chapter 3 Hydraulic fluid</b> . . . . .	69
3.1 Tasks for hydraulic fluids . . . . .	70
3.2 Types of hydraulic fluid . . . . .	71
3.3 Characteristics and requirements . . . . .	73
3.4 Viscosity . . . . .	74
<b>Chapter 4 Components of a hydraulic system</b> . . . . .	81
4.1 Power supply section . . . . .	82
4.2 Hydraulic fluid . . . . .	82
4.3 Valves . . . . .	86
4.4 Cylinders (linear actuators) . . . . .	86
4.5 Motors (rotary actuators) . . . . .	87

<b>Chapter 5 Graphic and circuit symbols</b> . . . . .	89
5.1 Pumps and motors . . . . .	90
5.2 Directional control valves . . . . .	91
5.3 Methods of actuation . . . . .	93
5.4 Pressure valves . . . . .	95
5.5 Flow control valves . . . . .	97
5.6 Non-return valves . . . . .	98
5.7 Cylinders . . . . .	99
5.8 Transfer of energy and conditioning of the pressure medium . . . . .	101
5.9 Measuring devices . . . . .	102
5.10 Combination of devices . . . . .	102
<b>Chapter 6 Design and representation of a hydraulic system</b> . . . . .	103
6.1 Signal control section . . . . .	105
6.2 Hydraulic power section . . . . .	106
6.3 Positional sketch . . . . .	109
6.4 Circuit diagram . . . . .	110
6.5 Components plus technical data . . . . .	111
6.6 Function diagram . . . . .	113
6.7 Function chart . . . . .	114
<b>Chapter 7 Components of the power supply section</b> . . . . .	115
7.1 Drive . . . . .	117
7.2 Pump . . . . .	119
7.3 Coupling . . . . .	129
7.4 Reservoir . . . . .	129
7.5 Filter . . . . .	132
7.6 Coolers . . . . .	144
7.7 Heaters . . . . .	146

<b>Chapter 8 Valves</b> . . . . .	147
8.1 Nominal sizes . . . . .	148
8.2 Design . . . . .	151
8.3 Poppet valves . . . . .	152
8.4 Spool-valve principle . . . . .	153
8.5 Piston overlap . . . . .	155
8.6 Control edges` . . . . .	160
<b>Chapter 9 Pressure valves</b> . . . . .	163
9.1 Pressure-relief valves . . . . .	165
9.2 Pressure regulators . . . . .	172
<b>Chapter 10 Directional control valves</b> . . . . .	179
10.1 2/2-way valve . . . . .	184
10.2 3/2-way valve . . . . .	188
10.3 4/2-way valve . . . . .	190
10.4 4/3-way valve . . . . .	194
<b>Chapter 11 Non-return valves</b> . . . . .	199
11.1 Non-return valve . . . . .	201
11.2 Piloted non-return valve . . . . .	205
11.3 Piloted double non-return valve . . . . .	209
<b>Chapter 12 Flow control valves</b> . . . . .	213
12.1 Restrictors and orifice valves . . . . .	215
12.2 One-way flow control valve . . . . .	219
12.3 Two-way flow control valves . . . . .	220

<b>Chapter 13 Hydraulic cylinders</b> . . . . .	227
13.1 Single-acting cylinders . . . . .	229
13.2 Double-acting cylinders . . . . .	231
13.3 End position cushioning . . . . .	235
13.4 Seals . . . . .	238
13.5 Types of mounting . . . . .	238
13.6 Exhaust . . . . .	238
13.7 Characteristics . . . . .	239
13.8 Buckling resistance . . . . .	242
13.9 Selecting a cylinder . . . . .	244
<b>Chapter 14 Hydraulic motors</b> . . . . .	249
<b>Chapter 15 Accessories</b> . . . . .	255
15.1 Flexible hoses . . . . .	258
15.2 Pipelines . . . . .	267
15.3 Sub-bases . . . . .	270
15.4 Bleed valves . . . . .	273
15.5 Pressure gauges . . . . .	274
15.6 Pressure sensors . . . . .	276
15.7 Flow measuring instruments . . . . .	277
<b>Chapter 16 Appendix</b> . . . . .	279

# Chapter 1

## Tasks of a hydraulic installation

**Hydraulics**  
What do we mean  
by hydraulics?

Hydraulic systems are used in modern production plants and manufacturing installations.

By hydraulics, we mean the generation of forces and motion using hydraulic fluids.  
The hydraulic fluids represent the medium for power transmission.

The object of this book is to teach you more about hydraulics and its areas of application. We will begin with the latter by listing the main areas for the **application of hydraulics**.

The place held by hydraulics in (modern) automation technology illustrates the wide range of applications for which it can be used.

A basic distinction is made between:

- stationary hydraulics
- and mobile hydraulics

Mobile hydraulic systems move on wheels or tracks, for example, unlike stationary hydraulic systems which remain firmly fixed in one position. A characteristic feature of mobile hydraulics is that the valves are frequently manually operated. In the case of stationary hydraulics, however, mainly solenoid valves are used.

Other areas include **marine**, **mining** and **aircraft** hydraulics. Aircraft hydraulics assumes a special position because safety measures are of such critical importance here. In the next few pages, some typical examples of applications are given to clarify the tasks which can be carried out using hydraulic systems.



The following application areas are important for stationary hydraulics: **1.1 Stationary hydraulics**

- Production and assembly machines of all types
- Transfer lines
- Lifting and conveying devices
- Presses
- Injection moulding machines
- Rolling lines
- Lifts

**Machine tool construction** is a typical application area.

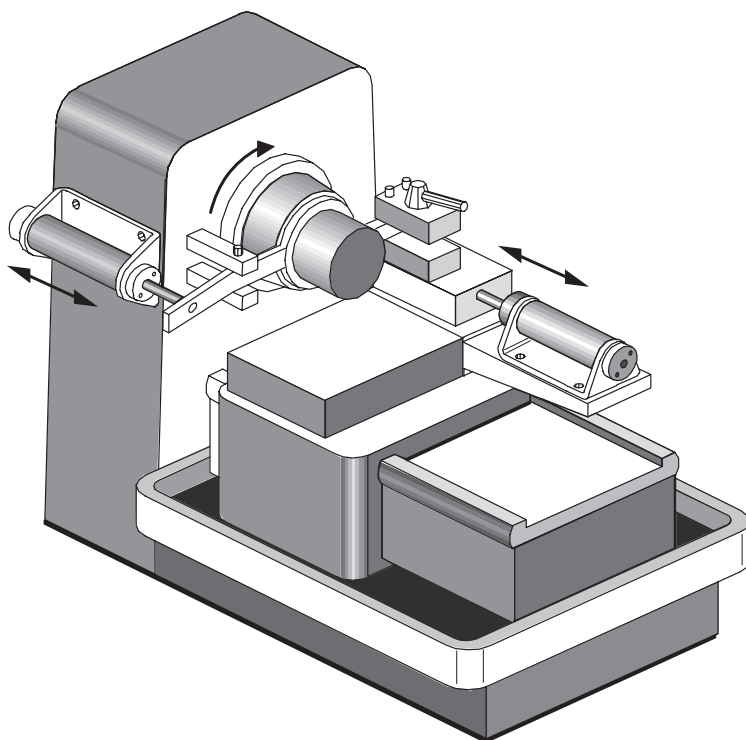

*Lathe*

In modern CNC controlled machine tools, tools and workpieces are clamped by means of hydraulics. Feed and spindle drives may also be effected using hydraulics.

*Press with  
elevated reservoir*

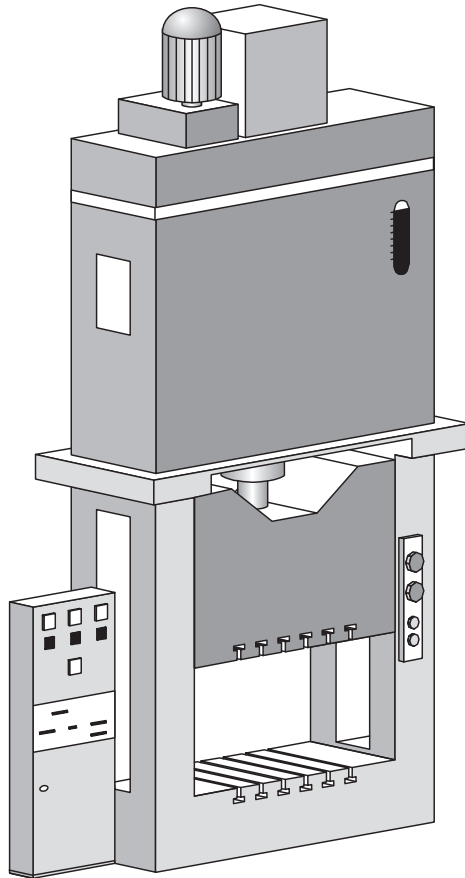

Typical application fields for mobile hydraulics include:

- Construction machinery
- Tippers, excavators, elevating platforms
- Lifting and conveying devices
- Agricultural machinery

There is a wide variety of applications for hydraulics in the construction machinery industry. On an excavator, for example, not only are all working movements (such as lifting, gripping and swivelling movements) generated hydraulically, but the drive mechanism is also controlled by hydraulics. The straight working movements are generated by linear actuators (cylinders) and the rotary movements by rotary actuators (motors, rotary drives).

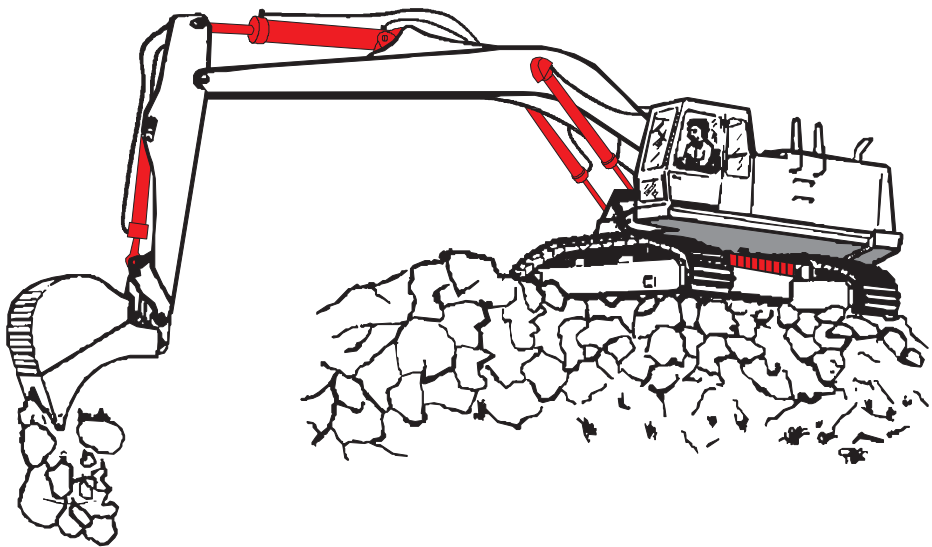

Mobile hydraulics

## 1.2 Mobile hydraulics

### 1.3 Comparison of hydraulics with other control media

There are other technologies besides hydraulics which can be used in the context of control technology for generating forces, movements and signals:

- Mechanics
- Electricity
- Pneumatics

It is important to remember here that each technology has its own preferred application areas. To illustrate this, a table has been drawn up on the next page which compares typical data for the three most commonly used technologies – electricity, pneumatics and hydraulics.

This comparison reveals some important advantages of hydraulics:

- Transmission of large forces using small components, i.e. great power intensity
- Precise positioning
- Start-up under heavy load
- Even movements independent of load, since liquids are scarcely compressible and flow control valves can be used
- Smooth operation and reversal
- Good control and regulation
- Favourable heat dissipation

Compared to other technologies, hydraulics has the following **disadvantages**:

- Pollution of the environment by waste oil (danger of fire or accidents)
- Sensitivity to dirt
- Danger resulting from excessive pressures (severed lines)
- Temperature dependence (change in viscosity)
- Unfavourable efficiency factor

	Electricity	Hydraulics	Pneumatics
Leakage		Contamination	No disadvantages apart from energy loss.
Environmental influences	Risk of explosion in certain areas, insensitive to temperature.	Sensitive in case of temperature fluctuation, risk of fire in case of leakage.	Explosion-proof, insensitive to temperature.
Energy storage	Difficult, only in small quantities using batteries.	Limited, with the help of gases.	Easy
Energy transmission	Unlimited with power loss.	Up to 100 m flow rate $v = 2-6$ m/s, signal speed up to 1000 m/s.	Up to 1000 m flow rate $v = 20-40$ m/s, signal speed 20-40 m/s.
Operating speed		$v = 0,5$ m/s	$v = 1,5$ m/s
Power supply costs	Low	High	Very high
	0,25	:	1
		:	2,5
Linear motion	Difficult and expensive, small forces, speed regulation only possible at great cost.	Simple using cylinders, good speed control, very large forces.	Simple using cylinders, limited forces, speed extremely, load-dependent.
Rotary motion	Simple and powerful.	Simple, high turning moment, low speed.	Simple, inefficient, high speed.
Positioning accuracy	Precision to $\pm 1\mu\text{m}$ and easier to achieve.	Precision of up to $\pm 1\mu\text{m}$ can be achieved depending on expenditure.	Without load change precision of 1/10 mm possible.
Stability	Very good values can be achieved using mechanical links.	High, since oil is almost incompressible, in addition, the pressure level is considerably higher than for pneumatics.	Low, air is compressible.
Forces	Not overloadable. Poor efficiency due to downstream mechanical elements. Very high forces can be realized.	Protected against overload, with high system pressure of up to 600 bar, very large forces can be generated $F < 3000$ kN.	Protected against overload, forces limited by pneumatic pressure and cylinder diameter $F < 30$ kN at 6 bar.



## **Chapter 2**

# **Fundamental physical principles of hydraulics**

## 2.1 Pressure

Hydraulics is the science of forces and movements transmitted by means of liquids. It belongs alongside hydro-mechanics. A distinction is made between hydrostatics – dynamic effect through pressure times area – and hydrodynamics – dynamic effect through mass times acceleration.

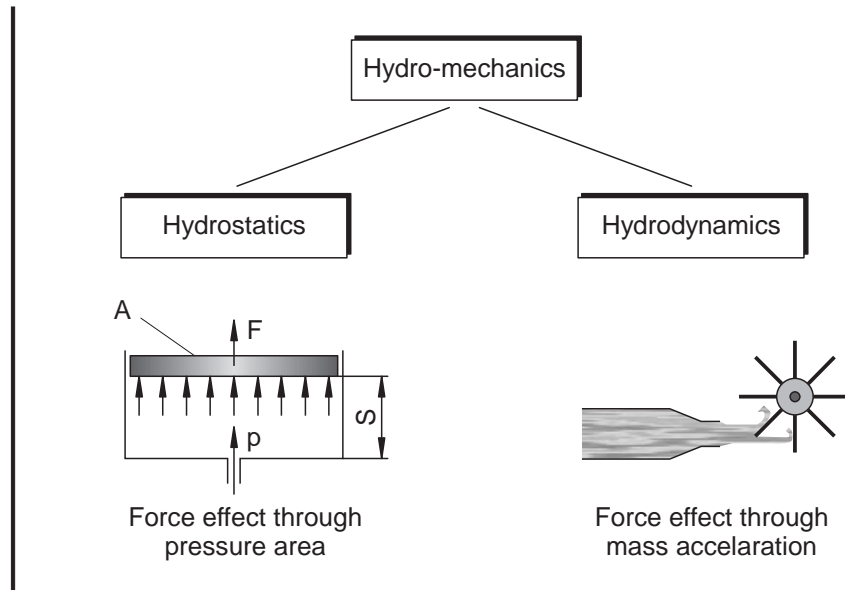

### Hydrostatic pressure

Hydrostatic pressure is the pressure which rises above a certain level in a liquid owing to the weight of the liquid mass:

$$p_s = h \cdot \rho \cdot g$$

$p_s$  = hydrostatic pressure (gravitational pressure) [Pa]

$h$  = level of the column of liquid [m]

$\rho$  = density of the liquid [ $\text{kg/m}^3$ ]

$g$  = acceleration due to gravity [ $\text{m/s}^2$ ]



In accordance with the SI international system of units, hydrostatic pressure is given in both Pascal and bar. The level of the column of liquid is given the unit “metre”, the density of the liquid “kilograms per cubic metre” and the acceleration due to gravity “metres per second squared”.

The hydrostatic pressure, or simply “pressure” as it is known for short, does not depend on the type of vessel used. It is purely dependent on the height and density of the column of liquid.

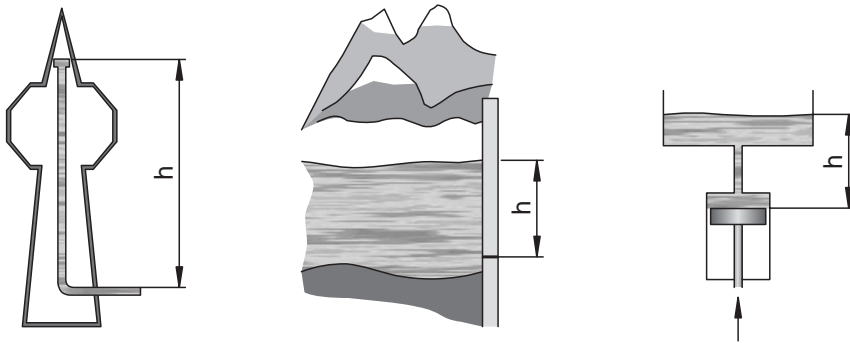

Hydrostatic pressure

### Column

$$h = 300 \text{ m}$$

$$\rho = 1000 \text{ kg/m}^3$$

$$g = 9.81 \text{ m/s}^2 \approx 10 \text{ m/s}^2$$

$$p_s = h \cdot \rho \cdot g$$

$$= 300 \text{ m} \cdot 1000 \text{ kg/m}^3 \cdot 10 \text{ m/s}^2$$

$$= 3000000 \frac{\text{m} \cdot \text{kg} \cdot \text{m}}{\text{m}^3 \cdot \text{s}^2}$$

$$= 3000000 \frac{\text{N}}{\text{m}^2}$$

$$\underline{p_s = 3\,000\,000 \text{ Pa (30 bar)}}$$

### Reservoir

$$h = 15 \text{ m}$$

$$\rho = 1000 \text{ kg/m}^3$$

$$g = 9.81 \text{ m/s}^2 \approx 10 \text{ m/s}^2$$

$$p_s = h \cdot \rho \cdot g$$

$$= 15 \text{ m} \cdot 1000 \text{ kg/m}^3 \cdot 10 \text{ m/s}^2$$

$$= 150000 \frac{\text{m} \cdot \text{kg} \cdot \text{m}}{\text{m}^3 \cdot \text{s}^2}$$

$$= 150000 \frac{\text{N}}{\text{m}^2}$$

$$\underline{p_s = 150\,000 \text{ Pa (1.5 bar)}}$$

**Elevated tank**

$$h = 5 \text{ m}$$

$$\rho = 1000 \text{ kg/m}^3$$

$$g = 9.81 \text{ m/s}^2 \approx 10 \text{ m/s}^2$$

$$p_s = h \cdot \rho \cdot g$$

$$= 5 \text{ m} \cdot 1000 \text{ kg/m}^3 \cdot 10 \text{ m/s}^2$$

$$= 50000 \frac{\text{m} \cdot \text{kg} \cdot \text{m}}{\text{m}^3 \cdot \text{s}^2}$$

$$= 50000 \frac{\text{N}}{\text{m}^2}$$

$$\underline{\underline{p_s = 50\,000 \quad (0.5 \text{ bar})}}$$

Every body exerts a specific pressure  $p$  on its base. The value of this pressure is dependent on the force due to weight  $F$  of the body and on the size of the area  $A$  on which the force due to weight acts.

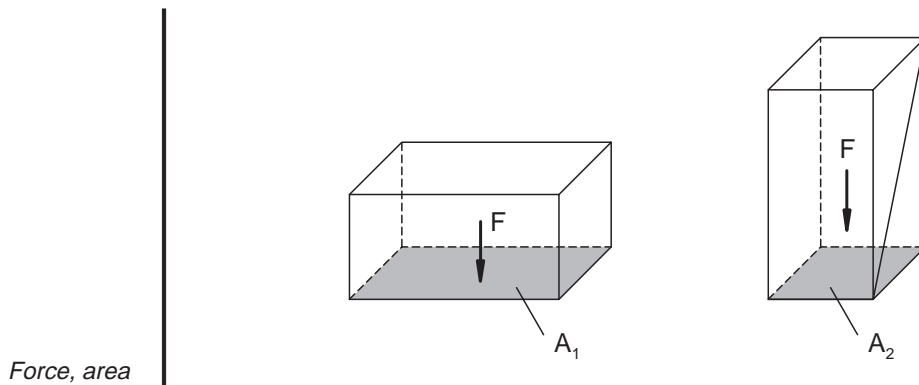

The diagram shows two bodies with different bases ( $A_1$  and  $A_2$ ). Where the bodies have identical mass, the same force due to weight ( $F$ ) acts on the base. However, the pressure is different owing to the different sizes of base. Where the force due to weight is identical, a higher pressure is produced in the case of a small base than in the case of a larger base (“pencil” or “concentrated” effect).

This is expressed by the following formula:

$$p = \frac{F}{A}$$

Unit:  $1 \text{ Pa} = 1 \frac{\text{N}}{\text{m}^2}$        $1 \text{ bar} = 100000 \frac{\text{N}}{\text{m}^2} = 10^5 \text{ Pa}$

$p$  = Pressure [Pa]

Pa = Pascal

$F$  = Force [N]

N = Newton ( $1 \text{ N} = 1 \frac{\text{kg} \cdot \text{m}}{\text{s}^2}$ )

$A$  = Area [m<sup>2</sup>]

m<sup>2</sup> = Square metre

Rearrangement of the formula produces the formulae for calculating force and area:

A cylinder is supplied with 100 bar pressure, its effective piston surface is equal to 7.85 cm<sup>2</sup>. Find the maximum force which can be attained.

Example

Given that:

$$p = 100 \text{ bar} = 1000 \text{ N/cm}^2$$

$$A = 7.85 \text{ cm}^2$$

$$F = p \cdot A$$

$$F = \frac{1000 \text{ N} \cdot 7.85 \text{ cm}^2}{\text{cm}^2}$$

$$\underline{\underline{F = 7850 \text{ N}}}$$

Example A lifting platform is to lift a load of 15 000 N and is to have a system pressure of 75 bar.  
How large does the piston surface A need to be?

Given that:

$$F = 15\,000\text{ N}$$

$$p = 75\text{ bar} = 75 \cdot 10^5\text{ Pa}$$

$$A = \frac{F}{p}$$

$$= \frac{15\,000\text{ N}}{75 \cdot 10^5\text{ Pa}}$$

$$= 0.002 \frac{\text{N} \cdot \text{m}^2}{\text{N}}$$

$$\underline{\underline{A = 0.002\text{ m}^2 = 20\text{ cm}^2}}$$

Instead of making calculations it is possible to work with a diagram. Example  
The friction in the cylinder is not taken into consideration.

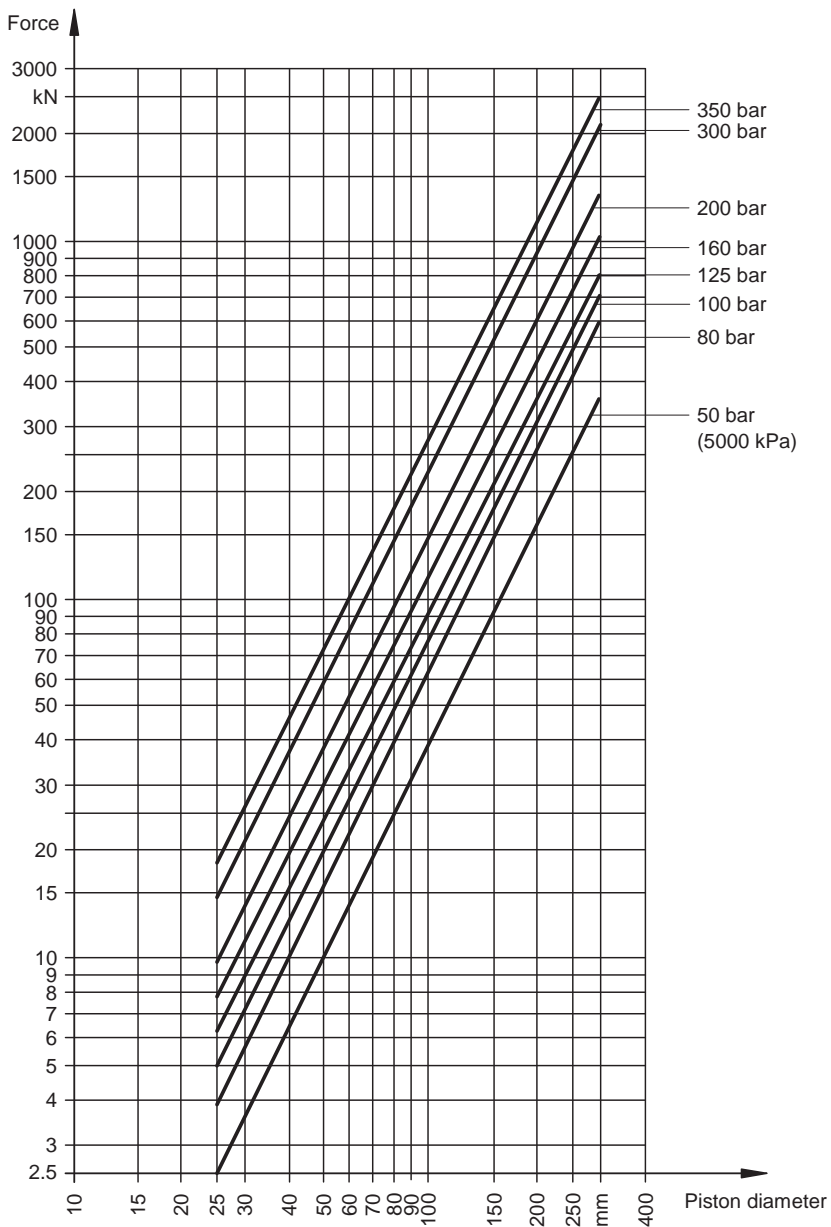

*Piston diameter, force and pressure*

Given that:

Force  $F = 100$  kN Operating pressure  $p = 350$  bar.

What is the piston diameter?

Reading:  $d = 60$  mm

## 2.2 Pressure transmission

If a force  $F_1$  acts via an area  $A_1$  on an enclosed liquid, a pressure  $p$  is produced which extends throughout the whole of the liquid (Pascal's Law). The same pressure applies at every point of the closed system (see diagram).

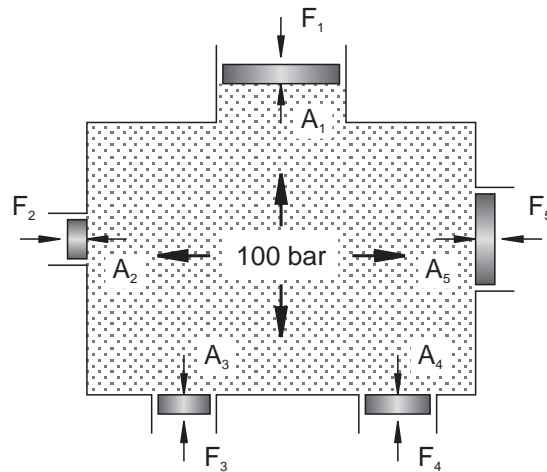

Pressure transmission

Owing to the fact that hydraulic systems operate at very high pressures, it is possible to neglect the hydrostatic pressure (see example). Thus, when calculating the pressure in liquids, the calculations are based purely on pressure caused by external forces. Thus, the same pressure acts on the surfaces  $A_2$ ,  $A_3$  as on  $A_1$ . For solid bodies, this is expressed by means of the following formula:

$$p = \frac{F}{A}$$

Given that:

$$A_1 = 10 \text{ cm}^2 = 0.001 \text{ m}^2$$

$$F = 10\,000 \text{ N}$$

$$p = \frac{F}{A}$$

$$= \frac{10\,000 \text{ N}}{0.001 \text{ m}^2} = 10\,000\,000 \frac{\text{N}}{\text{m}^2}$$

$$= \underline{\underline{100 \cdot 10^5 \text{ Pa (100 bar)}}}$$

Example

Given that:

$$p = 100 \cdot 10^5 \text{ Pa}$$

$$A_2 = 1 \text{ cm}^2 = 0.0001 \text{ m}^2$$

$$F = p \cdot A$$

$$= 100 \cdot 10^5 \text{ Pa} \cdot 0.0001 \text{ m}^2$$

$$= 1000 \frac{\text{N} \cdot \text{m}^2}{\text{m}^2}$$

$$\underline{\underline{F = 1000 \text{ N}}}$$

Example

### 2.3 Power transmission

The same pressure applies at every point in a closed system. For this reason, the shape of the container has no significance.

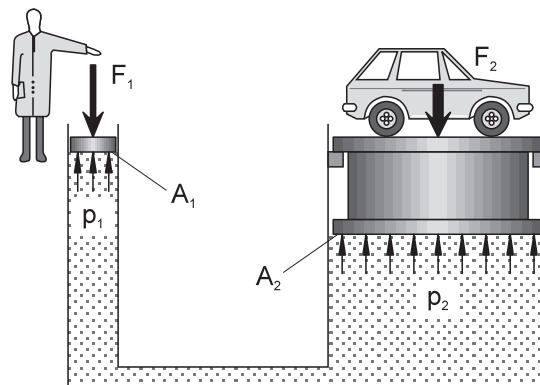

Power transmission

Where a container is formed as shown in the diagram, it is possible to transmit forces. The fluid pressure can be described by means of the following equations:

$$p_1 = \frac{F_1}{A_1} \quad \text{and} \quad p_2 = \frac{F_2}{A_2}$$

The following equation applies when the system is in equilibrium:

$$p_1 = p_2$$

When the two equations are balanced, the following formula is produced:

$$\frac{F_1}{A_1} = \frac{F_2}{A_2}$$

The values  $F_1$  and  $F_2$  and  $A_1$  and  $A_2$  can be calculated using this formula.



For example,  $F_1$  and  $A_2$  are calculated as shown here:

$$F_1 = \frac{A_1 \cdot F_2}{A_2} \quad \text{and} \quad A_2 = \frac{A_1 \cdot F_2}{F_1}$$

Small forces from the pressure piston can produce larger forces by enlarging the working piston surface. This is the fundamental principle which is applied in every hydraulic system from the jack to the lifting platform. The force  $F_1$  must be sufficient for the fluid pressure to overcome the load resistance (see example).

A vehicle is to be lifted by a hydraulic jack. The mass  $m$  amounts to 1500 kg.

Example

What force  $F_1$  is required at the piston?

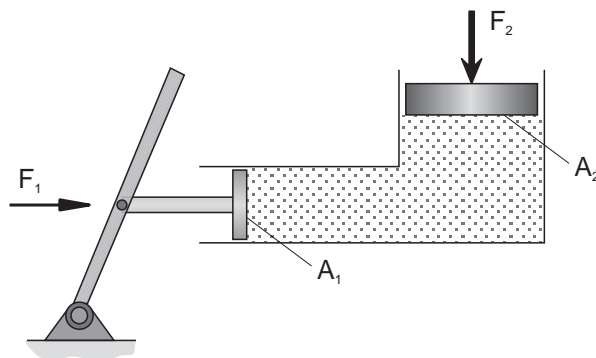

Power transmission

Given that:

Load  $m = 1500 \text{ kg}$

Force due to weight  $F_2 = m \cdot g$

$$F_2 = 1500 \text{ kg} \cdot 10 \frac{\text{m}}{\text{s}^2}$$

$$\underline{\underline{F_2 = 15\,000 \text{ N}}}$$

Given that:

$$A_1 = 40 \text{ cm}^2 = 0.004 \text{ m}^2$$

$$A_2 = 1200 \text{ cm}^2 = 0.12 \text{ m}^2$$

$$F_1 = \frac{A_1 \cdot F_2}{A_2}$$

$$= \frac{0.004 \text{ m}^2 \cdot 15000 \text{ N}}{0.12 \text{ m}^2}$$

$$\underline{\underline{F_1 = 500 \text{ N}}}$$

Example It has been proved that the force  $F_1$  of 100 N is too great for actuation by hand lever. What must the size of the piston surface  $A_2$  be when only a piston force of  $F_1 = 100 \text{ N}$  is available?

$$F_1 = \frac{A_1 \cdot F_2}{A_2}$$

$$A_2 = \frac{A_1 \cdot F_2}{F_1}$$

$$A_2 = \frac{0.004 \text{ m}^2 \cdot 15000 \text{ N}}{100 \text{ N}}$$

$$\underline{\underline{A_2 = 0.6 \text{ m}^2}}$$

If a load  $F_2$  is to be lifted a distance  $s_2$  in line with the principle described above, the piston  $P_1$  must displace a specific quantity of liquid which lifts the piston  $P_2$  by a distance  $s_2$ .

## 2.4 Displacement transmission

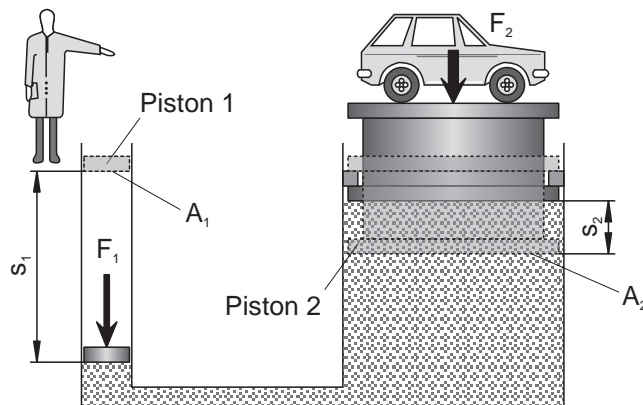

*Displacement transmission*

The necessary displacement volume is calculated as follows:

$$V_1 = s_1 \cdot A_1 \quad \text{and} \quad V_2 = s_2 \cdot A_2$$

Since the displacement volumes are identical ( $V_1 = V_2$ ), the following equation is valid:

$$s_1 \cdot A_1 = s_2 \cdot A_2$$

From this it can be seen that the distance  $s_1$  must be greater than the distance  $s_2$  since the area  $A_1$  is smaller than the area  $A_2$ .

The displacement of the piston is in inverse ratio to its area. This law can be used to calculate the values  $s_1$  and  $s_2$ . For example, for  $s_2$  and  $A_1$ .

$$s_2 = \frac{s_1 \cdot A_1}{A_2} \quad \text{and} \quad A_1 = \frac{s_2 \cdot A_2}{s_1}$$

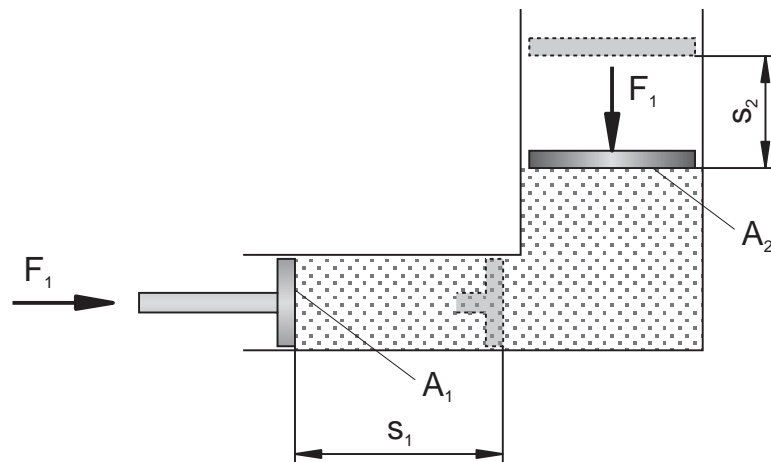

Displacement transmission  
– example

Given that:

$$\begin{aligned} A_1 &= 40 \text{ cm}^2 \\ A_2 &= 1200 \text{ cm}^2 \\ s_1 &= 15 \text{ cm} \end{aligned}$$

$$\begin{aligned} s_2 &= \frac{s_1 \cdot A_1}{A_2} \\ &= \frac{15 \cdot 40}{1200} \frac{\text{cm} \cdot \text{cm}^2}{\text{cm}^2} \end{aligned}$$

$$\underline{\underline{s_2 = 0.5 \text{ cm}}}$$

Given that:

$$\begin{aligned} A_2 &= 1200 \text{ cm}^2 \\ s_1 &= 30 \text{ cm} \\ s_2 &= 0.3 \text{ cm} \end{aligned}$$

$$\begin{aligned} A_1 &= \frac{s_2 \cdot A_2}{s_1} \\ &= \frac{0.3 \cdot 1200}{30} \frac{\text{cm} \cdot \text{cm}^2}{\text{cm}} \end{aligned}$$

$$\underline{\underline{A_1 = 12 \text{ cm}^2}}$$

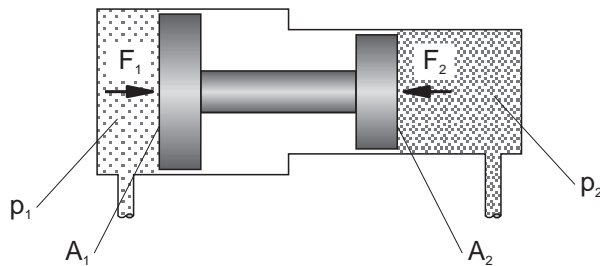

## 2.5 Pressure transfer

Pressure transfer

The hydrostatic pressure  $p_1$  exerts a force  $F_1$  on the area  $A_1$  which is transferred via the piston rod onto the small piston. Thus, the force  $F_1$  acts on the area  $A_2$  and produces the hydrostatic pressure  $p_2$ . Since piston area  $A_2$  is smaller than piston area  $A_1$ , the pressure  $p_2$  is greater than the pressure  $p_1$ . Here too, the following law applies:

$$p = \frac{F}{A}$$

From this, the following equations can be formulated for the forces  $F_1$  and  $F_2$ :

$$F_1 = p_1 \cdot A_1 \quad \text{and} \quad F_2 = p_2 \cdot A_2$$

Since the two forces are equal ( $F_1 = F_2$ ), the equations can be balanced:

$$p_1 \cdot A_1 = p_2 \cdot A_2$$

The values  $p_1$ ,  $A_1$  and  $A_2$  can be derived from this formula for calculations. For example, the following equations result for  $p_2$  and  $A_2$ :

$$p_2 = \frac{p_1 \cdot A_1}{A_2} \quad \text{and} \quad A_2 = \frac{p_1 \cdot A_1}{p_2}$$

In the case of the double-acting cylinder, excessively high pressures may be produced when the flow from the piston rod area is blocked:

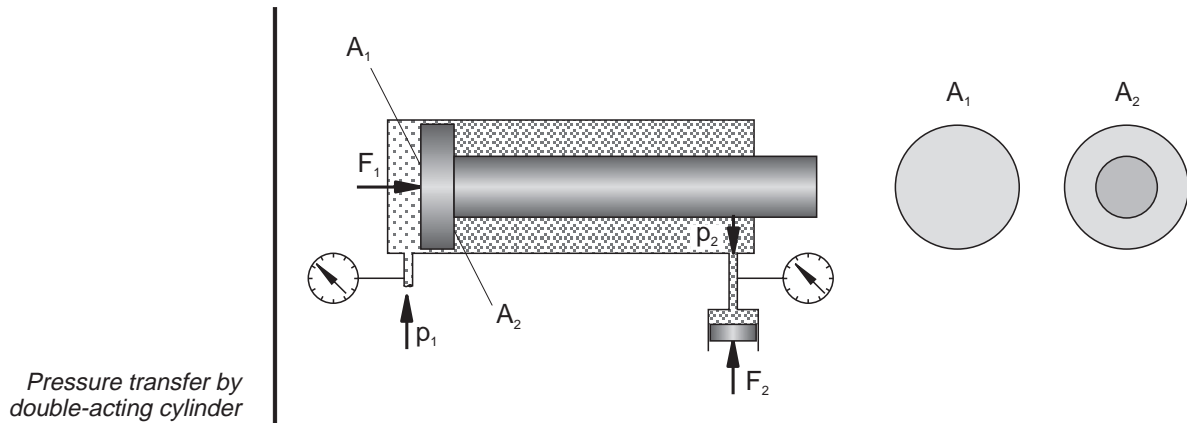

Given that:

$$p_1 = 10 \cdot 10^5 \text{ Pa}$$

$$A_1 = 8 \text{ cm}^2 = 0.0008 \text{ m}^2$$

$$A_2 = 4.2 \text{ cm}^2 = 0.00042 \text{ m}^2$$

$$\begin{aligned} p_2 &= \frac{p_1 \cdot A_1}{A_2} \\ &= \frac{10 \cdot 10^5 \cdot 0.0008}{0.00042} \frac{\text{N} \cdot \text{m}^2}{\text{m}^2 \cdot \text{m}^2} \end{aligned}$$

$$\underline{\underline{p_2 = 19 \cdot 10^5 \text{ Pa (19bar)}}}$$

Given that:

$$p_1 = 20 \cdot 10^5 \text{ Pa}$$

$$p_2 = 100 \cdot 10^5 \text{ Pa}$$

$$A_1 = 8 \text{ cm}^2 = 0.0008 \text{ m}^2$$

$$\begin{aligned} A_2 &= \frac{p_1 \cdot A_1}{p_2} \\ &= \frac{20 \cdot 10^5 \cdot 0.0008}{100 \cdot 10^5} \frac{\text{Pa} \cdot \text{m}^2}{\text{Pa}} \end{aligned}$$

$$\underline{\underline{A_2 = 0.00016 \text{ m}^2 = 16 \text{ cm}^2}}$$

Flow rate is the term used to describe the volume of liquid flowing through a pipe in a specific period of time. For example, approximately one minute is required to fill a 10 litre bucket from a tap. Thus, the flow rate amounts to 10 l/min.

## 2.6 Flow rate

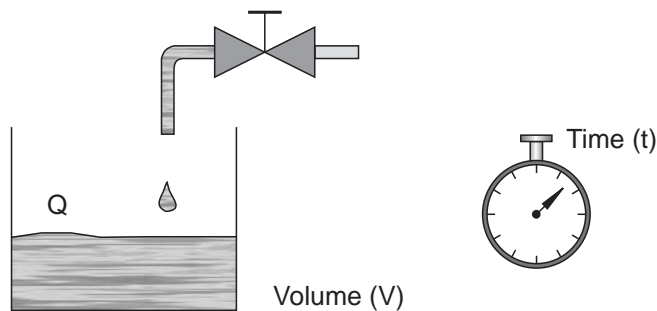

Flow rate

In hydraulics, the flow rate is designated as  $Q$ . The following equation applies:

$$Q = \frac{V}{t}$$

$Q$  = Flow rate [m<sup>3</sup>/s]

$V$  = volume [m<sup>3</sup>]

$t$  = time [s]

The equations for the volume ( $V$ ) and the time ( $t$ ) can be derived from the formula for the flow rate. The following equation is produced:

$$V = Q \cdot t$$

Example Given that:

$$Q = 4.2 \text{ l/min}$$

$$t = 10 \text{ s}$$

$$V = Q \cdot t$$

$$V = \frac{4.2 \cdot 10}{60} \frac{\text{l} \cdot \text{s} \cdot \text{min}}{\text{min} \cdot \text{s}}$$

$$\underline{V = 0.7 \text{ l}}$$

Result:

A flow rate of 4.2 litres per minute produces a volume of 0.7 litres in 10 seconds.

Example Given that:

$$V = 105 \text{ l}$$

$$Q = 4.2 \text{ l/min}$$

$$t = \frac{V}{Q}$$

$$t = \frac{105}{4.2} \frac{\text{l} \cdot \text{min}}{\text{l}}$$

$$\underline{t = 25 \text{ min}}$$

Result:

25 minutes are required to transport a volume of 105 litres at a flow rate of 4.2 litres per minute.



If the time  $t$  is replaced by  $s/v$  ( $v = s/t$ ) in the formula for the flow rate ( $Q = V/t$ ) and it is taken into account that the volume  $V$  can be replaced by  $A \cdot s$ , the following equation is produced:

$$Q = A \cdot v$$

$Q =$  flow rate  $[m^3/s]$

$v =$  flow velocity  $[m/s]$

$A =$  pipe cross-section  $[m^2]$

From the formula for the flow rate, it is possible to derive the formula for calculating the pipe cross-section and flow velocity. The following equation applies for  $A$  or  $v$ .

$$A = \frac{Q}{v}, \quad v = \frac{Q}{A}$$

Given that:

$$Q = 4.2 \text{ l/min} = \frac{4.2 \text{ dm}^3}{60 \text{ s}} = 0.07 \cdot 10^{-3} \frac{\text{m}^3}{\text{s}}$$

$$v = 4 \text{ m/s}$$

$$A = \frac{Q}{v}$$

$$A = \frac{0.07 \cdot 10^{-3}}{4} \frac{\text{m}^3 \cdot \text{s}}{\text{s} \cdot \text{m}}$$

$$\underline{\underline{A = 0.00002 \text{ m}^2 = 0.2 \text{ cm}^2}}$$

Result:

To achieve a flow velocity of 4 m/s with a flow rate of 4.2 l/min, a pipe cross-section of  $0.2 \text{ cm}^2$  is required.

## 2.7 Continuity equation

Example

Example Given that:

$$Q = 4.2 \text{ l/min} = 0.07 \cdot 10^{-3} \text{ m}^3/\text{s}$$

$$A = 0.28 \text{ cm}^2 = 0.28 \cdot 10^{-4} \text{ m}^2$$

$$v = \frac{Q}{A}$$

$$v = \frac{0.07 \cdot 10^{-3}}{0.28 \cdot 10^{-4}} \frac{\text{m}^3}{\text{s} \cdot \text{m}^2}$$

$$v = \frac{0.7}{0.28} \cdot 10^1 \frac{\text{m}}{\text{s}}$$

$$\underline{v = 2.5 \text{ m/s}}$$

Result:

In a pipe with a cross-section of  $0.28 \text{ cm}^2$ , a flow rate of  $4.2 \text{ l/min}$  brings about a flow velocity of  $2.5 \text{ m/s}$ .

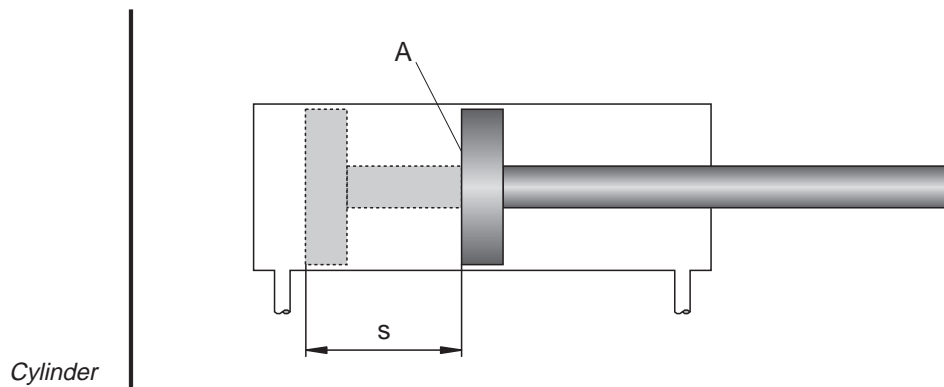

If in the formula for the flow rate

$$Q = \frac{V}{t}$$

the volume replaced by the displacement volume  $V$

$$V = A \cdot s$$

results in

$$Q = \frac{A \cdot s}{t}$$

Given that:

$$A = 8 \text{ cm}^2$$

$$s = 10 \text{ cm}$$

$$t = 1 \text{ min}$$

$$Q = \frac{A \cdot s}{t}$$

$$= \frac{8 \cdot 10}{1} \frac{\text{cm}^2 \cdot \text{cm}}{\text{min}}$$

$$\underline{Q = 80 \text{ cm}^3/\text{min} = 0.08 \text{ dm}^3/\text{min}}$$

Example

Result:

If a cylinder with a piston surface of  $8 \text{ cm}^2$  and a stroke of  $10 \text{ cm}$  is to extend in one minute, the power supply must generate a flow rate of  $0.08 \text{ l/min}$ .

The flow rate of a liquid in terms of volume per unit of time which flows through a pipe with several changes in cross-section is the same at all points in the pipe (see diagram). This means that the liquid flows through small cross-sections faster than through large cross-sections. The following equation applies:

$Q_1 = A_1 \cdot v_1$	$Q_2 = A_2 \cdot v_2$	$Q_3 = A_3 \cdot v_3$	etc. . .
-----------------------	-----------------------	-----------------------	----------

As within one line the value for Q is always the same, the following equation of continuity applies:

$A_1 \cdot v_1 = A_2 \cdot v_2 = A_3 \cdot v_3 = \dots$
---

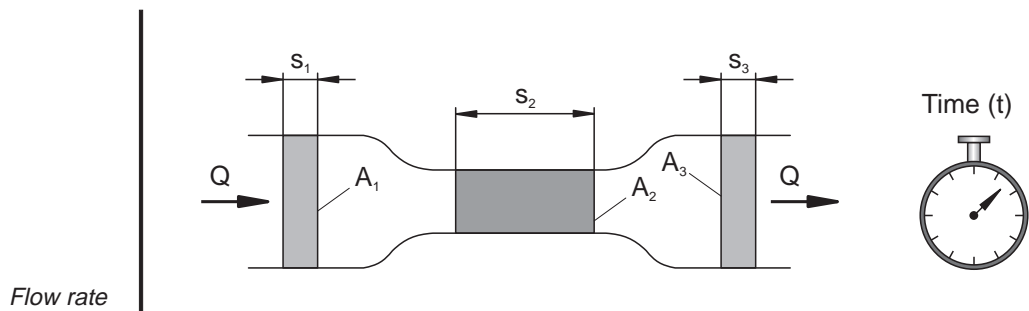

Example Given that:

$$v_1 = 4 \text{ m/s}$$

$$v_2 = 100 \text{ m/s}$$

$$A_1 = 0.2 \text{ cm}^2 = 0.2 \cdot 10^{-4} \text{ m}^2$$

$$A_2 = 0.008 \text{ cm}^2 = 0.008 \cdot 10^{-4} \text{ m}^2$$

$$Q = A \cdot v$$

$$Q_1 = 0.2 \cdot 10^{-4} \text{ m}^2 \cdot 4 \text{ m/s}$$

$$Q_2 = 0.008 \cdot 10^{-4} \text{ m}^2 \cdot 100 \text{ m/s}$$

$$Q = \underline{\underline{0.8 \cdot 10^{-4} \text{ m}^3/\text{s}}}$$

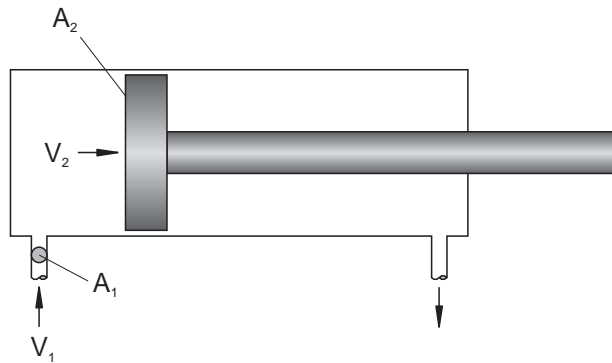

Cylinder

Given that:

Example

Pump delivery Q

$$Q = 10 \frac{\text{l}}{\text{min}} = 10 \frac{\text{dm}^3}{\text{min}}$$

$$Q = 10 \cdot 10^3 \frac{\text{cm}^3}{\text{min}}$$

$$Q = \frac{10 \cdot 10^3}{60} \frac{\text{cm}^3}{\text{s}}$$

Inlet internal diameter  $d_1 = 6 \text{ mm}$

Piston diameter  $d_2 = 32 \text{ mm}$

To be found:

- Flow velocity  $v_1$  in the inlet pipe
- Extension speed  $v_2$  of the piston

$$Q = v_1 \cdot A_1 = v_2 \cdot A_2$$

$$A_1 = \frac{d^2 \cdot \pi}{4} = \frac{0.6^2 \cdot \text{cm}^2 \cdot \pi}{4} = 0.28 \text{ cm}^2$$

$$A_2 = \frac{d^2 \cdot \pi}{4} = \frac{3.2^2 \cdot \text{cm}^2 \cdot \pi}{4} = 8.0 \text{ cm}^2$$

$$v_1 = \frac{Q}{A_1}$$

$$= \frac{10 \cdot 10^3 \text{ cm}^3}{60 \text{ s}} = \frac{10 \cdot 10^3}{60 \cdot 0.28} \frac{\text{cm}^3}{\text{cm}^2 \cdot \text{s}}$$

$$\underline{\underline{v_1 = 595 \frac{\text{cm}}{\text{s}} = 5.95 \frac{\text{m}}{\text{s}}}}$$

$$v_2 = \frac{Q}{A_2}$$

$$= \frac{10 \cdot 10^3 \text{ cm}^3}{60 \text{ s}} = \frac{10 \cdot 10^3}{60 \cdot 8} \frac{\text{cm}^3}{\text{cm}^2 \cdot \text{s}}$$

$$\underline{\underline{v_2 = 20.8 \frac{\text{cm}}{\text{s}} = 0.21 \frac{\text{m}}{\text{s}}}}$$

To measure pressures in the lines or at the inputs and outputs of components, a pressure gauge is installed in the line at the appropriate point.

**2.8 Pressure measurement**

A distinction is made between absolute pressure measurement where the zero point on the scale corresponds to absolute vacuum and relative pressure measurement where the zero point on the scale refers to atmospheric pressure. In the absolute system of measurement, vacuums assume values lower than 1, in the relative system of measurement, they assume values lower than 0.

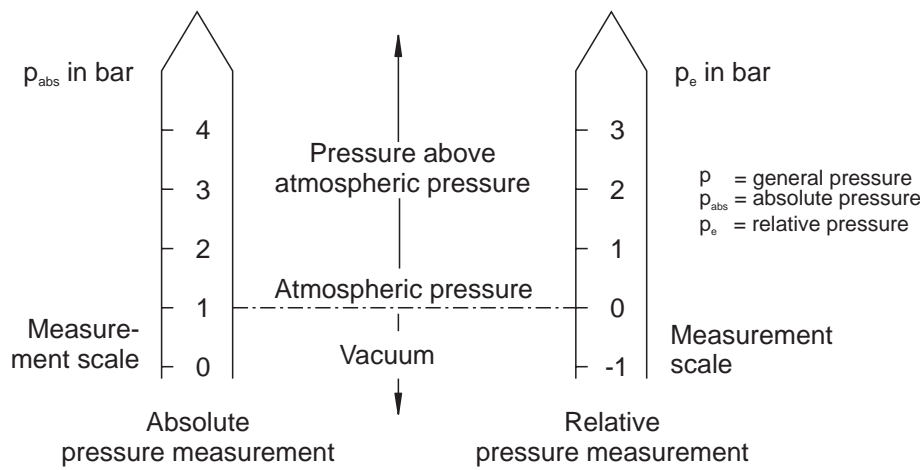

*Absolute pressure, relative pressure*

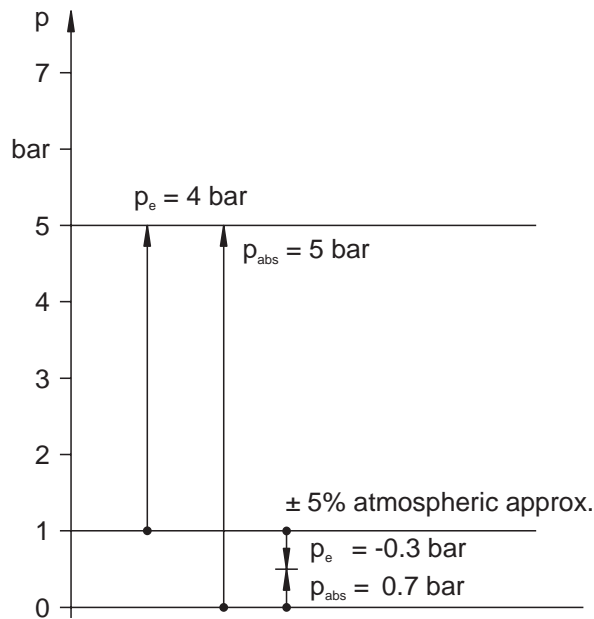

*Example*

### 2.9 Temperature measurement

The temperature of hydraulic fluid in hydraulic installations can either be measured using simple **measuring devices** (thermometers) or else by means of a **measuring device** which sends signals to the control section. Temperature measurement is of special significance since high temperatures ( > 60 degrees) lead to premature ageing of the hydraulic fluid. In addition, the viscosity changes in accordance with the temperature.

The **measuring devices** may be installed in the hydraulic fluid reservoir. To keep the temperature constant, a **pilotherm** or **thermostat** is used which switches the cooling or heating system on as required.

### 2.10 Measurement of flow rate

The simplest method of measuring flow rate is with a **measuring container** and a **stop watch**.

However, **turbine meters** are recommended for continuous measurements. The speed indicated provides information about the value of the flow rate. Speed and flow rate behave proportionally.

Another alternative is to use an **orifice**. The fall in pressure recorded at the orifice is an indication of the flow rate (pressure drop and flow rate behave proportionally), measurement by orifice is scarcely influenced by the viscosity of the hydraulic fluid.



A distinction is made between laminar and turbulent flow.

## 2.11 Types of flow

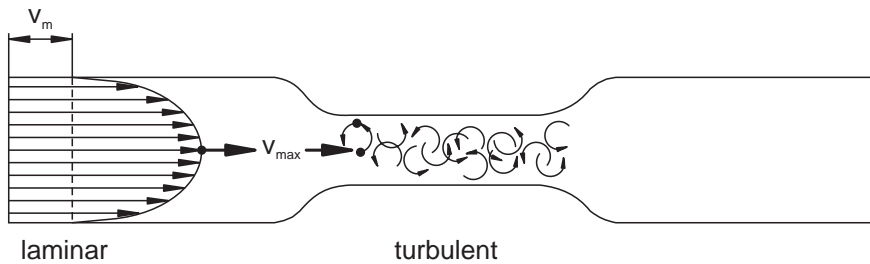

*Laminar and turbulent flow*

In the case of laminar flow, the hydraulic fluid moves through the pipe in ordered cylindrical layers. The inner layers of liquid move at higher speeds than the outer layers. If the flow velocity of the hydraulic fluid rises above a certain point (known as the critical speed), the fluid particles cease to move in ordered layers. The fluid particles at the centre of the pipe swing out to the side. As a result, the fluid particles affect and hinder one another, causing an eddy to be formed; flow becomes turbulent. As a consequence of this, power is withdrawn from the main flow.

A method of calculating the type of flow in a smooth pipe is enabled by the Reynolds' number (Re). This is dependent on

- the flow velocity of the liquid  $v$  (m/s)
- the pipe diameter  $d$  (m)
- and the kinetic viscosity  $\nu$  ( $\text{m}^2/\text{s}$ )

$$\text{Re} = \frac{v \cdot d}{\nu}$$

The physical variable “kinematic viscosity” is also referred to simply as “viscosity”.

A value for Re calculated with this formula can be interpreted as follows:

laminar flow:  $Re < 2300$

turbulent flow:  $Re > 2300$

The value 2300 is termed the critical Reynolds' number ( $Re_{crit}$ ) for smooth round pipes.

Turbulent flow does not immediately become laminar on falling below ( $Re_{crit}$ ). The laminar range is not reached until  $1/2 (Re_{crit})$ .

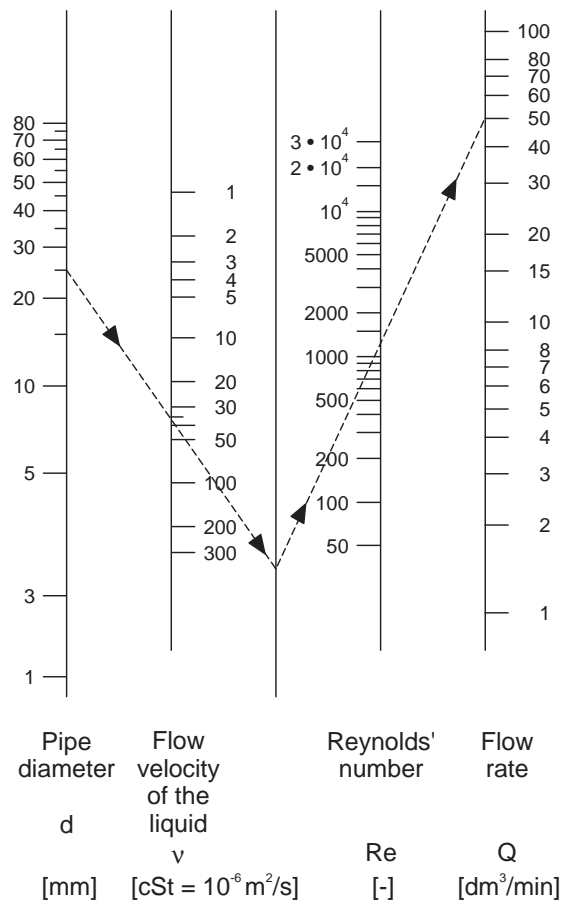

Determining of the Reynolds' number (Prof. Charchut)

$$\begin{aligned} Q &= 50 \text{ dm}^3/\text{min} \\ d &= 25 \text{ mm} \\ \nu &= 36 \text{ cSt} \end{aligned}$$

$$\text{Re} = 1165$$

### Example

The critical velocity mentioned above is the velocity at which the flow changes from laminar to turbulent.

$$V_{\text{krit}} = \frac{\text{Re}_{\text{crit}} \cdot \nu}{d} = \frac{2300 \nu}{d}$$

To prevent turbulent flow causing considerable friction losses in hydraulic systems, ( $\text{Re}_{\text{crit}}$ ) should not be exceeded.

The critical speed is not a fixed value since it is dependent on the viscosity of the hydraulic fluid and the diameter of the pipe. Therefore, empirically determined values are generally used in practice. The following standard values for  $v_{\text{crit}}$  are valid for the flow velocity in lines.

- Pressure line:
  - to 50 bar operating pressure: 4.0 m/s
  - to 100 bar operating pressure: 4.5 m/s
  - to 150 bar operating pressure: 5.0 m/s
  - to 200 bar operating pressure: 5.5 m/s
  - to 300 bar operating pressure: 6.0 m/s
- Suction line: 1.5 m/s
- Return line: 2.0 m/s

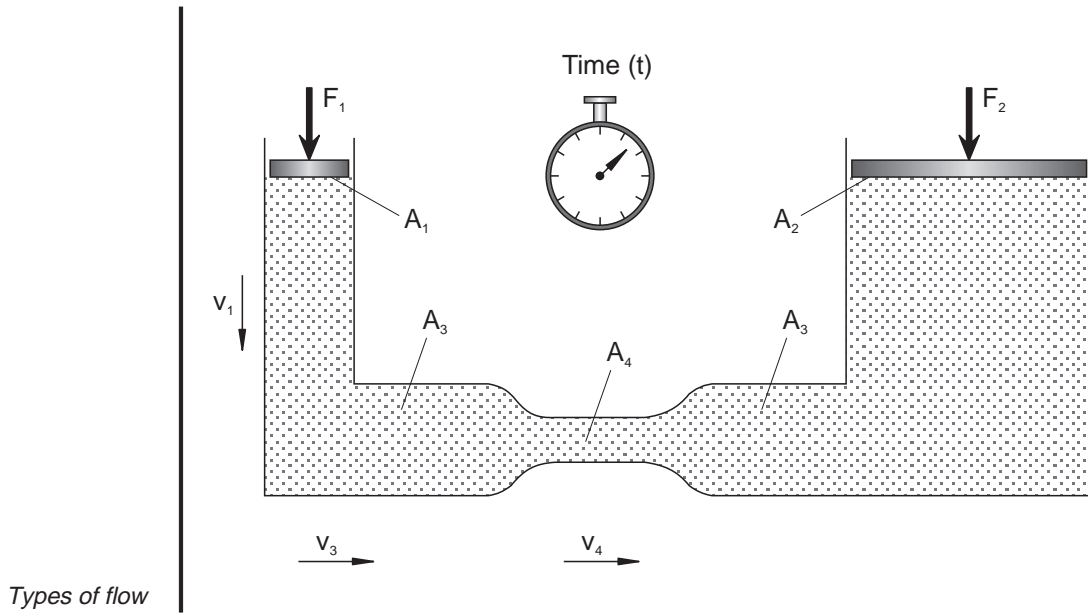

Example Given that:

$$v_1 = 1 \text{ m/s}$$

$$v_3 = 4 \text{ m/s}$$

$$v_4 = 100 \text{ m/s}$$

$$\nu = 40 \text{ mm}^2/\text{s}$$

$$d_1 = 10 \text{ mm}$$

$$d_3 = 5 \text{ mm}$$

$$d_4 = 1 \text{ mm}$$

The type of flow at cross-sections  $A_1$ ,  $A_3$ ,  $A_4$  is to be found.

$$\text{Re} = \frac{v \cdot d_1}{\nu}$$

$$\text{Re}_1 = \frac{1000\text{mm} \cdot 10\text{mm} \cdot \text{s}}{\text{s} \cdot 40\text{mm}^2} = 250$$

$$\text{Re}_3 = \frac{4000\text{mm} \cdot 5\text{mm} \cdot \text{s}}{\text{s} \cdot 40\text{mm}^2} = 500$$

$$\text{Re}_4 = \frac{100\,000\text{mm} \cdot 1\text{mm} \cdot \text{s}}{\text{s} \cdot 40\text{mm}^2} = 2500$$

Result:

The flow is only turbulent at cross-section A4 since  $2500 > 2300$ . The flow becomes laminar again at cross-section A3 after the throttling point as  $500 < 1150$ . However, this is only after a steadying period.

**Friction** occurs in all devices and lines in a hydraulic system through which liquid passes.

## 2.12 Friction, heat, pressure drop

This friction is mainly at the line walls (external friction). There is also friction between the layers of liquid (internal friction).

The friction causes the hydraulic fluid, and consequently also the components, to be heated. As a result of this heat generation, the pressure in the system drops and, thus, reduces the actual pressure at the drive section.

The size of the pressure drop is based on the internal resistances in a hydraulic system. These are dependent on:

- Flow velocity (cross-sectional area, flow rate),
- Type of flow (laminar, turbulent),
- Type and number of cross-sectional reductions in the system of lines (throttles, orifices),
- Viscosity of the oil (temperature, pressure),
- Line length and flow diversion,
- Surface finish,
- Line arrangement.

The flow velocity has the greatest effect on the internal resistances since the resistance rises in proportion to the square of the velocity.

*Influence of flow velocity  
on pressure loss*

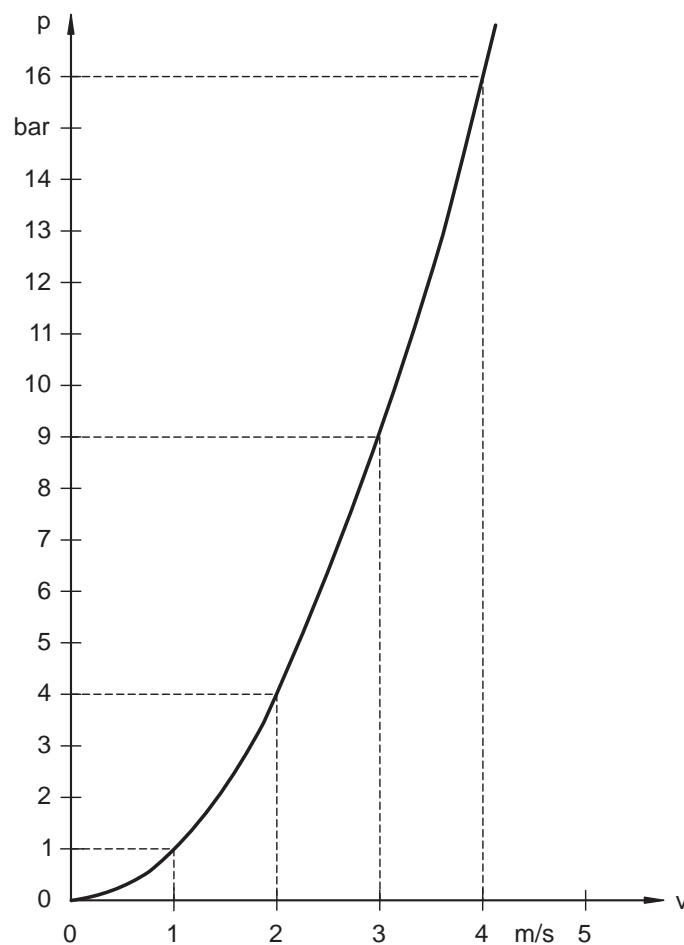

The friction between the flowing layers of liquid and the adhesion of the liquid to the pipe wall form a resistance which can be measured or calculated as a drop in pressure. Flow resistance in pipelines

Since the flow velocity has an influence on the resistance to the power of two, the standard values should not be exceeded.

Flow resistance in pipelines per 1 m length											
For hydraulic fluid with $\rho = 850 \text{ kg/m}^3$ (K) at approx. 15 °C ( $\nu = 100 \text{ mm}^2/\text{s}$ ); (W) at approx. 60 °C ( $\nu = 20 \text{ mm}^2/\text{s}$ )											
v (m/s)		0.5		1		2		4		6	
d (mm)		K	W	K	W	K	W	K	W	K	W
6	Re	30	150	60	300	120	600	240	1200	360	1800
	$\lambda$	2.5	0.5	2.25	0.25	0.625	0.125	0.312	0.0625	0.21	0.04
	$\Delta p$ bar/m	0.44	0.09	0.88	0.177	1.77	0.35	3.54	0.70	5.3	1.02
10	Re	50	250	100	500	200	1000	400	2000	600	3000
	$\lambda$	1.5	0.3	0.75	0.15	0.375	0.075	0.187	0.037	0.125	0.043
	$\Delta p$ bar/m	0.16	0.03	0.32	0.064	0.64	0.13	1.27	0.25	1.9	0.65
20	Re	100	500	200	1000	400	2000	800	4000	1200	6000
	$\lambda$	0.75	0.15	0.375	0.075	0.187	0.037	0.093	0.04	0.062	0.036
	$\Delta p$ bar/m	0.04	0.008	0.08	0.016	0.16	0.03	0.32	0.136	0.47	0.275
30	Re	150	750	300	1500	600	3000	1200	6000	1800	9000
	$\lambda$	0.5	0.1	0.25	0.05	0.125	0.043	0.062	0.036	0.042	0.032
	$\Delta p$ bar/m	0.017	0.003	0.035	0.007	0.07	0.024	0.14	0.082	0.214	0.163

Flow resistance in pipelines per 1 m length (2)											
For hydraulic fluid with $\rho = 850 \text{ kg/m}^3$ (K) at approx. 15 °C ( $\nu = 100 \text{ mm}^2/\text{s}$ ); (W) at approx. 60 °C ( $\nu = 20 \text{ mm}^2/\text{s}$ )											
v (m/s)		0.5		1		2		4		6	
d (mm)		K	W	K	W	K	W	K	W	K	W
40	Re	200	1000	400	2000	800	4000	1600	8000	2400	12000
	$\lambda$	0.375	0.075	0.187	0.037	0.093	0.04	0.047	0.033	0.045	0.03
	$\Delta p$ bar/m	0.01	0.002	0.02	0.004	0.04	0.017	0.08	0.056	0.172	0.114
50	Re	250	1250	500	2500	1000	5000	2000	10000	3000	15000
	$\lambda$	0.3	0.06	0.15	0.045	0.075	0.037	0.037	0.031	0.043	0.028
	$\Delta p$ bar/m	0.006	0.001	0.013	0.004	0.025	0.012	0.05	0.042	0.13	0.085
60	Re	300	1500	600	3000	1200	6000	2400	12000	3600	18000
	$\lambda$	0.25	0.05	0.125	0.043	0.062	0.036	0.045	0.03	0.04	0.027
	$\Delta p$ bar/m	0.004	0.0008	0.009	0.003	0.017	0.01	0.05	0.034	0.1	0.007



A flow with a velocity of  $v = 0.5$  m/s flows through a pipeline with a nominal width of 6 mm.

The kinematic viscosity amounts to  $\nu = 100$  mm<sup>2</sup>/s at 15 °C.

The density  $\rho = 850$  kg/m<sup>3</sup>.

Calculate the pressure loss  $\Delta p$  for 1 m length.

Example for calculating the values in the table

$$\Delta p = \lambda \cdot \frac{l}{d} \cdot \frac{\rho}{2} \cdot v^2$$

Figure for resistance of pipes  $\lambda = \frac{75}{Re}$  (resistance value)

In order to calculate the friction value  $\lambda$ , it is first necessary to calculate the Reynolds' number  $Re$ :

$$Re = \frac{v \cdot d}{\nu}$$

Given that:

$$\nu = 100 \text{ mm}^2/\text{s} = 1 \cdot 10^{-4} \text{ m}^2/\text{s}$$

$$d = 6 \text{ mm} = 0.006 \text{ m}$$

$$v = 0.5 \text{ m/s}$$

$$Re = \frac{0.5 \cdot 0.006}{1 \cdot 10^{-4}}$$

$$\underline{Re = 30 \text{ (comp. with table)}}$$

Figure for resistance of pipes  $\lambda = \frac{75}{Re}$

$$\lambda = \frac{75}{30}$$

$$\underline{\lambda = 2.5 \text{ (comp. with table)}}$$

$$\Delta p = \lambda \cdot \frac{l}{d} \cdot \frac{\rho}{2} \cdot v^2$$

$$\Delta p = 2.5 \cdot \frac{1000\text{mm}}{6\text{mm}} \cdot \frac{850\text{kg}}{2\text{m}^3} \cdot (0.5\text{m/s})^2 \quad 1 \frac{\text{kg} \cdot \text{m}}{\text{s}^2} = 1\text{N}$$

$$\Delta p = 44270 \frac{\text{kg} \cdot \text{m}}{\text{m}^2 \cdot \text{s}^2} \quad 1 \frac{\text{kg} \cdot \text{m}}{\text{m}^2 \cdot \text{s}^2} = 1\text{N/m}^2$$

$$\Delta p = 44270 \text{ N/m}^2 \quad 10^5 \text{ bar} = 1 \text{ bar}$$

$$\underline{\underline{\Delta p = 0.4427 \text{ bar (comp. with table)}}$$

Pressure losses through formed parts

Flow reversal causes a considerable drop in pressure in curved pipes, T-pieces, branches and angle connections. The resistances which arise are chiefly dependent on the geometry of the formed parts and the flow value.

These pressure losses are calculated using the form coefficient  $\zeta$  for which the most common shapes are set as a result of experimental tests.

$$\Delta p = \xi \cdot \frac{\rho \cdot v^2}{2}$$

Since the form coefficient is heavily dependent on the Reynolds' number, a correction factor  $b$  corresponding to the Re number is taken into consideration. Thus, the following applies for the laminar range:

$$\Delta p = \xi \cdot b \cdot \frac{\rho \cdot v^2}{2}$$

Table for correction factor  $b$

Re	25	50	100	250	500	1000	1500	2300
b	30	15	7.5	3	1.5	1.25	1.15	1.0

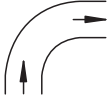
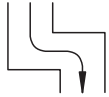
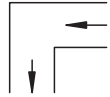
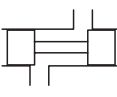
					
T-piece	90° bend	Double angle	90° angle	Valve	
$\xi$	1.3	0.5 - 1	2	1.2	5 ... 15

*Table for the form coefficient*

Calculate the pressure drop  $\Delta p$  in an elbow with the nominal size 10 mm. Example

Given that:

Flow speed  $v = 5 \text{ m/s}$

Density of the oil  $\rho = 850 \text{ kg/m}^3$

Viscosity  $\nu = 100 \text{ mm}^2/\text{s}$  at  $150 \text{ }^\circ\text{C}$ .

First Re is calculated:  $\text{Re} = \frac{v \cdot d}{\nu}$

$$\text{Re} = \frac{5 \text{ m} \cdot 0.01 \text{ m} \cdot \text{s}}{\text{s} \cdot 0.0001 \text{ m}^2}$$

$$\underline{\underline{\text{Re} = 500}}$$

Factor from the table  $b = 1.5$

Form coefficient from the table  $\zeta = 1.2$

$$\Delta p = \xi \cdot b \cdot \frac{\rho \cdot v^2}{2}$$

$$\Delta p = 1.2 \cdot 1.5 \cdot \frac{850 \text{ kg} \cdot 25 \text{ m}^2}{\text{m}^3 \cdot \text{s}^2 \cdot 2}$$

$$\Delta p = 19125 \text{ N/m}^2$$

$$\underline{\underline{\Delta p = 0.19 \text{ bar}}}$$

The pressure loss in the valves can be derived from the  $\Delta p$ -Q-characteristics of the manufacturer.

Pressure losses in the valves

## 2.13 Energy and power

The energy content of a hydraulic system is made up of several forms of energy. As stated in the law of conservation of energy, the total energy of a flowing liquid is constant. It only changes when energy in the form of work is externally supplied or carried away. The total energy is the sum of the various forms of energy:

- Potential energy static
- Pressure energy static
  
- Motion energy dynamic
- Thermal energy dynamic

### Potential energy

Potential energy is the energy which a body (or a liquid) has when it is lifted by a height  $h$ . Here, work is carried out against the force of gravity. In presses with large cylinders, this potential energy is used for fast filling of the piston area and for pilot pressure for the pump. The amount of energy stored is calculated on the basis of an example.

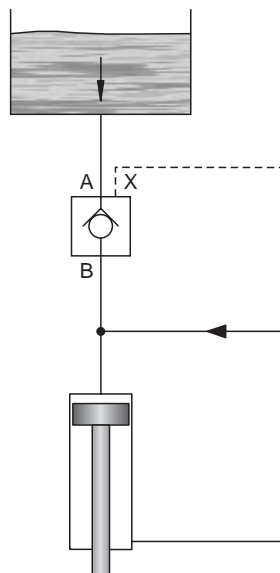

Diagram – press with elevated reservoir

$$W = m \cdot g \cdot h$$

W = Work [J]

m = mass of the liquid (kg)

g = acceleration due to gravity [ $\text{m/s}^2$ ]

h = height of the liquid [m]

from:  $W = F \cdot s$        $F = m \cdot g$

is produced:  $W = m \cdot g \cdot h$        $s = h$

unit:  $1 \text{ kg} \cdot \text{m/s}^2 \cdot \text{m} = 1 \text{ Nm} = 1 \text{ J} = 1 \text{ W/s}$

$1 \text{ J} = 1 \text{ Joule},$        $1 \text{ W} = 1 \text{ Watt}$

Given that:

m = 100 kg

g =  $9.81 \text{ m/s}^2 \approx 10 \text{ m/s}^2$

h = 2 m

$$W = m \cdot g \cdot h$$

$$W = 100 \text{ kg} \cdot 10 \text{ m/s}^2 \cdot 2 \text{ m}$$

$$W = 2000 \frac{\text{kg} \cdot \text{m} \cdot \text{m}}{\text{s}^2}$$

$$W = 2000 \text{ Nm}$$

$$\underline{\underline{W = 2000 \text{ J}}}$$

**Pressure energy** If a liquid is pressurized, its volume is reduced, the amount by which it is reduced being dependent on the gases released. The compressible area amounts to 1-3 % of the output volume. Owing to the limited compressibility of the hydraulic fluid, i.e. the relatively small  $\Delta V$ , the pressure energy is low. At a pressure of 100 bar  $\Delta V$  amounts to approx. 1 % of the output volume. A calculation based on these values is shown overleaf.

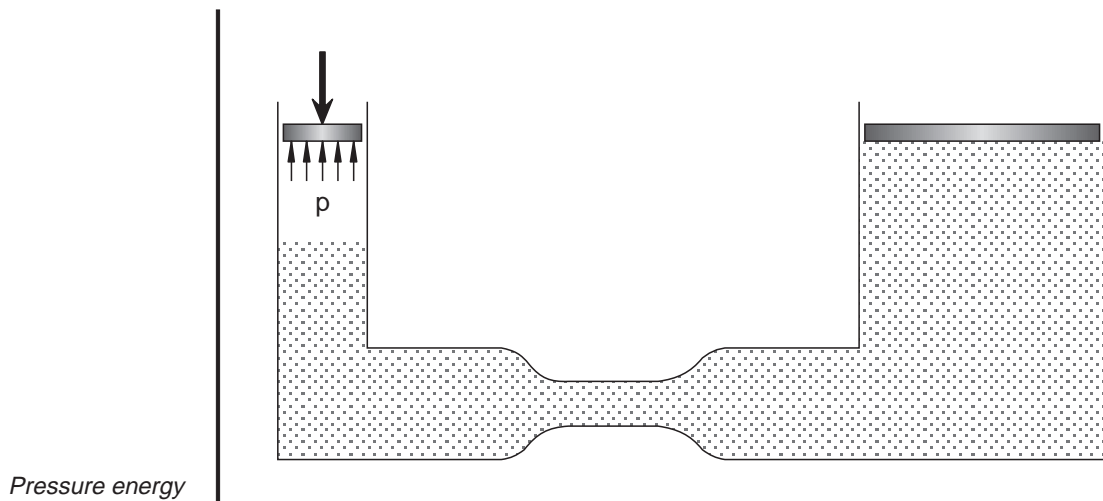

$$W = p \cdot \Delta V$$

$p$  = Liquid pressure [Pa]

$\Delta V$  = Liquid volume [ $m^3$ ]

from  $W = F \cdot s$  and  $F = p \cdot A$  is produced:

$$W = p \cdot A \cdot s$$

$A \cdot s$  is replaced by  $\Delta V$ , producing:

$$W = p \cdot \Delta V$$

Unit:  $1 \text{ N/m}^2 \cdot m^3 = 1 \text{ Nm} = 1 \text{ J}$

Given that:

$$p = 100 \cdot 10^5 \text{ Pa}$$

$$\Delta V = 0.001 \text{ m}^3$$

$$W = p \cdot \Delta V$$

$$= 100 \cdot 10^5 \text{ Pa} \cdot 0.001 \text{ m}^3$$

$$= 0.1 \cdot 10^5 \frac{\text{N} \cdot \text{m}^3}{\text{m}^2}$$

$$\underline{\underline{W = 10\,000 \text{ J}}}$$

Example

Pressure energy is obtained from the resistance with which the fluid volume meets the compression.

All matter is compressible, i.e., if the initial pressure  $p_0$  is increased by the value  $\Delta p$ , the initial volume  $V_0$  is reduced by the value  $\Delta V$ . This compressibility is increased even further by the gases dissolved in the oil (to 9%) and by the rising temperature.

In the case of precision drives, the compressibility of the oil must not be neglected. The characteristic value for this is the compression modulus  $K$  which is also often referred to as the modulus of elasticity for oil =  $E_{\text{oil}}$ . This modulus can be calculated in the usual pressure range using the following approximate formula.

$$K \approx V_0 \cdot \frac{\Delta p}{\Delta V} \quad [\text{N/m}^2 \text{ oder N/cm}^2]$$

$V_0$  = output volume,  $\Delta V$  = volume reduction.

The value  $K$  represents air-free oil at  $50 \text{ }^\circ\text{C} \approx 1.56 \cdot 10^5 \text{ N/cm}^2$ . Since the oil generally contains air, the  $K$  value of  $1.0$  bis  $1.2 \cdot 10^5 \text{ N/cm}^2$  is used in practice.

Example 200 bar counter pressure is applied to the oil volume for a cylinder with a diameter of 100 mm and a length of 400 mm ( $l_0$ ). By how many mm is the piston rod pushed back?

Compression modulus

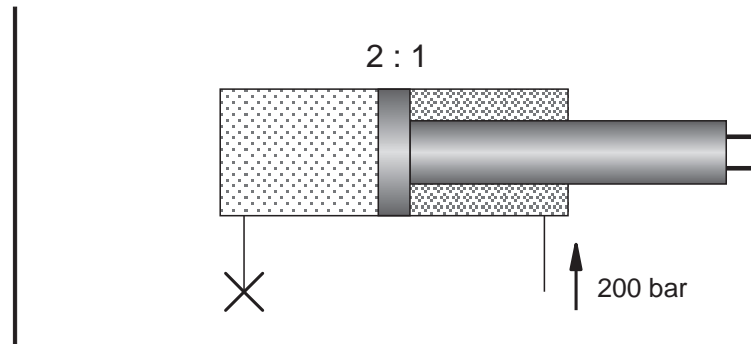

The area ratio piston side to piston rod side amounts to 2:1 and the compression modulus  $K = 1.2 \cdot 10^5 \text{ N/cm}^2$  (the elasticity of the material and the expansion of the cylinder barrel are not taken into consideration).

Solution: The area ratio 2:1 produces an additional 100 bar of pressure on the constrained oil volume. From

$$K = V_0 \cdot \frac{\Delta p}{\Delta V}$$

is produced:

$$\Delta V = V_0 \cdot \frac{\Delta p}{K}$$

$$\Delta V = A \cdot \Delta l$$

$$V_0 = A \cdot l_0$$

$$A \cdot \Delta l = A \cdot l_0 \cdot \frac{\Delta p}{K}$$

$$\Delta l = l_0 \cdot \frac{\Delta p}{K}$$

$$\Delta l = 400 \text{ mm} \cdot \frac{1000 \text{ N/cm}^2}{1.2 \cdot 10^5 \text{ N/cm}^2}$$

$$\underline{\underline{\Delta l = 3.33 \text{ mm}}}$$



Therefore, the piston rod is pushed back by 3.33 mm. For this calculation, the increase in volume caused by changes in temperature was not taken into consideration. This is because the changes in pressure are generally so fast that an adiabatic change in status (i. e. one proceeding without heat exchange) may be assumed.

This example shows that compressibility can be neglected in many cases (e. g. in presses). However, it is advisable to keep pipe lines and cylinders as short as possible.

Thus, instead of long cylinders, spindle drives or similar devices which are driven by hydraulic motors are used for linear movements on machine tools.

Motion energy (also known as kinetic energy) is the energy a body (or fluid particle) has when it moves at a certain speed. The energy is supplied through acceleration work, a force  $F$  acting on the body (or fluid particle).

Motion energy

The motion energy is dependent on the flow velocity and the mass.

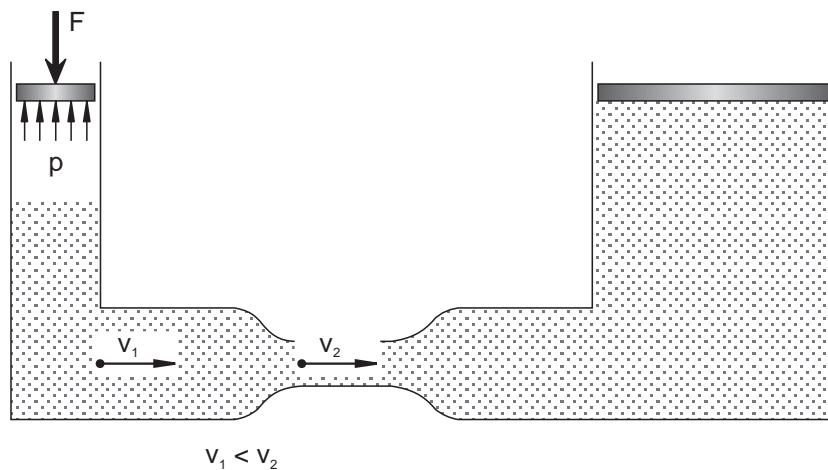

Motion energy

$$W = \frac{1}{2} m \cdot v^2$$

v velocity [m/s]

a acceleration [m/s<sup>2</sup>]

$$W = F \cdot s$$

$$F = m \cdot a$$

$$W = m \cdot a \cdot s$$

$$s = \frac{1}{2} a \cdot t^2$$

$$W = m \cdot a \cdot \frac{1}{2} a \cdot t^2$$

$$v = a \cdot t$$

$$W = \frac{1}{2} m \cdot a^2 \cdot t^2$$

$$W = \frac{1}{2} m \cdot v^2$$

$$\text{Unit: } 1 \text{ kg} \cdot (\text{ms})^2 = 1 \text{ kg} \cdot \text{m}^2/\text{s}^2 = 1 \text{ Nm} = 1 \text{ J}$$

Example Given that:

$$m = 100 \text{ kg}$$

$$v_1 = 4 \text{ m/s}$$

$$W = \frac{1}{2} m \cdot v^2$$

$$= \frac{1}{2} \cdot 100 \text{ kg} \cdot (4 \text{ m/s})^2$$

$$= 800 \frac{\text{kg} \cdot \text{m}^2}{\text{s}^2}$$

$$\underline{\underline{W = 800 \text{ J}}}$$

$$v_2 = 100 \text{ m/s}$$

$$\begin{aligned} W &= \frac{1}{2} m \cdot v^2 \\ &= \frac{1}{2} \cdot 100 \text{ kg} \cdot (100 \text{ m/s})^2 \\ &= 500000 \frac{\text{kg} \cdot \text{m}^2}{\text{s}^2} \end{aligned}$$

$$\underline{\underline{W = 500\,000 \text{ J}}}$$

Every change in the flow velocity (in the case of a constant flow rate) automatically results in a change in the motion energy. Its share of the total energy increases when the hydraulic fluid flows faster and decreases when the speed of the hydraulic fluid is reduced.

Owing to varying sizes of line cross-section, the hydraulic fluid flows in a hydraulic system at various speeds as shown in the diagram since the flow rate, the product of the flow velocity and the cross-section are constant.

**Thermal energy** Thermal energy is the energy required to heat a body (or a liquid) to a specific temperature.

In hydraulic installations, part of the energy is converted into thermal energy as a result of friction. This leads to heating of the hydraulic fluid and of the components. Part of the heat is emitted from the system, i.e. the remaining energy is reduced. The consequence of this is a decrease in pressure energy.

The thermal energy can be calculated from the pressure drop and the volume.

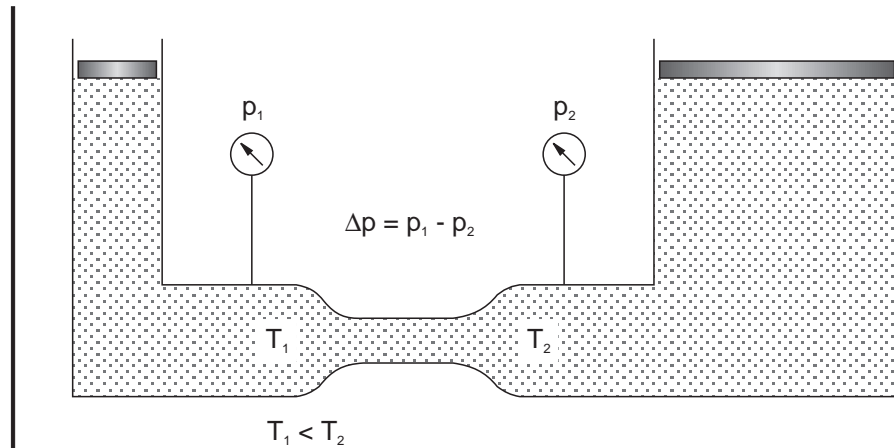

Thermal energy

$$W = \Delta p \cdot V \quad \Delta p = \text{Pressure loss through friction [Pa]}$$

$$\text{Unit: } 1 \text{ Pa} \cdot \text{m}^3 = 1 \text{ N} \frac{\text{m}^3}{\text{m}^2} = 1 \text{ Nm} = 1 \text{ J}$$

**Example** Given that:

$$\Delta p = 5 \cdot 10^5 \text{ Pa}$$

$$V = 0.1 \text{ m}^3$$

$$\begin{aligned} W &= p \cdot V \\ &= 5 \cdot 10^5 \text{ Pa} \cdot 0.1 \text{ m}^3 \\ &= 0.5 \cdot 10^5 \frac{\text{N}}{\text{m}^2} \text{ m}^3 \end{aligned}$$

$$\underline{\underline{W = 50\,000 \text{ J}}}$$

Power is usually defined as work or a change in energy per unit of time. In hydraulic installations, a distinction is made between mechanical and hydraulic power. Mechanical power is converted into hydraulic power, transported, controlled and then converted back to mechanical power.

Hydraulic power is calculated from the pressure and the flow rate.

The following equation applies:

$$P = p \cdot Q$$

$P$  = Power (W) = (Nm/s)

$p$  = Pressure (Pa)

$Q$  = Flow rate (m<sup>3</sup>/s)

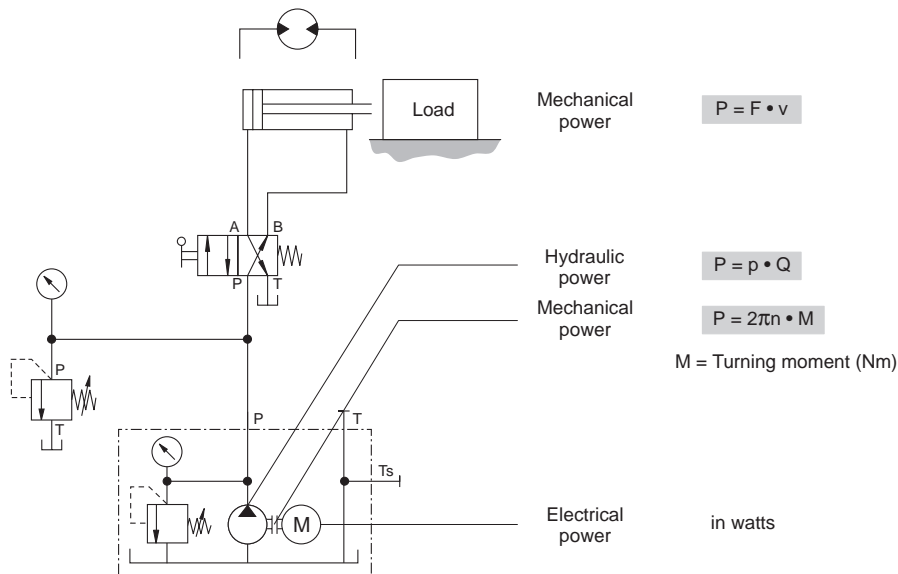

Power

Example Given that:

$$p = 60 \cdot 10^5 \text{ Pa}$$

$$Q = 4.2 \text{ l/min} = 4.2 \cdot 10^{-3} \text{ m}^3/\text{min}$$

$$= \frac{4.2}{60} 10^{-3} \text{ m}^3 / \text{s} = 0.07 \cdot 10^{-3} \text{ m}^3 / \text{s}$$

$$P = p \cdot Q$$

$$= 60 \cdot 10^5 \text{ Pa} \cdot 0.07 \cdot 10^{-3} \text{ m}^3/\text{s}$$

$$= 4.2 \cdot 10^2 \frac{\text{Nm}^3}{\text{m}^2\text{s}}$$

$$\underline{\underline{P = 420 \text{ W}}}$$

The following applies if the equation is changed around to express the pressure:

$p = \frac{P}{Q}$
-------------------

Example Given that:

$$P = 315 \text{ W}$$

$$Q = 4.2 \text{ l/min} = \frac{4.2}{60} \text{ dm}^3 / \text{s} = 0.07 \cdot 10^{-3} \text{ m}^3 / \text{s}$$

$$p = \frac{315}{0.07 \cdot 10^{-3}} \frac{\text{Nm} \cdot \text{s}}{\text{s} \cdot \text{m}^3}$$

$$= 4500 \cdot 10^3 \text{ N/m}^2 \text{ (Pa)}$$

$$\underline{\underline{p = 45 \cdot 10^5 \text{ Pa (45 bar)}}}$$

$$Q = \frac{P}{p}$$

Given that:

$$P = 150 \text{ W}$$

$$p = 45 \cdot 10^5 \text{ Pa}$$

$$Q = \frac{150 \text{ W}}{45 \cdot 10^5 \text{ Pa}}$$

$$= 3.3 \cdot 10^{-5} \frac{\text{Nm} \cdot \text{m}^2}{\text{s} \cdot \text{N}}$$

$$= 3.3 \cdot 10^{-5} \text{ m}^3/\text{s} = 0.033 \text{ dm}^3/\text{s}$$

$$\underline{\underline{Q = 2 \text{ l/min}}}$$

Example

The input power in a hydraulic system does not correspond to the output power since line losses occur. The ratio of the output power to the input power is designated as efficiency ( $\eta$ ).

Efficiency

$$\text{Efficiency} = \frac{\text{output power}}{\text{input power}}$$

In practice, distinction is made between volumetric power loss caused by leakage losses and hydro-mechanical power loss caused by friction.

In the same way, efficiency is divided into:

- **Volumetric efficiency ( $\eta_{\text{vol}}$ ):**  
This covers the losses resulting from internal and external leakage losses in the pumps, motors, and valves.
- **Hydro-mechanical efficiency ( $\eta_{\text{hm}}$ ):**  
This covers the losses resulting from friction in pumps, motors, and cylinders.

The total losses occurring in pumps, motors, and cylinders during power conversion are given as the total efficiency ( $\eta_{tot}$ ) and calculated as follows:

$$\eta_{ges} = \eta_{vol} \cdot \eta_{hm}$$

The following example illustrates how the different types of efficiency need to be taken into consideration when calculating the input and output power in a hydraulic system. The values given are experimental values which need to be replaced by manufacturers' values for practical application.

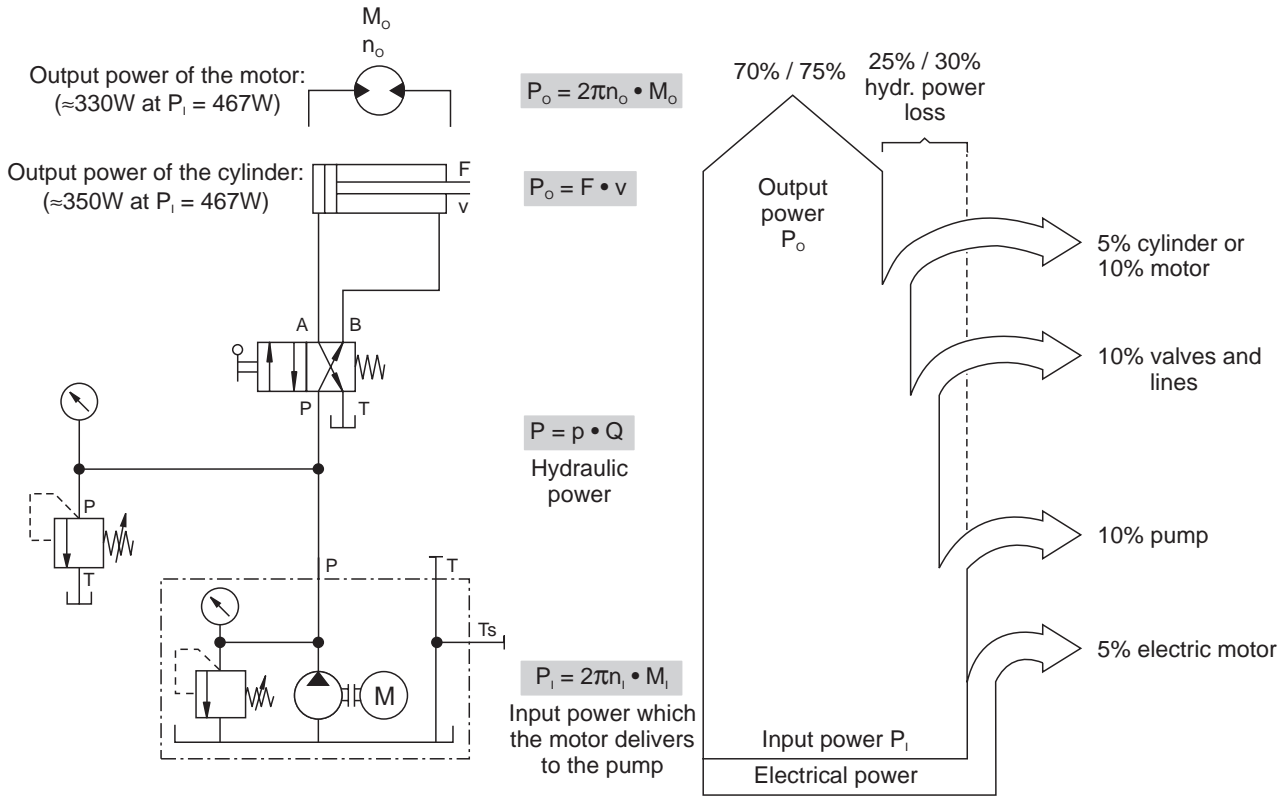

Calculation of input and output power



Cavitation (Lat. cavitare = to hollow out) refers to the releasing of the smallest particles from the surface of the material. Cavitation occurs on the control edges of hydraulic devices (pumps and valves). This eroding of the material is caused by local pressure peaks and high temperatures.

Flash temperatures are sudden, high increases in temperature.

What causes the pressure drop and the flash temperatures?

Motion energy is required for an increase in flow velocity of the oil at a narrowing. This motion energy is derived from the pressure energy. Because of this, pressure drops at narrow points may move into the vacuum range. From a vacuum of  $p_e \leq -0.3$  bar onwards, dissolved air is precipitated. Gas bubbles are formed.

If the pressure now rises again as a result of a reduction in speed, the oil causes the gas bubbles to collapse.

## 2.14 Cavitation

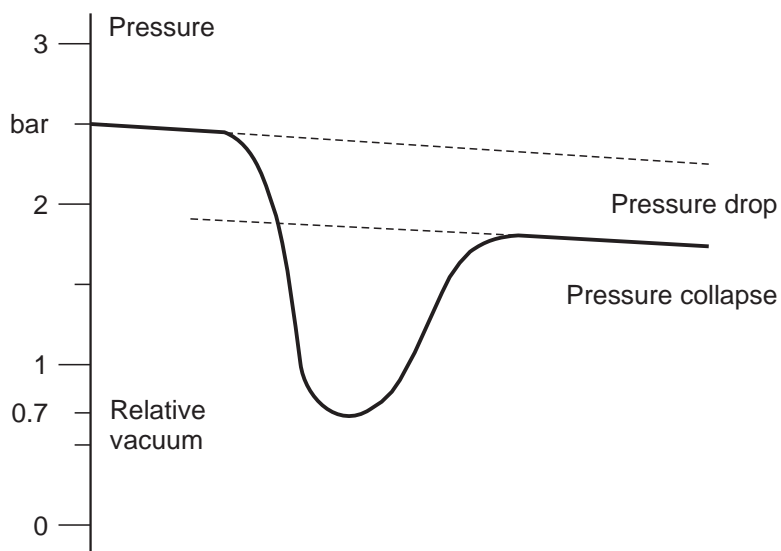

*Pressure drop  
at the narrow point*

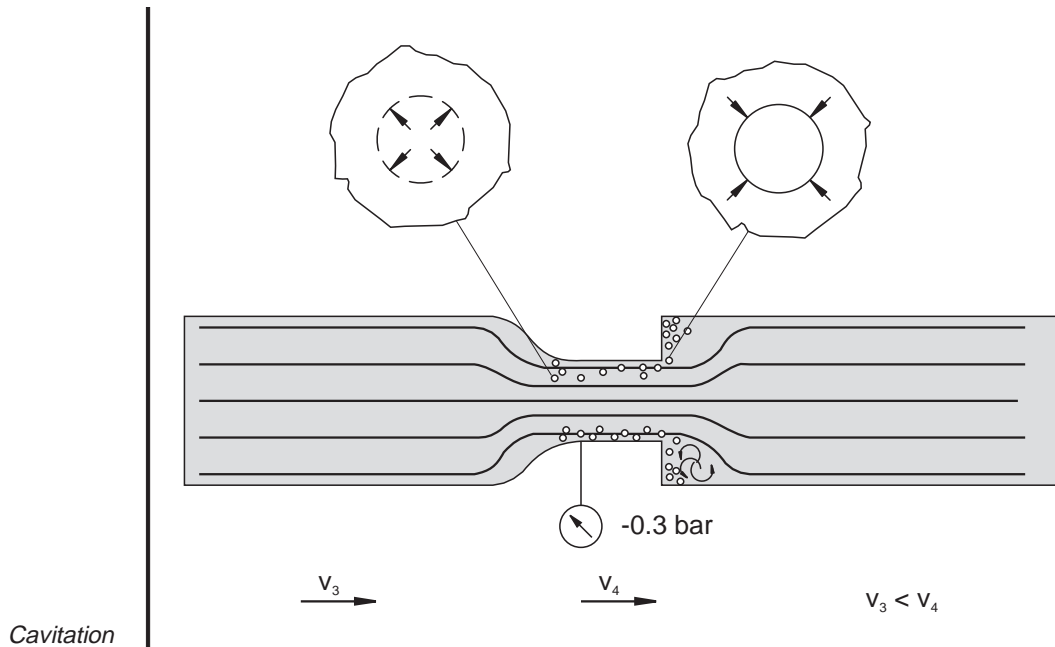

After the narrowing, the pressure rises again, the bubbles burst and the following cavitation effects might occur:

- **Pressure peaks**

Small particles are eroded from the pipe wall at the point where the cross-section is enlarged. This leads to material fatigue and often to fractures. This cavitation effect is accompanied by considerable noise.

- **Spontaneous ignition of the oil/air mixture**

When the air bubbles burst, the oil displaces the bubbles. Owing to the high pressure after the narrowing, very high temperatures are produced as a result of compression of the air on the bubbles bursting. As with a diesel engine, this may lead to spontaneous ignition of the oil/air mixture in the bubbles (diesel effect).

There are various explanations for the presence of air in a hydraulic system:

Liquids always contain a certain quantity of air. Under normal atmospheric conditions, hydraulic oils contain approx. 9 % air vol. in soluble form. However, this proportion varies according to the pressure, temperature, and type of oil. Air can also get into the hydraulic system from outside, particularly at leaky throttle points.

In addition, it is possible that hydraulic oil taken in by the pump already contains air bubbles. This may be caused by the return line running incorrectly into the oil reservoir, by the hydraulic oil being kept in the oil reservoir for too short a time, or by insufficient air releasing properties in the hydraulic oil.

The subjects covered in this chapter – types of flow, friction, heat, pressure drop, energy, power, and cavitation – are all illustrated by examples based on a throttle point:

## 2.15 Throttle points

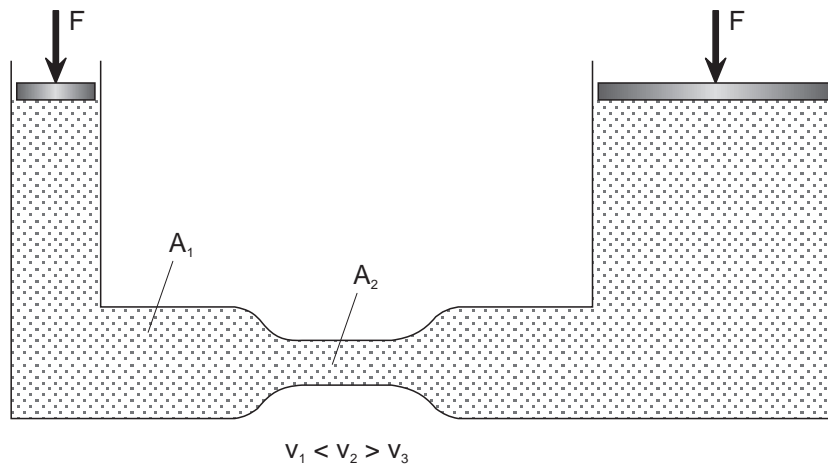

Throttle point

At throttle points, the value of the Reynolds' figure is far above 2300. The reason for this is the cross-sectional narrowing which, owing to the constant flow rate, results in an increase in flow velocity. Thus, the critical speed at which the flow changes from laminar to turbulent is achieved very quickly.

The Law of Conservation of Energy states that the total energy in a system always remains constant. Therefore, if the motion energy increases as a result of a higher flow velocity, one of the other types of energy must be reduced. Energy conversion takes place from pressure energy into motion energy and thermal energy. The increase in the flow velocity causes the friction to rise; this leads to heating of the hydraulic fluid and an increase in thermal energy. Part of the heat is emitted from the system. Consequently, the flow rate after the throttle point has the same flow velocity as before the throttle point. However, the pressure energy has been reduced by the amount of the thermal energy resulting in a fall in pressure after the throttle point.

The decrease in energy at throttle points leads to power losses. These can be determined by measuring the pressure loss and the increase in temperature. Pressure losses are dependent on:

- viscosity
- flow velocity
- type and length of throttle
- type of flow (laminar, turbulent).

Poiseuille's formula

$$Q = \alpha \cdot A_D \cdot \sqrt{\frac{2 \cdot \Delta p}{\rho}}$$

$\alpha$  = Flow reference number

$A_D$  = Throttle cross-section [m<sup>2</sup>]

$\Delta p$  = Pressure drop [Pa]

$\rho$  = Density of the oil [kg/m<sup>3</sup>]

can be expressed more simply by leaving out the constants:

$$Q \sim \sqrt{\Delta p}$$

Flow through a throttle is dependent on the pressure difference.

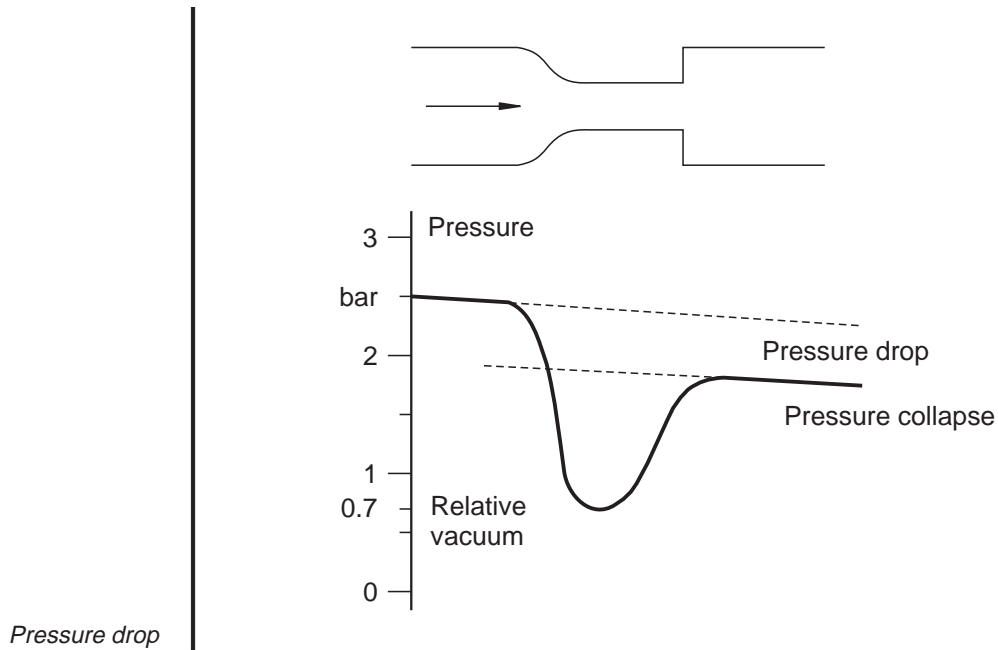

If the pressure at the throttle point drops into the vacuum range, the air exits from the oil and bubbles are formed which are filled with oil gas and air (cavitation).

If the pressure increases again after the throttle point at the transition to the enlarged cross-section, the bubbles burst. This leads to cavitation effects – eroding of the material in the area of the cross-sectional enlargement and, potentially, to spontaneous ignition of the hydraulic oil.

# Chapter 3

## Hydraulic fluid

In principle, any liquid can be used to transfer pressure energy. However, as in hydraulic installations, other characteristics are also required of hydraulic fluids, the number of suitable fluids is considerably restricted. As a hydraulic fluid, water causes problems related to corrosion, boiling point, freezing point and low viscosity.

Hydraulic fluids with a mineral oil base – also known as **hydraulic oils** – fulfil most normal requirements (e.g. for machine tools). They are used very widely.

Hydraulic fluids with low inflammability are required for hydraulic systems with high risk of fire such as, for example:

- hard coal mining
- die-casting machines
- forging presses
- control units for power station turbines
- and steel works and rolling mills.

In all these applications, there is a risk that hydraulic fluids based on mineral oils will catch fire on intensively heated metal parts. Oil mixtures containing water or synthetic oils are used here in place of standard oils.

### 3.1 Tasks for hydraulic fluids

The hydraulic fluids used in hydraulic installations must fulfil very varied tasks:

- pressure transfer,
- lubrication of the moving parts of devices,
- cooling, i. e. diversion of the heat produced by energy conversion (pressure losses),
- cushioning of oscillations caused by pressure jerks,
- corrosion protection,
- scuff removal,
- signal transmission.



Within these two groups – hydraulic oils and hydraulic fluids with low inflammability – there are various types of fluid with different characteristics. These characteristics are determined by a basic fluid and small quantities of additives.

### 3.2 Types of hydraulic fluid

#### Hydraulic oils

In DIN 51524 and 51525 hydraulic oils are divided according to their characteristics and composition into three classes:

- Hydraulic oil HL
- Hydraulic oil HLP
- Hydraulic oil HV.

The designations for these oils are composed of the letter H for hydraulic oil and an additional letter for the additives. The code letter is supplemented by a **viscosity code** defined in DIN 51517 (ISO viscosity classes).

Designation	Special characteristics	Areas of application
HL	Increased corrosion protection and ageing stability	Systems in which high thermal demands are made or corrosion through immersion in water is possible.
HLP	Increased wearing protection	Like HL oil, also for use in systems where variable high friction occurs owing to design or operating factors.
HV	Improved viscosity-temperature characteristics	Like HLP oil, for use in widely fluctuating and low ambient temperatures.

*Hydraulic oil for hydraulic systems*

HLP 68	<p>H: hydraulic oil</p> <p>L: with additives to increase corrosion protection and/or ageing stability</p> <p>P: with additives to reduce and/or increase load carrying ability</p> <p>68: Viscosity code as defined in DIN 51517</p>
--------	--

*Hydraulic oil HLP 68*

Hydraulic fluids with low inflammability

Where these hydraulic fluids are concerned, a distinction is made between **hydrous and anhydrous** synthetic hydraulic fluids. The synthetic hydraulic fluids are chemically composed so that their vapour is not flammable.

The table shown here provides an overview of hydraulic fluids with low flammability (HF liquids). They are also described in VDMA standard sheets 24317 and 24320.

Abbreviated code	VDMA standard sheet no.	Composition	Water content in %
HFA	24 320	Oil-water emulsions	80 ... 98
HFB	24 317	Water-oil emulsions	40
HFC	24 317	Hydrous solutions, e.g. water-glycol	35...55
HFD	24 317	Anhydrous liquid, e.g. phosphate ether	0...0,1

*Hydraulic fluids with low flammability*

For hydraulic oils to be able to fulfil the requirements listed above, they must exhibit certain qualities under the relevant operating conditions. Some of these **qualities** are listed here:

- lowest possible density;
- minimal compressibility;
- viscosity not too low (lubricating film);
- good viscosity-temperature characteristics;
- good viscosity-pressure characteristics;
- good ageing stability;
- low flammability;
- good material compatibility;

In addition, hydraulic oils should fulfil the following requirements:

- air release;
- non-frothing;
- resistance to cold;
- wear and corrosion protection;
- water separable.

The most important distinguishing feature of hydraulics is viscosity.

### 3.3 Characteristics and requirements

### 3.4 Viscosity

The word “viscosity” can be defined as “resistance to flow”. The viscosity of a liquid indicates its internal friction, i.e. the resistance which must be overcome to move two adjacent layers of liquid against each other. Thus, viscosity is a measure of how easily a liquid can be poured.

The international system of standards defines viscosity as “kinematic viscosity” (unit:  $\text{mm}^2/\text{s}$ ).

It is determined by a standardised procedure, e.g.:

DIN 51562: Ubbelohde viscometer;

DIN 51561: Vogel-Ossag viscometer.

The ball viscometer can also be used to determine kinematic viscosity. It can be used to measure viscosity values precisely across a broad area. Measurements are made to determine the speed with which a body sinks in a liquid under the influence of gravity. To find the kinematic viscosity, it is necessary to divide the value determined using the ball viscometer by the density of the fluid.

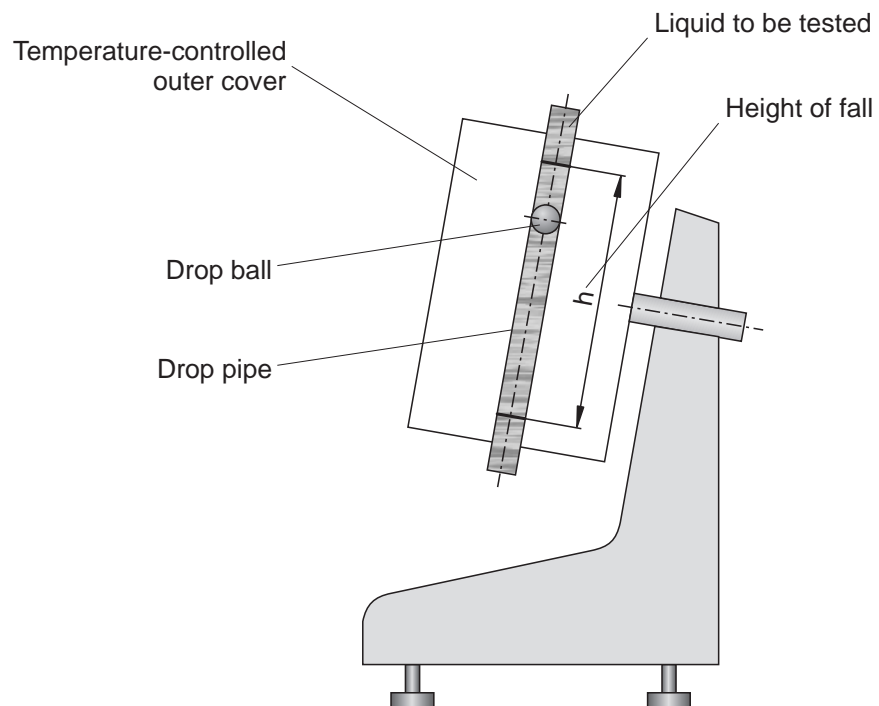

Ball viscometer

One important method of identifying hydraulic oils is the specification of viscosity class. The ISO standard and the new draft of DIN 51524 explain that the viscosity classes lay down the minimum and maximum viscosity of hydraulic oils at 40 °C.

ISO viscosity classes	kinematic viscosity (mm <sup>2</sup> /s) at 40 °C	
	max.	min.
ISO VG 10	9.0	11.0
ISO VG 22	19.8	24.2
ISO VG 32	28.8	35.2
ISO VG 46	41.4	50.6
ISO VG 68	61.2	74.8
ISO VG 100	90.0	110.0

*Viscosity classes  
(DIN 51502)*

Thus, six different viscosity classes are available for the various types of hydraulic oil HL, HLP and HV. The table below specifies areas of application for the different viscosity classes; it is necessary here to match the viscosity class to the ambient temperatures.

For storage reasons, high-grade motor or gear lubricating oil is also used in hydraulic installations. For this reason, the SAE viscosity classification is also listed here. However, this classification allows fairly large tolerance zones as can be seen from a comparison between the two methods of classification.

SAE classes	ISO-VG	Areas of application
30	100	stationary installations in closed areas at high temperatures
20, 20 W	68	
10 W	46	at normal temperatures
5 W	32	for open air applications – mobile hydraulics in colder areas
	22	
	(15)	
	10	

*SAE  
viscosity classification*

In practice **viscosity margins** play an important role:

Where **viscosity is too low** (very fluid), more leakages occur. The lubricating film is thin and, thus, able to break away more easily resulting in reduced protection against wear. Despite this fact, fluid oil is preferred to viscous oil since pressure and power losses are small owing to the lower friction. As viscosity increases, the internal friction of the liquid increases and, with that, the pressure and power loss caused by the heat also increases.

**High viscosity** results in increased friction leading to excessive pressure losses and heating particularly at throttle points. This makes cold start and the separation of air bubbles more difficult and, thus, leads to cavitation.

*Viscosity limits*

	Kinematic viscosity
Lower limit	$10 \frac{\text{mm}^2}{\text{s}}$
Ideal viscosity range	15 to $100 \frac{\text{mm}^2}{\text{s}}$
Upper limit	$750 \frac{\text{mm}^2}{\text{s}}$

When using hydraulic fluids, it is important to consider their viscosity-temperature characteristics, since the viscosity of a hydraulic fluid changes with changes in temperature. These characteristics are shown in the Ubbelohde's viscosity-temperature diagram. If the values are entered on double logarithmic paper, a straight line is produced.

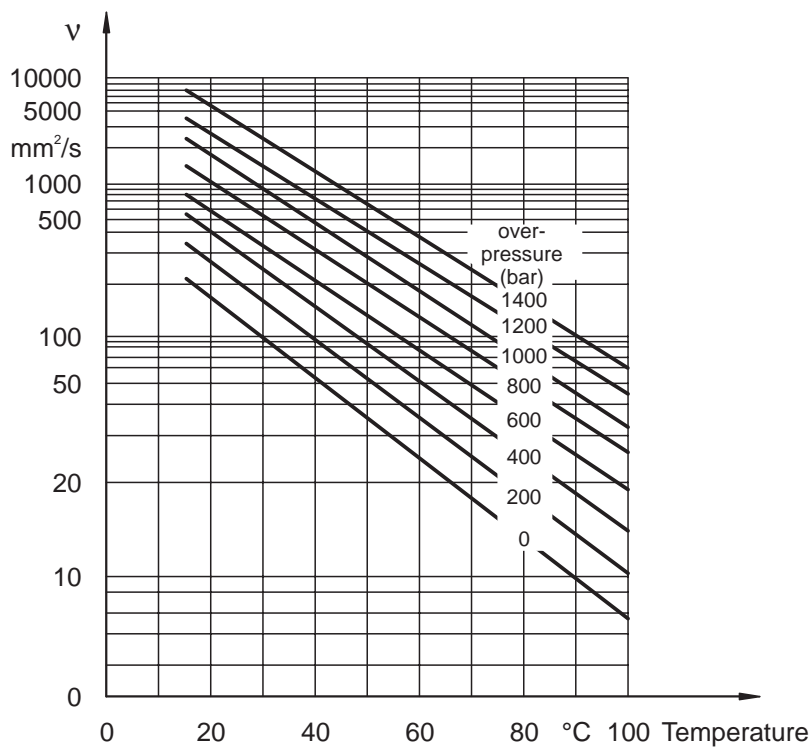

*Ubbelohde's viscosity-temperature diagram*

The **viscosity index** (VI) is used as a reference value for viscosity-temperature characteristics.

It is calculated in accordance with DIN ISO 2909. The higher the viscosity index of a hydraulic oil, the less the viscosity changes or the greater the temperature range in which this hydraulic oil can be used. In the viscosity-temperature diagram, a high viscosity index is shown as a level characteristic line.

Mineral oils with a high viscosity index are also referred to as **multi-grade oils**. They can be used anywhere where very changeable operating temperatures arise; such as for mobile hydraulics, for example. Where oils with a low viscosity index are concerned, a distinction must be made between summer oils and winter oils:

**Summer oils:** with higher viscosity so that the oil does not become too fluid causing the lubricating film to break up.

**Winter oils:** with lower viscosity so that the oil does not become too thick and a cold start is possible.

The **viscosity-pressure characteristics** of hydraulic oils are also important since the viscosity of hydraulic oils increases with increasing pressure. These characteristics are to be noted particularly in the case of pressures from a  $\Delta p$  of 200 bar. At approx. 350 to 400 bar the viscosity is generally already double that at 0 bar.

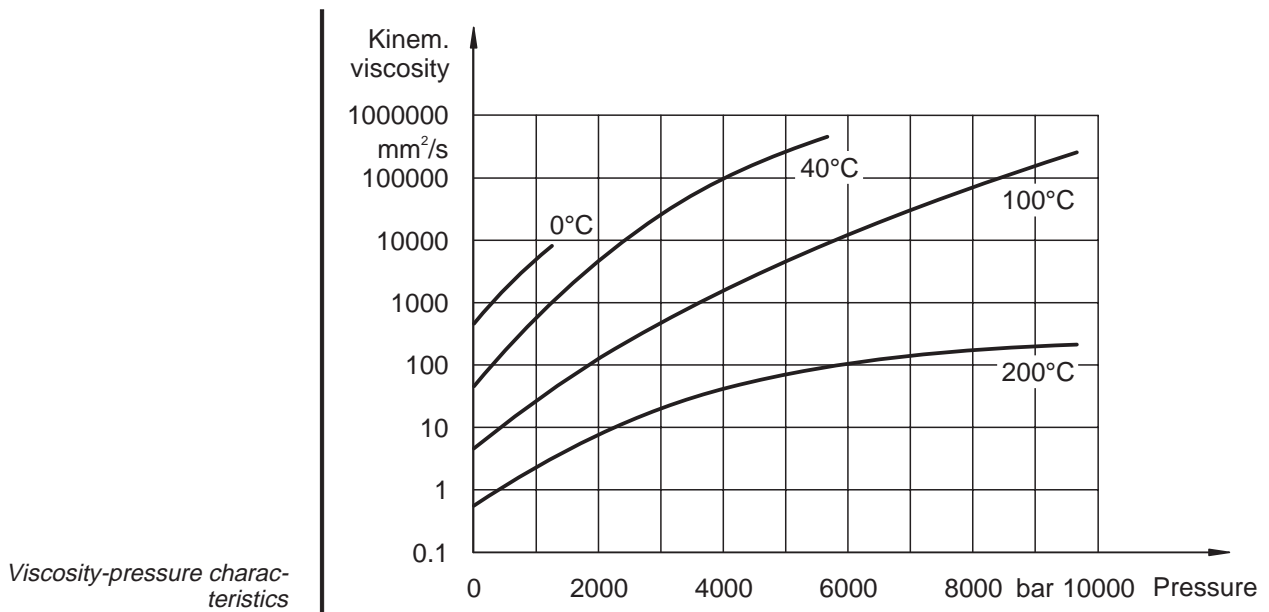



If the characteristics of hydraulic fluids described in this chapter are summarized, the following advantages and disadvantages of hydraulic fluids with low flammability result when compared to hydraulic oils on a mineral oil base:

<b>Advantages and disadvantages of hydraulic fluids with low flammability</b>		
	<b>Advantages</b>	<b>Disadvantages</b>
Greater density		Difficult intake conditions for pumps.
Low compressibility	Hydraulic oil less fluid	Higher pressure peaks possible.
Unfavourable air venting properties		Increase dwell time in reservoir by using larger reservoirs.
Limited operating temperatures		50 °C may not be exceeded as otherwise too much water vaporises.
Favourable viscosity temperature characteristics	In the case of HFC liquids, the viscosity changes less sharply in case of temperature fluctuations.	In the case of HFD liquids, the viscosity changes with temperature fluctuations.
Wearing properties		HFD liquids erode conventional bunan seals, accumulator diaphragms and hoses.
Price	Characteristics of HFD liquids correspond to those of hydraulic oil when appropriate cooling and heating equipment is in use.	HFD liquids are more expensive than hydraulic oils.



## **Chapter 4**

# **Components of a hydraulic system**

The modules and devices used in hydraulic systems are explained in some detail in this chapter.

#### 4.1 Power supply section

The power supply unit provides the necessary **hydraulic power** – by converting the mechanical power from the drive motor.

The most important component in the power supply unit is the **hydraulic pump**. This draws in the hydraulic fluid from a reservoir (tank) and delivers it via a system of lines in the hydraulic installation against the opposing resistances. **Pressure** does not build up until the flowing liquids encounter a resistance.

The **oil filtration unit** is also often contained in the power supply section. Impurities can be introduced into a system as a result of mechanical wear, oil which is hot or cold, or external environmental influences. For this reason, **filters** are installed in the hydraulic circuit to remove dirt particles from the hydraulic fluid. Water and gases in the oil are also disruptive factors and special measures must be taken to remove them.

**Heaters** and **coolers** are also installed for conditioning the hydraulic fluid. The extent to which this is necessary depends on the requirements of the particular exercise for which the hydraulic system is being used.

The reservoir itself also plays a part in conditioning the hydraulic fluid:

- Filtering and gas separation by built-in baffle plates,
- Cooling through its surface.

#### 4.2 Hydraulic fluid

This is the working medium which transfers the prepared energy from the power supply unit to the drive section (cylinders or motors). Hydraulic fluids have a wide variety of characteristics. Therefore, they must be selected to suit the application in question. Requirements vary from problem to problem. Hydraulic fluids on a mineral oil base are frequently used; these are referred to as **hydraulic oils**.

Valves are devices for controlling the energy flow. They can control and regulate the flow direction of the hydraulic fluid, the pressure, the flow rate and, consequently, the flow velocity.

### 4.3 Valves

There are four valve types selected in accordance with the problem in question.

#### **Directional control valves**

These valves control the direction of flow of the hydraulic fluid and, thus, the direction of motion and the positioning of the working components.

Directional control valves may be actuated manually, mechanically, electrically, pneumatically or hydraulically.

They convert and amplify signals (manual, electric or pneumatic) forming an interface between the power control section and the signal control section.

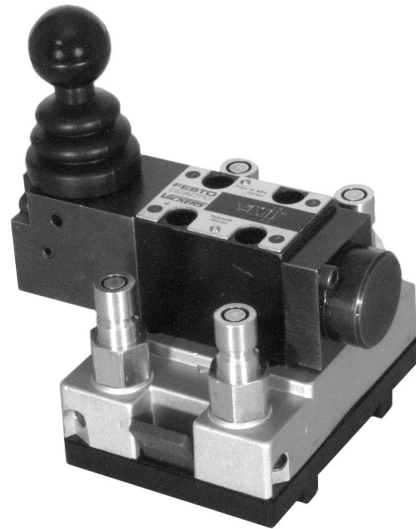

*Directional control valve*

**Pressure valves**

These have the job of influencing the pressure in a complete hydraulic system or in a part of the system. The method of operation of these valves is based on the fact that the effective pressure from the system acts on a surface in the valve. The resultant force is balanced out by a counteracting spring.

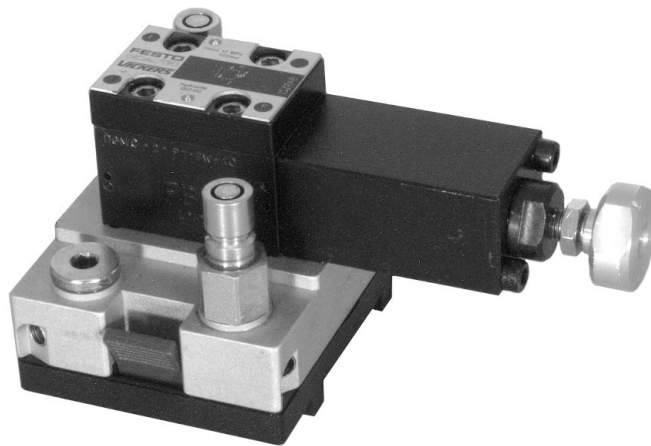

*Pressure relief valve*

**Flow control valves**

These interact with pressure valves to affect the flow rate. They make it possible to control or regulate the speed of motion of the power components. Where the flow rate is constant, division of flow must take place. This is generally effected through the interaction of the flow control valve with a pressure valve.

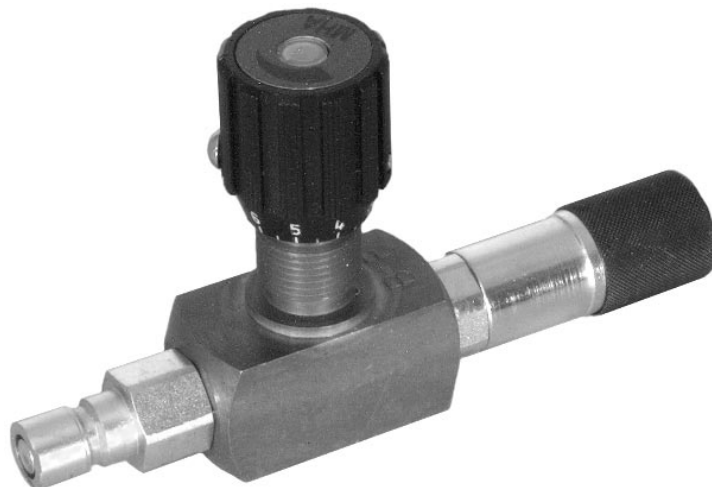

*Flow control valve*

**Non-return valves**

In the case of this type of valve, a distinction is made between ordinary non-return valves and piloted non-return valves. In the case of the **piloted non-return valves**, flow in the blocked direction can be released by a signal.



*Non-return valve*

#### 4.4 Cylinders (linear actuators)

Cylinders are drive components which convert hydraulic power into mechanical power. They generate linear movements through the pressure on the surface of the movable piston. Distinction is made between the following types of cylinder:

##### Single-acting cylinders

The fluid pressure can only be applied to one side of the piston with the result that the drive movement is only produced in one direction. The return stroke of the piston is effected by an external force or by a return spring.

Examples:

- Hydraulic ram
- Telescopic cylinder

##### Double-acting cylinders

The fluid pressure can be applied to either side of the piston meaning that drive movements are produced in two directions.

Examples:

- Telescopic cylinder
- Differential cylinder
- Synchronous cylinder

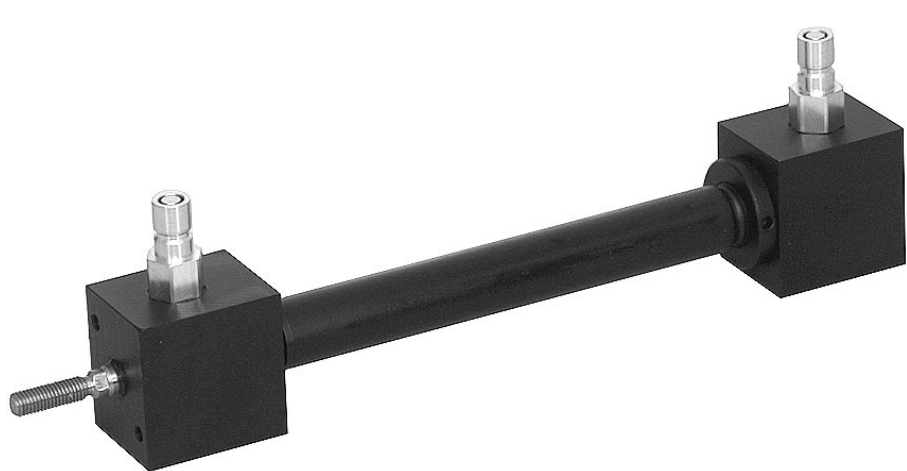

*Double-acting cylinder*



Like cylinders, **hydraulic motors** are drive components controlled by valves. They too convert hydraulic power into mechanical power with the difference that they generate rotary or swivel movements instead of linear movements.

#### 4.5 Motors (rotary actuators)

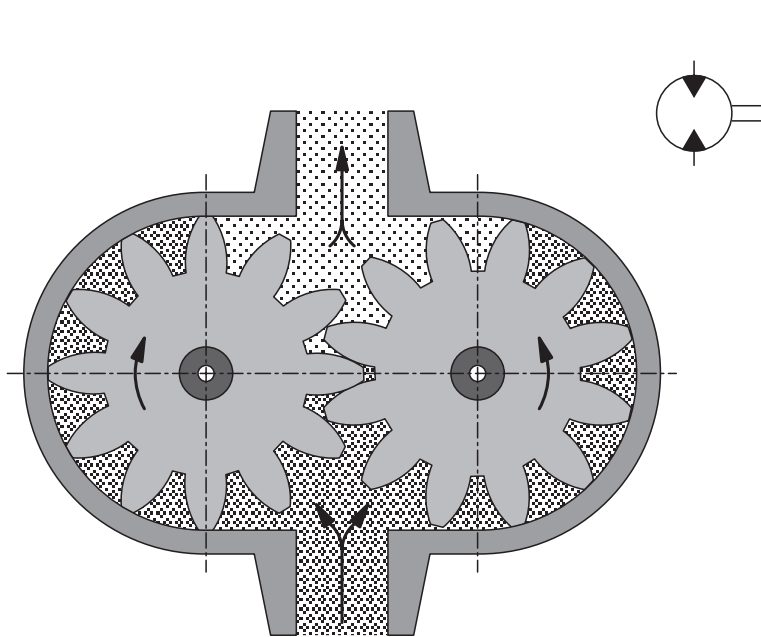

Hydraulic motor  
(gear motor)



# Chapter 5

## Graphic and circuit symbols

Simple graphic and circuit **symbols** are used for individual **components** to enable clear representation of hydraulic systems in diagrams. A symbol identifies a component and its function, but it does not provide any information about its design. The symbols to be used are laid down in DIN ISO 1219. The most important symbols are dealt with in this chapter. The function of the components is explained in Section B.

Note: An arrow drawn at an angle through the symbol indicates that setting possibilities exist.

**5.1 Pumps and motors**

Hydraulic pumps and motors are represented by means of a circle which shows where the drive or output shaft is located. Triangles within the circle give information about the direction of flow. These triangles are filled in, since hydraulic fluids are used for hydraulics. If a gaseous pressure medium were being used, as is the case in pneumatics, the triangles would not be filled in. The symbols for hydraulic motors and hydraulic pumps can only be distinguished from one another by the fact that the arrows indicating the direction of flow are drawn pointing one way for the pumps and the other for the motors.

**Hydraulic pumps with fixed displacement**

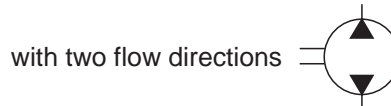
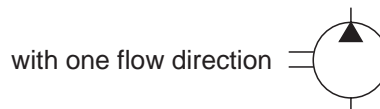

**Hydraulic motors with fixed displacement**

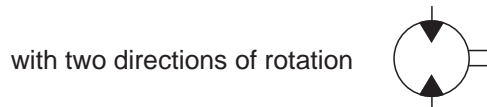
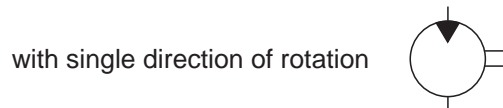

▲ Fluids  
△ Gases

*Fixed displacement hydraulic motors and pumps*

Directional control valves are shown by means of several connected squares.

- The number of squares indicates the number of switching positions possible for a valve.
- Arrows within the squares indicate the flow direction.
- Lines indicate how the ports are interconnected in the various switching positions.

There are two possible methods of **port designation**. One method is to use the letters P, T, A, B and L, the other is to label ports alphabetically A, B, C, D, etc. The former method is generally preferred. Ports should always be labelled with the valve in the rest position. Where there is no rest position, they are allocated to the switching position assumed by the valve when the system is in its initial position.

The rest position is defined as the position automatically assumed by the valve on removal of the actuating force.

## 5.2 Directional control valves

When labelling directional control valves, it is first necessary to specify the number of ports followed by the number of switching positions. Directional control valves have at least two switching positions and at least two ports. In such an instance, the valve would be designated a 2/2-way valve. The following diagrams show other directional control valves and their circuit symbols.

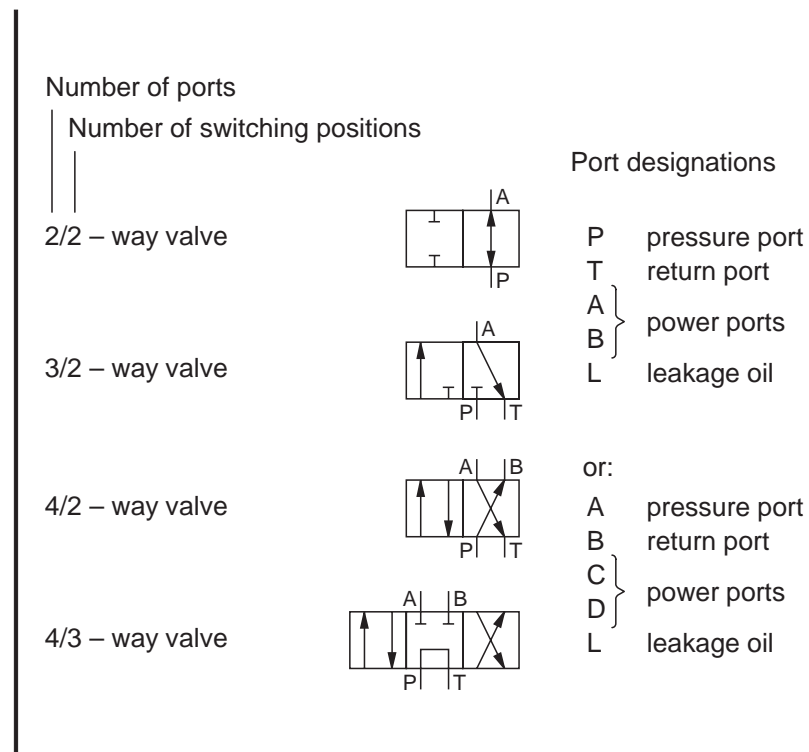



Directional control valves

The switching position of a directional control valve can be changed by various actuation methods. The symbol for the valve is elaborated by the addition of the symbol indicating the actuation method. In the case of some of the actuation methods shown, such as push button, pedal, lever with detent, a spring is always necessary for resetting. Resetting may also be achieved by switching the valve a second time, e.g. in the case of a valve with hand lever and detent setting.

Listed below are the symbols for the most important actuation methods. Refer to DIN ISO 1219 for other methods of actuation.

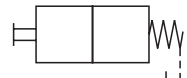
### 5.3 Methods of actuation

general symbol with spring return and bleed port 

by push button with spring return 

by lever 

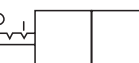
by lever with detent setting 

by pedal and spring return 

*Mechanical actuation*

by stem or push button



by spring



by roller stem



*General symbol*

\* Type of actuation to be specified where no standard symbol exists





Pressure valves are represented using squares. The flow direction is indicated by an arrow. The valve ports can be labeled P (pressure port) and T (tank connection) or A and B.

The position of the valve within the square indicates whether the valve is normally open or normally closed.

**5.4 Pressure valves**

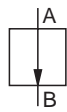

open

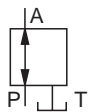

flow from  
P to A  
T closed

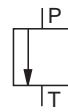

closed

Pressure valves

A further distinction is made between **set** and **adjustable pressure valves**. The latter are indicated by a diagonal arrow through the spring.

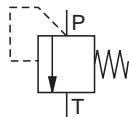

set

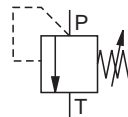

adjustable

Pressure valves

Pressure valves are divided into **pressure relief valves** and **pressure regulators**:

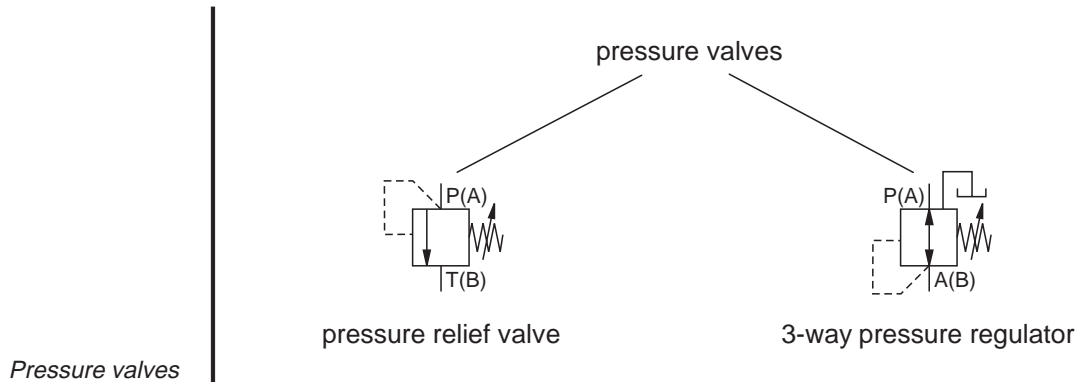

**Pressure relief valve** In the normally closed position the control pressure is detected at the input. This pressure acts on a valve via the control passage coming from the input on a piston surface which is held against the control pressure by a spring. If the force resulting from the pressure and the effective piston surface exceeds the spring force, the valve opens. In this way, it is possible to set the limiting pressure to a fixed value.

**Pressure regulator** In the case of a normally open pressure regulator, the control pressure is detected at the output. This pressure is effective in the valve via the control passage on a piston surface and generates a force. This force works against a spring. The valve begins to close when the output pressure is greater than the spring force. This closing process causes a pressure drop from the input to the output of the valve (caused by the flow control). When the output pressure reaches a specified value, the valve closes completely. The specified maximum system pressure is set at the input of the valve, the reduced system pressure at the output. Thus, the pressure regulator can only be set to a smaller setting value than that set at the pressure relief valve.

In the case of flow control valves, a distinction is made between those affected by viscosity and those unaffected. Flow control valves unaffected by viscosity are termed orifices. Throttles constitute resistances in a hydraulic system.

**5.5 Flow control valves**

The 2-way flow control valve consists of two restrictors, one setting restrictor unaffected by viscosity (orifice) and one adjustable throttle. The adjustable throttle gap is modified by changes in pressure. This adjustable throttle is also known as a pressure balance. These valves are depicted as a rectangle into which are drawn the symbol for the variable throttle and an arrow to represent the pressure balance. The diagonal arrow running through the rectangle indicates that the valve is adjustable. There is a special symbol to represent the 2-way flow control valve.

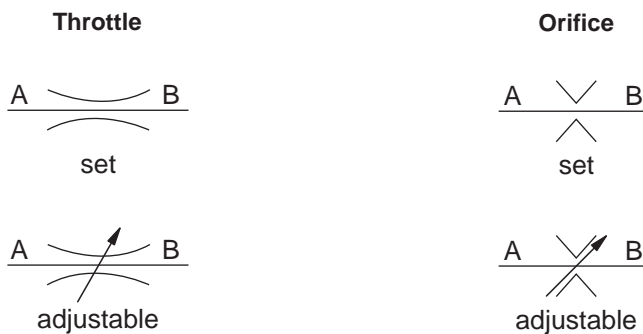

Throttle and orifice

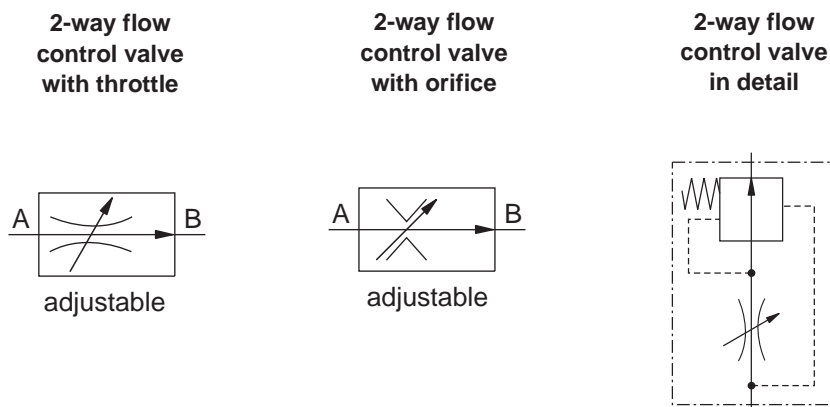

2-way flow control valve

**5.6 Non-return valves**

The symbol for non-return valves is a ball which is pressed against a sealing seat. This seat is drawn as an open triangle in which the ball rests. The point of the triangle indicates the blocked direction and not the flow direction.

Pilot controlled non-return valves are shown as a square into which the symbol for the non-return valve is drawn. The pilot control for the valve is indicated by a control connection shown in the form of a broken line. The pilot port is labelled with the letter X.

Shut-off valves are shown in circuit diagrams as two triangles facing one another. They are used to depressurise the systems manually or to relieve accumulators. In principle, wherever lines have to be opened or closed manually.

*Non-return valve*



spring loaded



unloaded

*Shut-off valve and pilot-controlled non-return valve*

**Shut-off valve**



**pilot-controlled non-return valve**



Cylinders are classified as either single-acting or double-acting.

Single acting cylinders just have one port, i.e. only the full piston surface can be pressurised with hydraulic fluid. These cylinders are returned either by the effect of external forces – indicated by the symbol with the open bearing cap – or by a spring. The spring is then also drawn into the symbol.

## 5.7 Cylinders

Single acting cylinder

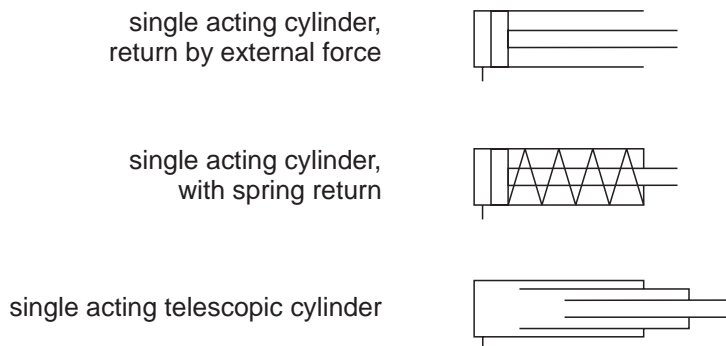

Single acting cylinder

Double acting cylinders have two ports for supplying either side of the piston with hydraulic fluid.

Double acting cylinder

It can be seen from the symbol for a double acting cylinder with **single piston rod** that the piston area is greater than the annular piston surface.



Conversely, the symbol for the cylinder with **a through piston rod** shows that these areas are of the same size (synchronous cylinder).

The symbol for the **differential cylinder** can be distinguished from that for the double-acting cylinder by the two lines added to the end of the piston rod. The area ratio is 2:1.

Like single-acting **telescopic cylinders**, double-acting ones are symbolized by pistons located one inside the other.



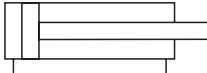
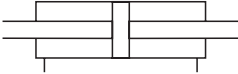
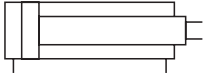

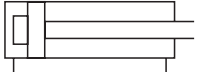
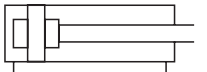
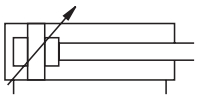







In the case of the double-acting **cylinder with end position cushioning**, the cushioning piston is indicated in the symbol by a rectangle.

*Double-acting cylinders*

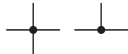
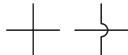
double-acting cylinder with single piston rod	
double-acting cylinder with through piston rod	
differential cylinder	
double-acting telescopic cylinder	
double-acting cylinder with single end position cushioning	
double-acting cylinder with end position cushioning at both ends	
double acting cylinder with adjustable end position cushioning at both ends	

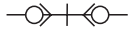
The following symbols are used in circuit diagrams for energy transfer and conditioning of the pressure medium.

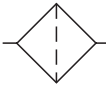
**5.8 Transfer of energy and conditioning of the pressure medium**

hydraulic pressure source	
electric motor	
non-electric drive unit	
pressure, power, return line	
control (pilot) line	
flexible line	
line connection	
lines crossing	
exhaust, continuous	
quick-acting coupling connected with mechanically opening non-return valves	
reservoir	
filter	
cooler	
heater	

*Energy transfer and conditioning of the pressure medium*

### 5.9 Measuring devices

Measuring devices are shown in the circuit diagrams by the following symbols:

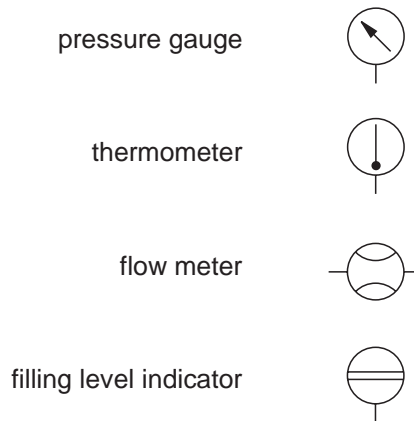

### 5.10 Combination of devices

If several devices are brought together in a single housing, the symbols for the individual devices are placed into a box made up of broken lines from which the connections are led away.

Hydraulic power pack

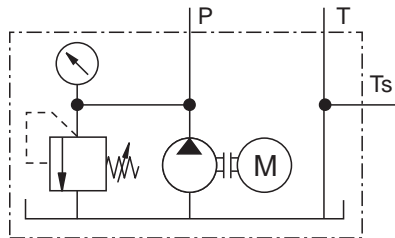

Pilot-operated double non-return valve

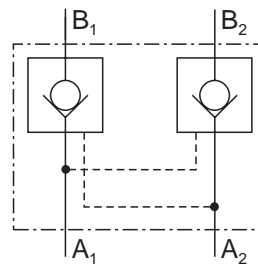



## **Chapter 6**

# **Design and representation of a hydraulic system**

A hydraulic system can be divided into the following sections:

- The signal control section
- The power section

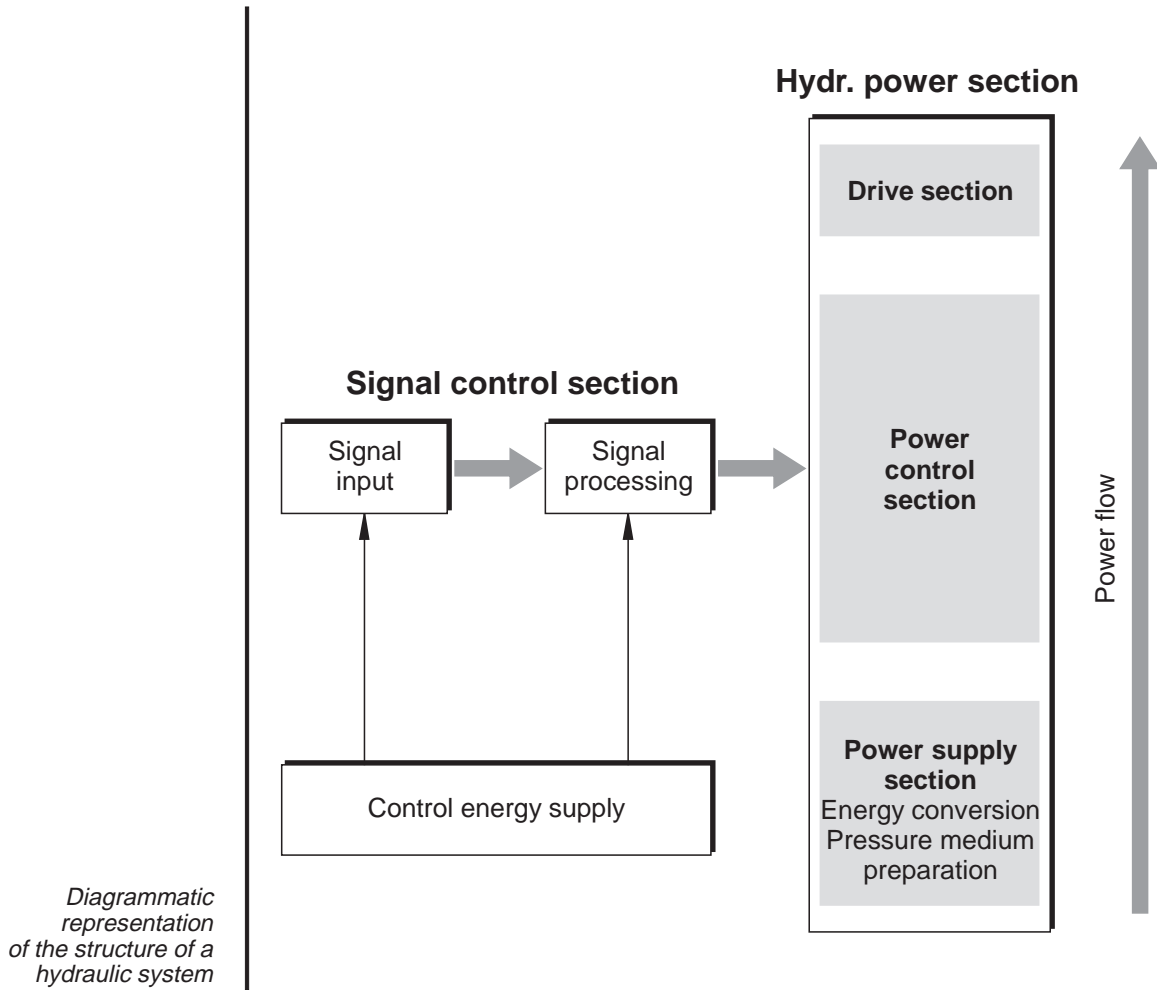

*Diagrammatic representation of the structure of a hydraulic system*

The signal control section is divided into **signal input** (sensing) and **signal processing** (processing).

## 6.1 Signal control section

Signal input may be carried out:

- manually
- mechanically
- contactlessly

Signals can be **processed** by the following means:

- by the operator
- by electricity
- by electronics
- by pneumatics
- by mechanics
- by hydraulics

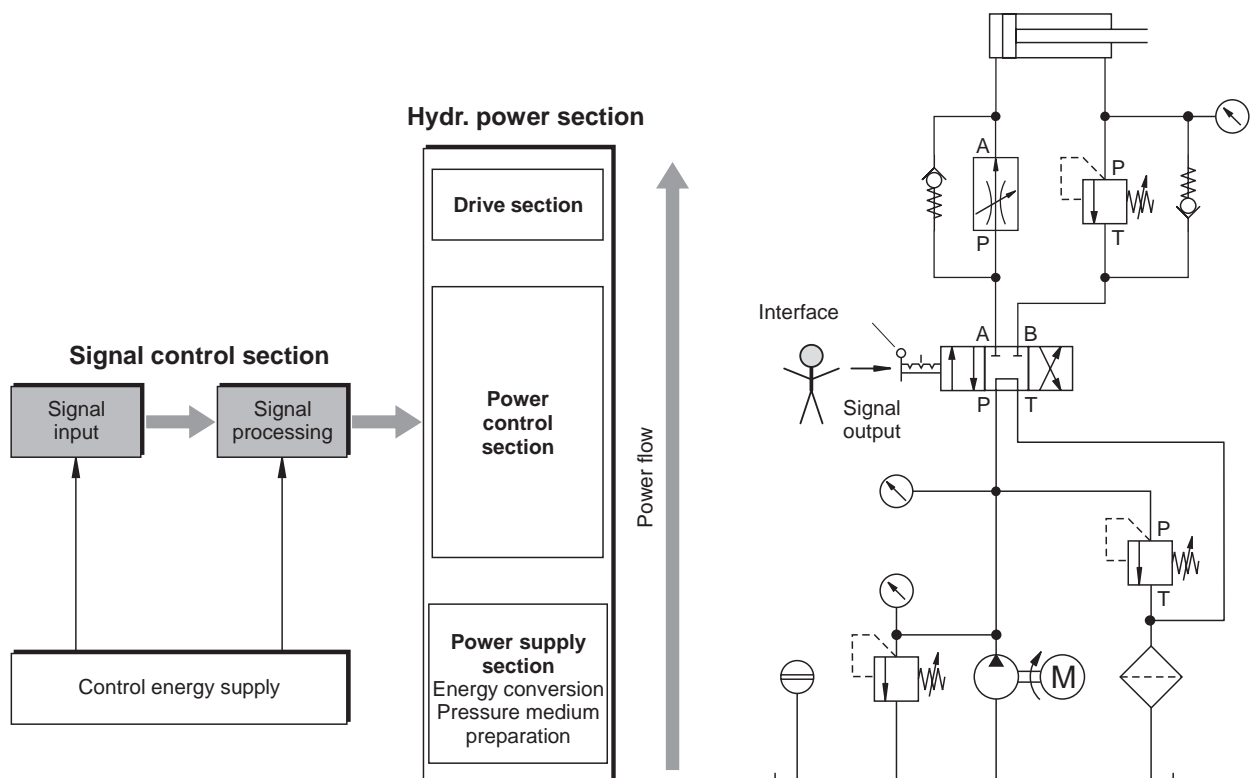

Hydraulic system – Design

## 6.2 Hydraulic power section

The hydraulic power can be divided up into the **power supply section**, the **power control section** and the **drive section** (working section).

The **power supply section** is made up of the energy conversion part and the pressure medium conditioning part. In this part of the hydraulic system, the hydraulic power is generated and the pressure medium conditioned. The following components are used for energy conversion – converting electrical energy into mechanical and then into hydraulic energy:

- Electric motor
- Internal combustion engine
- Coupling
- Pump
- Pressure indicator
- Protective circuitry

The following components are used to condition the hydraulic fluid:

- Filter
- Cooler
- Heater
- Thermometer
- Pressure gauge
- Hydraulic fluid
- Reservoir
- Filling level indicator

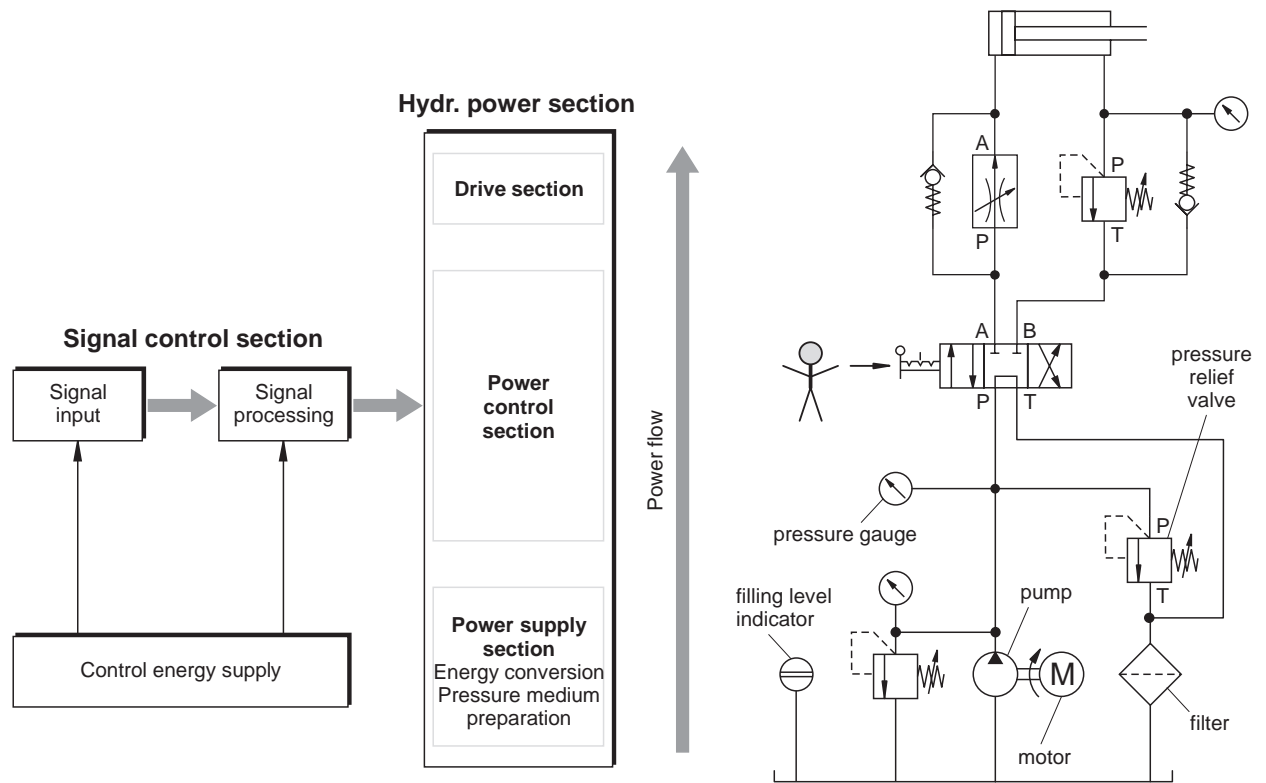

Hydraulic system – Design

The power is supplied to the drive section by the **power control section** in accordance with the control problem. The following components perform this task:

- directional control valves
- flow control valves
- pressure valves
- non-return valves.

The **drive section** of a hydraulic system is the part of the system which executes the various working movements of a machine or manufacturing system. The energy contained in the hydraulic fluid is used for the execution of movements or the generation of forces (e. g. clamping processes). This is achieved using the following components:

- cylinders
- motors.

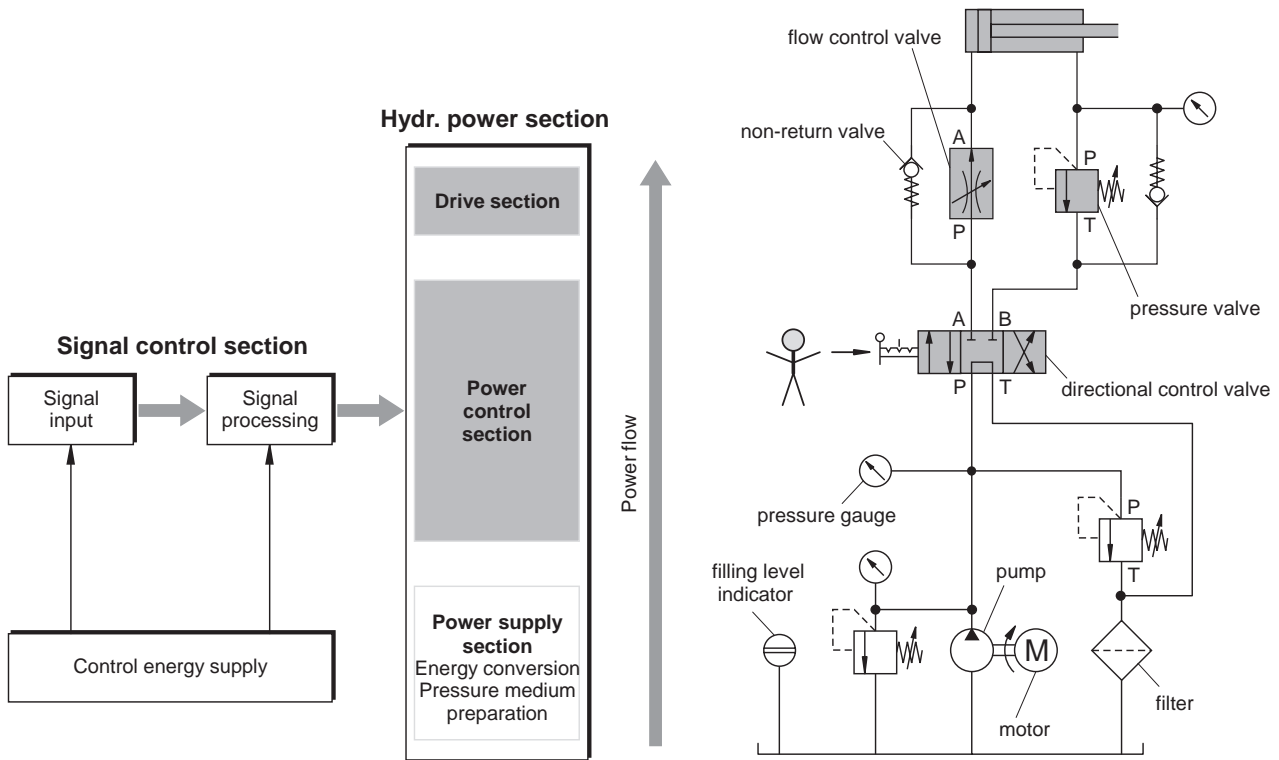

Hydraulic system – Design

A suitable type of representation is required in order to reproduce movement sequences and operating statuses of working elements and control elements clearly.

The following types of representation are of importance:

- positional sketch
- circuit diagram
- displacement-step diagram
- displacement-time diagram
- function diagram
- function chart.

The positional sketch is a drawing or schematic diagram of a production installation or machine etc. It should be easily understandable and should include only the most important information. It shows the spatial arrangement of the components.

The positional sketch in the Figure shows the position of cylinder Z1 and its function:

Z1 is intended to lift the hood of the tempering furnace.

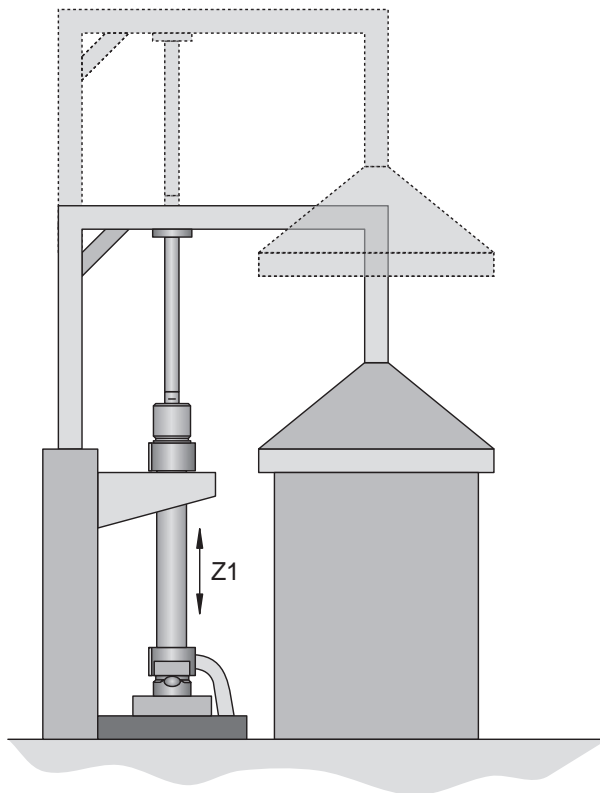

*Positional sketch*

### 6.3 Positional sketch

**6.4 Circuit diagram**

The circuit diagram describes the functional structure of the hydraulic system.

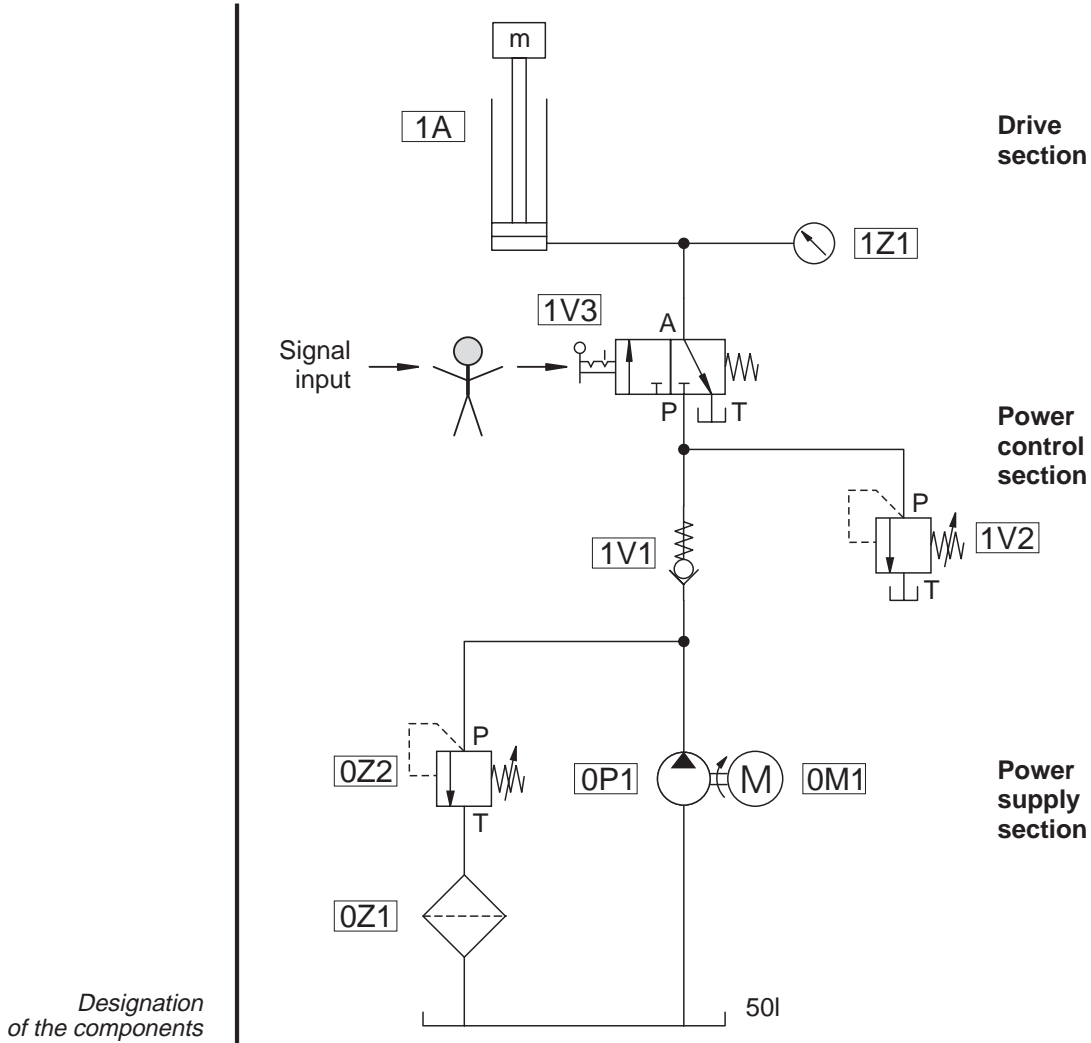

The power supply section of the system with filter (0Z1), pressure-relief valve (0Z2), pump (0P1) and electric motor (0M1) is depicted in the lower part of the circuit diagram shown for the hydraulic device of the tempering furnace.

The power control section with the non-return valve (1V1), the 3/2-way valve (1V3) and the pressure-relief valve (1V2) is located in the centre of the circuit diagram. The 3/2-way valve (1V3) with the hand lever for signal input forms the “system-person” interface.

Like the drive section, the power control section is assigned to the power section. In this hydraulic device, the drive section consists of the single-acting cylinder 1A.



In the circuit diagram, the technical data are often additionally specified with the devices in accordance with DIN 24347.

**6.5 Components plus technical data**

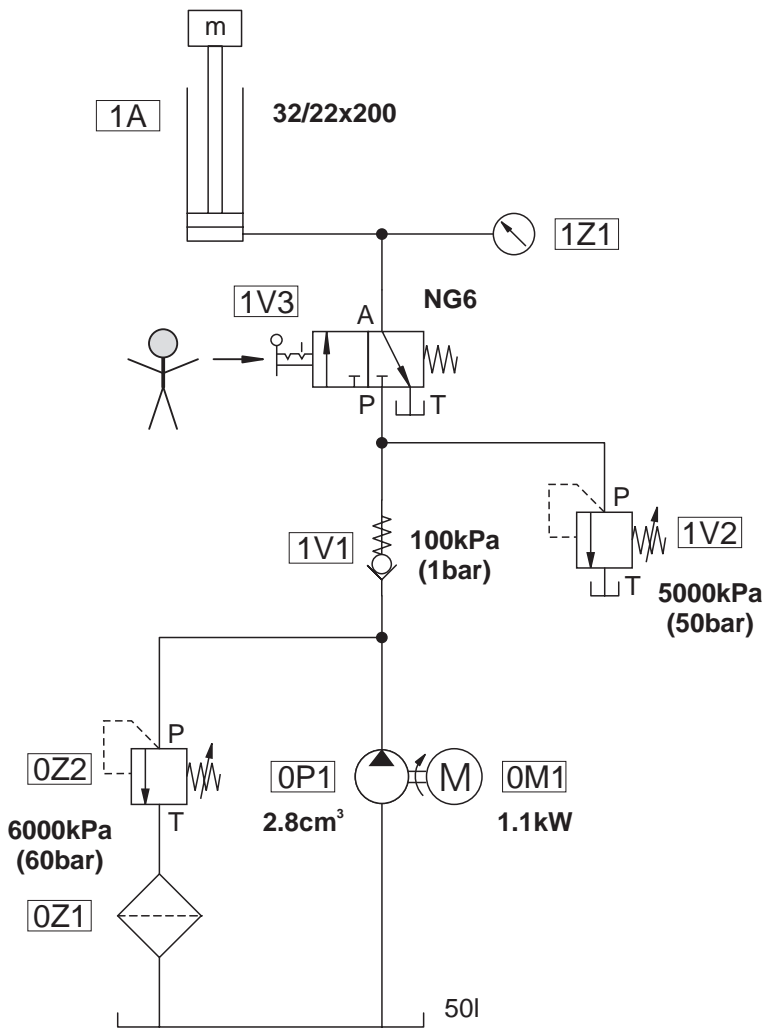

*Circuit diagram with technical data*

Furthermore, the circuit diagram can be supplemented by tables:

Equipment	Specifications	Example values
Reservoirs	Volume in litres to the highest permissible oil level	Max. 50 l
	Type of hydraulic fluid	ISO VG 22 type AI or HLP
Electric motors	Rated capacity in kW	1.1 kW
	Rated speed in rpm	1420 rpm
Fixed displacement pumps and variable-displacement pumps	Geometric delivery rate in cm <sup>3</sup>	Gear pump 2.8 cm <sup>3</sup> /revolution
Pressure valves	Set pressure in bar or permissible pressure range for the system	Operating pressure 50 bar
Non-return valve	Opening pressure	1 bar
Cylinder	Cylinder inner diameter/piston rod diameter • stroke in mm. The function (e. g. clamping, lifting, flat turning etc.) must be entered above every cylinder	32/22 • 200 1A lifting
Filter	Nominal flow rate in l/min $\beta_{...at} \quad \Delta p_{...bar}$	
Flexible hose	Nominal diameter (inner diameter) in mm	6 mm
Hydraulic motor	Capacity in cm <sup>3</sup> Speed in rpm	v = 12.9 cm <sup>3</sup> n = 1162.8 rpm at Q = 15 cm <sup>3</sup> /min M = 1 Nm
Directional control valve	Nominal size	NG 6
Filter	Nominal flow rate in l/min $\beta_{...at} \quad \Delta p_{...bar}$	32/22 • 200

Function diagrams of working machines and production installations can be represented graphically in the form of diagrams. These diagrams are called function diagrams. They represent statuses and changes in status of individual components of a working machine or production installation in an easily understood and clear manner. The following example shows a lifting device controlled by electromagnetic directional control valves.

**6.6 Function diagram**

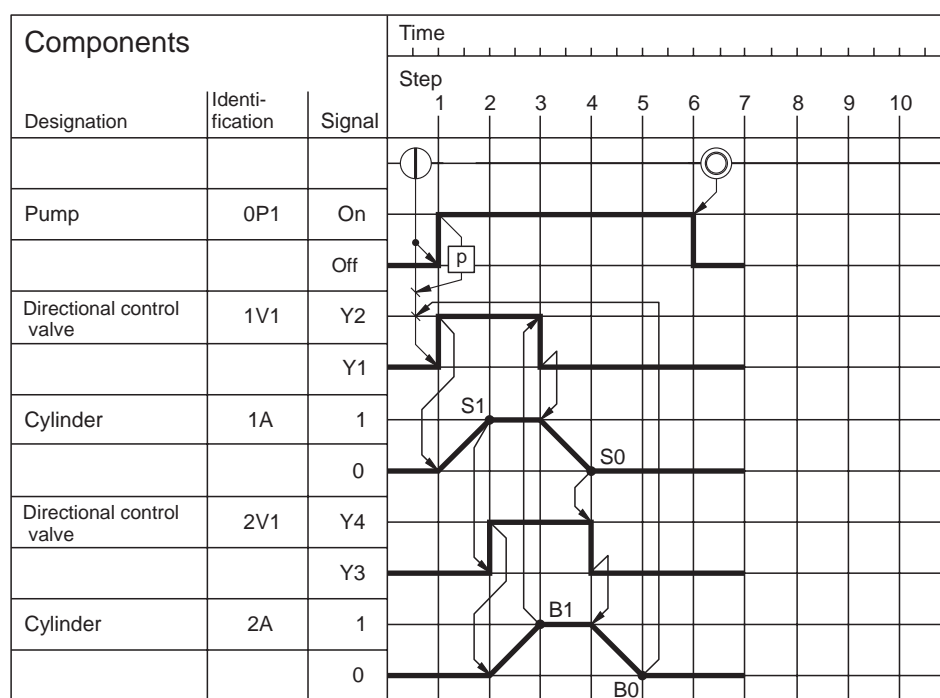

Function diagram

**6.7 Function chart** A function chart is a flow chart in which the control sequence is strictly divided into steps. Each step is executed only after the previous step has been completed and all step enabling conditions have been fulfilled.

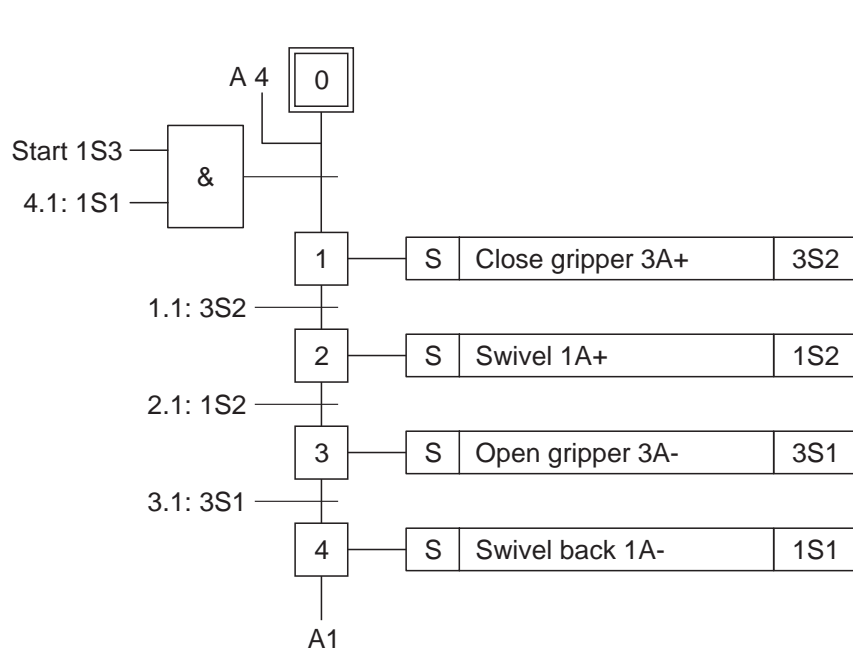

Function chart

## **Chapter 7**

# **Components of the Power Supply Section**

The power supply section provides the energy required by the hydraulic system. The most important components in this section are:

- drive
- pump
- pressure relief valve
- coupling
- reservoir
- filter
- cooler
- heater.

In addition, every hydraulic system contains service, monitoring and safety devices and lines for the connection of hydraulic components.

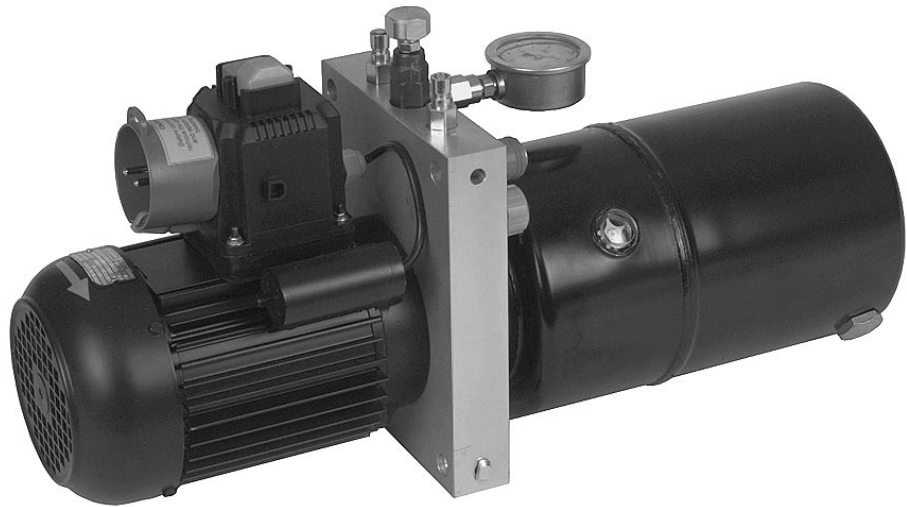

*Hydraulic power unit*

Hydraulic systems (with the exception of hand pumps) are driven by motors (electric motors, combustion engines).

Electrical motors generally provide the mechanical power for the pump in stationary hydraulics, whilst in mobile hydraulics combustion engines are normally used.

## 7.1 Drive

In larger machines and systems, the central hydraulics are of importance. All consuming devices in a system with one or several hydraulic power supply units and with the help of one or more reservoirs are supplied via a common pressure line. The hydraulic reservoir stores hydraulic power which is released as required. The reservoir is dealt with in greater detail in the TP502 Advanced Course.

Pressure, return and waste oil lines are all ring lines. Space and power requirements are reduced by employing this type of design.

This diagram shows a processing station from a transfer line.

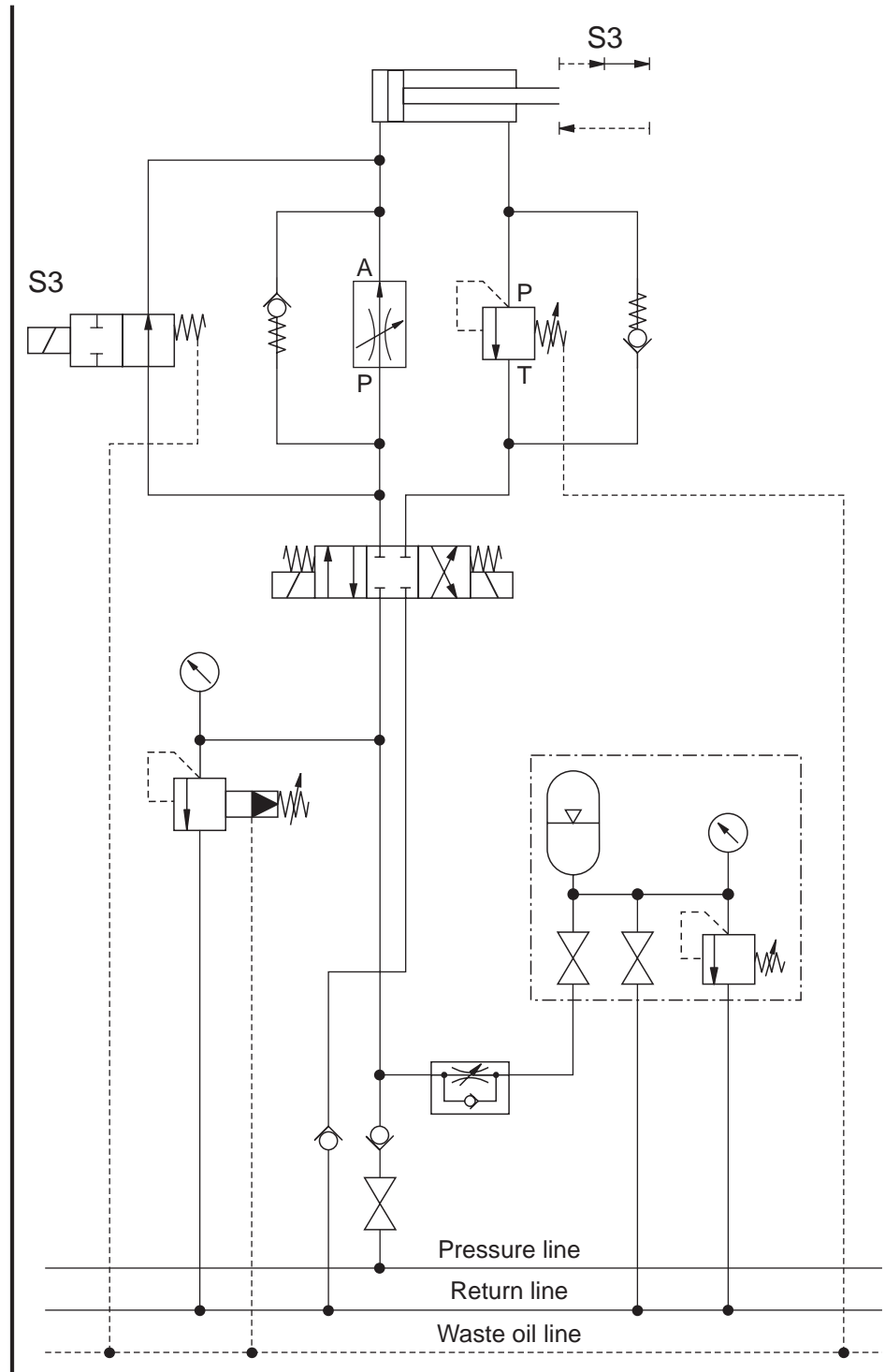

Circuit diagram



The pump in a hydraulic system, also known as a hydraulic pump, converts the mechanical energy in a drive unit into hydraulic energy (pressure energy).

The pump draws in the hydraulic fluid and drives it out into a system of lines. The resistances encountered by the flowing hydraulic fluid cause a pressure to build up in the hydraulic system. The level of the pressure corresponds to the total resistance which results from the **internal** and **external resistances** and the flow rate.

- External resistances:  
come about as a result of maximum loads and mechanical friction and static load and acceleration forces.
- Internal resistances:  
come about as a result of the total friction in the lines and components, the viscous friction and the flow losses (throttle points).

Thus, the fluid pressure in a hydraulic system is not predetermined by the pump. It builds up in accordance with the resistances – in extreme cases until a component is damaged. In practice, however, this is prevented by installing a pressure relief valve directly after the pump or in the pump housing at which the maximum operating pressure recommended for the pump is set.

## 7.2 Pump

The following **characteristic values** are of importance for the pump:

**Displacement volume** The displacement volume  $V$  (also known as the volumetric displacement or working volume) is a measure of the size of the pump. It indicates the volume of liquid supplied by the pump per rotation (or per stroke).

The volume of liquid supplied per minute is designated as volumetric flow rate  $Q$  (delivery). This is calculated from the displacement volume  $V$  and the number of rotations  $n$ :

$$Q = n \cdot V$$

**Example** Calculation of the delivery of a gear pump.

Given that:

Number of rotations  $n = 1450$  r.p.m.

Displacement volume  $V = 2.8 \text{ cm}^3$  (per rev.)

To be found:

Delivery  $Q$

$$\begin{aligned} Q &= n \cdot V \\ &= 1450 \text{ r.p.m.} \cdot 2.8 \text{ cm}^3 \\ &= 4060 \frac{\text{cm}^3}{\text{min}} \\ &= 4.06 \frac{\text{dm}^3}{\text{min}} = 4.06 \text{ l/min} \end{aligned}$$

The operating pressure is of significance for the area of application of pumps. Peak pressure is specified. However, this should arise only briefly (see diagram) as otherwise the pump will wear out prematurely.

Operating pressure

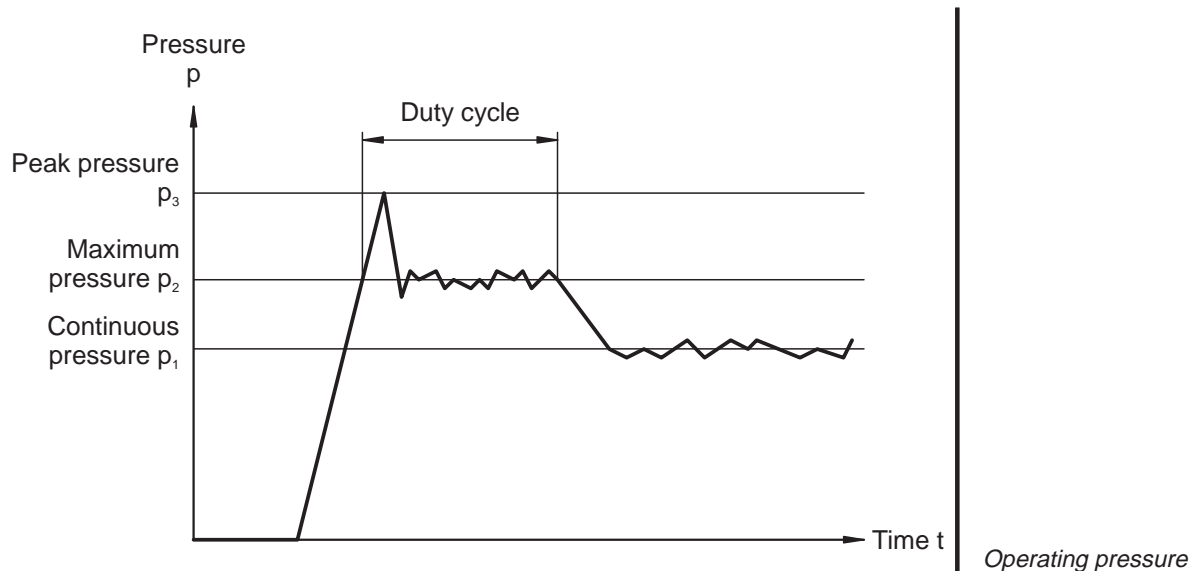

A pressure relief valve is installed in some pumps for safety reasons.

The drive speed is an important criterion for pump selection since the delivery  $Q$  of a pump is dependent on the number of rotations  $n$ . Many pumps are only effective at a specific r.p.m. range and may not be loaded from a standstill. The most usual number of rotations for a pump is  $n = 1500$  r.p.m. since pumps are mainly driven by three-phase asynchronous motors whose number of rotations is not dependent on the supply frequency.

Speeds

Efficiency Mechanical power is converted by pumps into hydraulic power resulting in **power losses** expressed as **efficiency**.  
When calculating the total efficiency  $\eta_{\text{tot}}$  of pumps, it is necessary to take into consideration the volumetric ( $\eta_{\text{vol}}$ ) and the hydro-mechanical ( $\eta_{\text{hm}}$ ) efficiency.

$$\eta_{\text{tot}} = \eta_{\text{vol}} \cdot \eta_{\text{hm}}$$

In practice, characteristic lines are made use of in the evaluation of pumps. VDI recommendation 3279 provides a number of characteristic lines, for example for:

- delivery Q
- power P
- and efficiency  $\eta$

as a function of the pressure at a constant speed.

The characteristic line for the delivery as a function of the pressure is designated the pump characteristic. The pump characteristic shows that the effective pump delivery ( $Q_{\text{eff}}$ ) is reduced according to pressure build-up. The actual delivery ( $Q_w$ ) can be determined when the waste oil from the pump ( $Q_L$ ) is taken into consideration.

A minimum leakage in the pump is necessary to maintain lubrication.

The following information can be derived from the pump characteristic:

- where  $p = 0$ , the pump supplies the complete delivery  $Q$ .
- where  $p > 0$ ,  $Q$  is reduced owing to the leakage oil.
- The course of the characteristic line provides information about the volumetric efficiency ( $\eta_{\text{vol}}$ ) of the pump.

In the diagram, the pump characteristic for a pump in working order and for a worn (defective) pump.

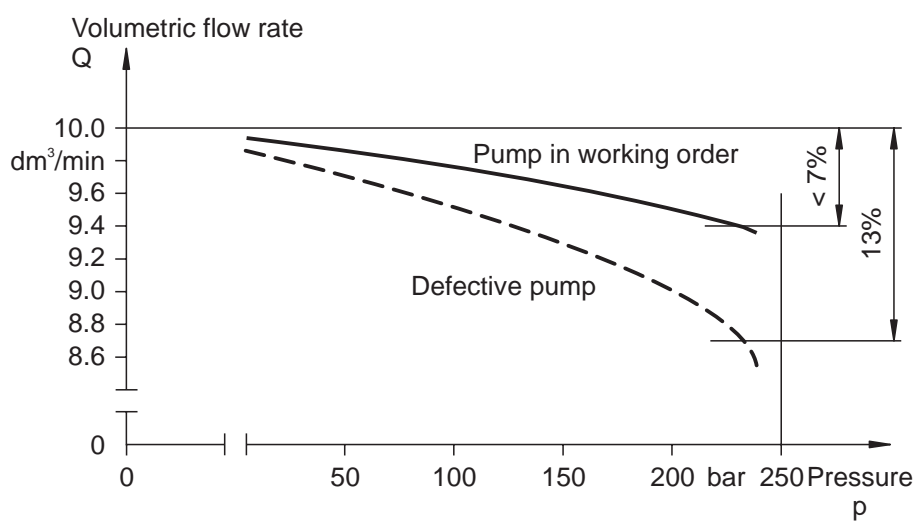

Pump characteristic

- Characteristic for the new pump: The leakage oil from the pump amounts to 6.0 % at 230 bar. This results in:

$$Q_{(p=0)} = 10.0 \text{ dm}^3/\text{min}$$

$$Q_{(p=230)} = 9.4 \text{ dm}^3/\text{min}$$

$$Q_L = 0.6 \text{ dm}^3/\text{min}$$

$$\eta_{\text{vol}} = \frac{9.4 \text{ dm}^3 / \text{min}}{10.0 \text{ dm}^3 / \text{min}}$$

$$\eta_{\text{vol}} = 0.94$$

- Characteristic for the defective pump: The leakage oil from the pump amounts to 14.3 % at 230 bar. This results in:

$$Q_{(p=0)} = 10.0 \text{ dm}^3/\text{min}$$

$$Q_{(p=230)} = 8.7 \text{ dm}^3/\text{min}$$

$$Q_L = 1.3 \text{ dm}^3/\text{min}$$

$$\eta_{\text{vol}} = \frac{8.7 \text{ dm}^3 / \text{min}}{10.0 \text{ dm}^3 / \text{min}}$$

$$\eta_{\text{vol}} = 0.87$$

Therefore, on the basis of the pump characteristic, there is a possibility of calculating the volumetric efficiency ( $\eta_{\text{vol}}$ ) of a pump.

In order to be able to use pumps correctly, the characteristic values and curves which have been described must be known. Using this information, it is easier to compare devices and select the most suitable pump.

Other design features of a pump may also be of significance:

- type of mounting
- operating temperatures
- noise rating
- hydraulic fluid recommendations
- pump type.

Three basic types of hydraulic pump can be distinguished on the basis of the displacement volume:

- **constant pumps**  
fixed displacement volume
- **adjustable pumps**  
adjustable displacement volume
- **variable capacity pumps**  
regulation of pressure, flow rate or power, regulated displacement volume.

Hydraulic pump designs vary considerably; however, they all operate according to the displacement principle. The displacement of hydraulic fluid into the connected system is effected, for example, by piston, rotary vane, screw spindle or gear.

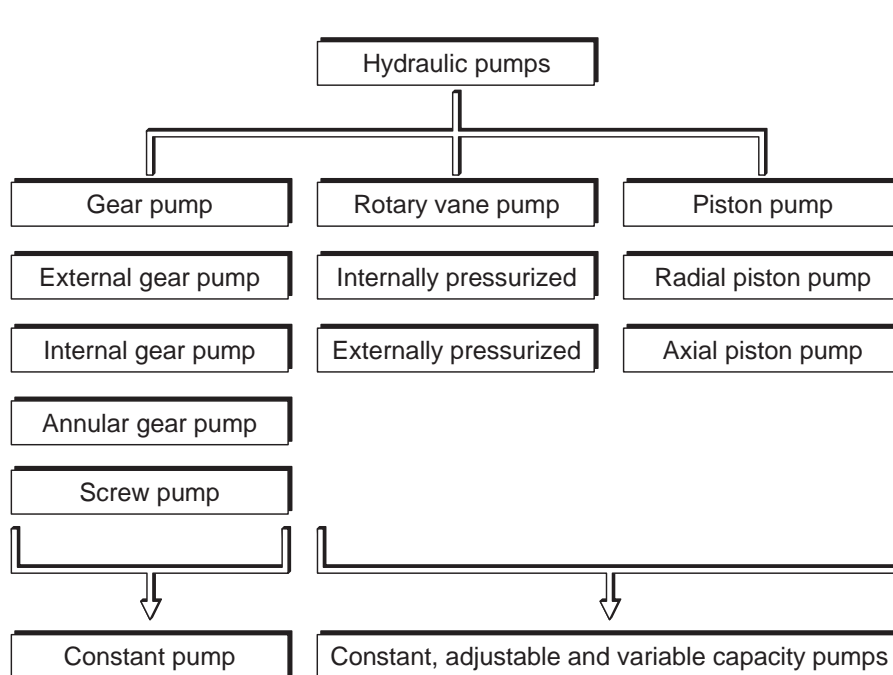

Hydraulic pumps

Example Hydraulic pump: gear pump

Gear pumps are fixed displacement pumps since the displaced volume which is determined by the tooth gap is not adjustable.

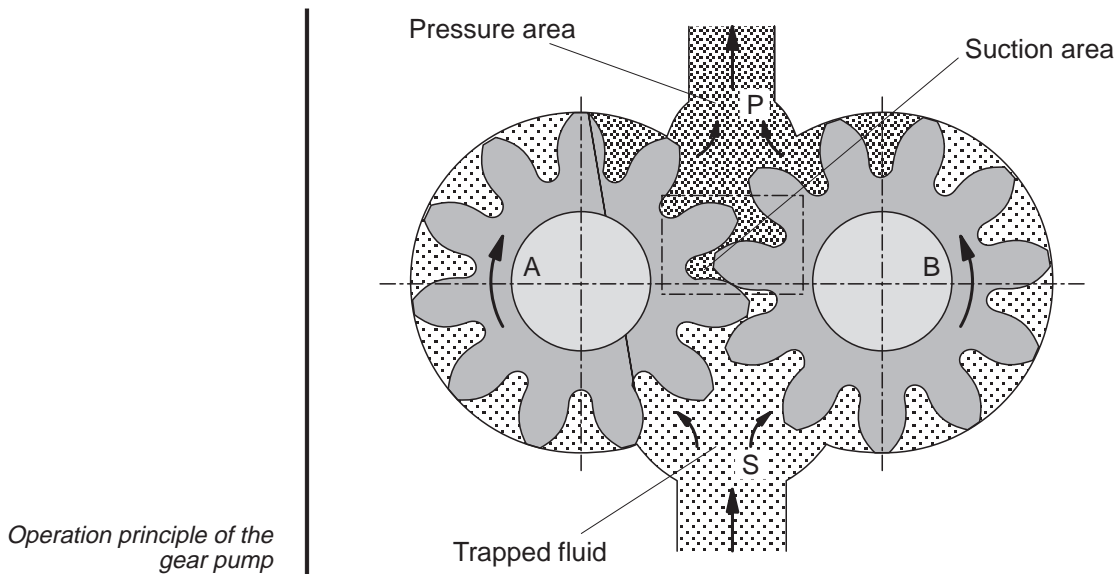

The gear pump shown in the diagram is in section. The suction area S is connected to the reservoir. The gear pump operates according to the following principle:

One gear is connected to the drive, the other is turned by the meshing teeth. The increase in volume which is produced when a tooth moves out of a mesh causes a vacuum to be generated in the suction area. The hydraulic fluid fills the tooth gaps and is conveyed externally around the housing into pressure area P. The hydraulic fluid is then forced out of the tooth gaps by the meshing of teeth and displaced into the lines.

Fluid is trapped in the gaps between the teeth between suction and pressure area. This liquid is fed to the pressure area via a groove since pressure peaks may arise owing to compression of the trapped oil, resulting in noise and damage.



The **leakage oil** from the pump is determined by the size of the gap (between housing, tips of the teeth and lateral faces of the teeth), the overlapping of the gears, the viscosity and the speed.

These losses can be calculated from the volumetric efficiency since this indicates the relationship between the effective and the theoretically possible delivery.



Owing to the minimal permissible flow velocity, the **suction area** in the suction lines is greater than the **pressure area**. The result of an undersize suction pipe cross-section would be a higher flow velocity since the following is valid for v:

$$v = \frac{Q}{A}$$

Where there is a constant flow rate and a smaller cross section, an increase in the flow velocity results. Consequently, pressure energy would be converted into motion energy and thermal energy and there would be a pressure drop in the suction area. Since, whilst hydraulic fluid is being drawn into the suction area, there is a vacuum in the suction area, this would increase resulting in cavitation. In time, the pump would be damaged by the effects of cavitation.

The characteristic values and pump characteristics are of importance for the correct selection and application of pumps.

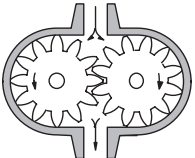
The table below lists the characteristic values for the most common constant pumps. Characteristic values for other hydraulic pumps are contained in VDI recommendation 3279.

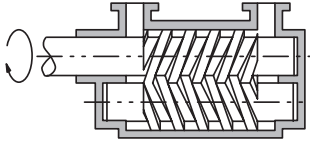
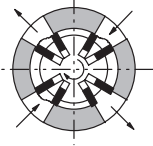
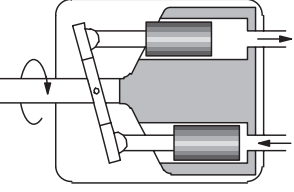
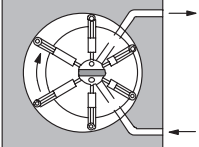
	Types of design	Speed range r.p.m.	Displacement volume (cm <sup>3</sup> )	Nominal pressure (bar)	Total efficiency
	Gear pump, internally toothed	500 - 3500	1.2 - 250	63 - 160	0.8 - 0.91
	Gear pump, externally toothed	500 - 3500	4 - 250	160 - 250	0.8 - 0.91
	Screw pump	500 - 4000	4 - 630	25 - 160	0.7 - 0.84
	Rotary vane pump	960 - 3000	5 - 160	100 - 160	0.8 - 0.93
	Axial piston pump	..... - 3000 750 - 3000 750 - 3000	100 25 - 800 25 - 800	200 160 - 250 160 - 320	0.8 - 0.92 0.82 - 0.92 0.8 - 0.92
	Radial piston pump	960 - 3000	5 - 160	160 - 320	0.90

Couplings are located in the power supply section between the motor and the pump. They transfer the turning moment generated by the motor to the pump.

In addition, they cushion the two devices against one another. This prevents fluctuations in the operation of the motor being transferred to the pump and pressure peaks at the pump being transferred to the motor. In addition, couplings enable the balancing out of errors of alignment for the motor and pump shaft.

Examples:

- rubber couplings
- spiral bevel gear couplings
- square tooth clutch with plastic inserts.

### 7.3 Coupling

The reservoir in a hydraulic system fulfils several tasks. It:

- acts as intake and storage reservoir for the hydraulic fluid required for operation of the system;
- dissipates heat;
- separates air, water and solid materials;
- supports a built-in or built-on pump and drive motor and other hydraulic components, such as valves, accumulators, etc.

### 7.4 Reservoir

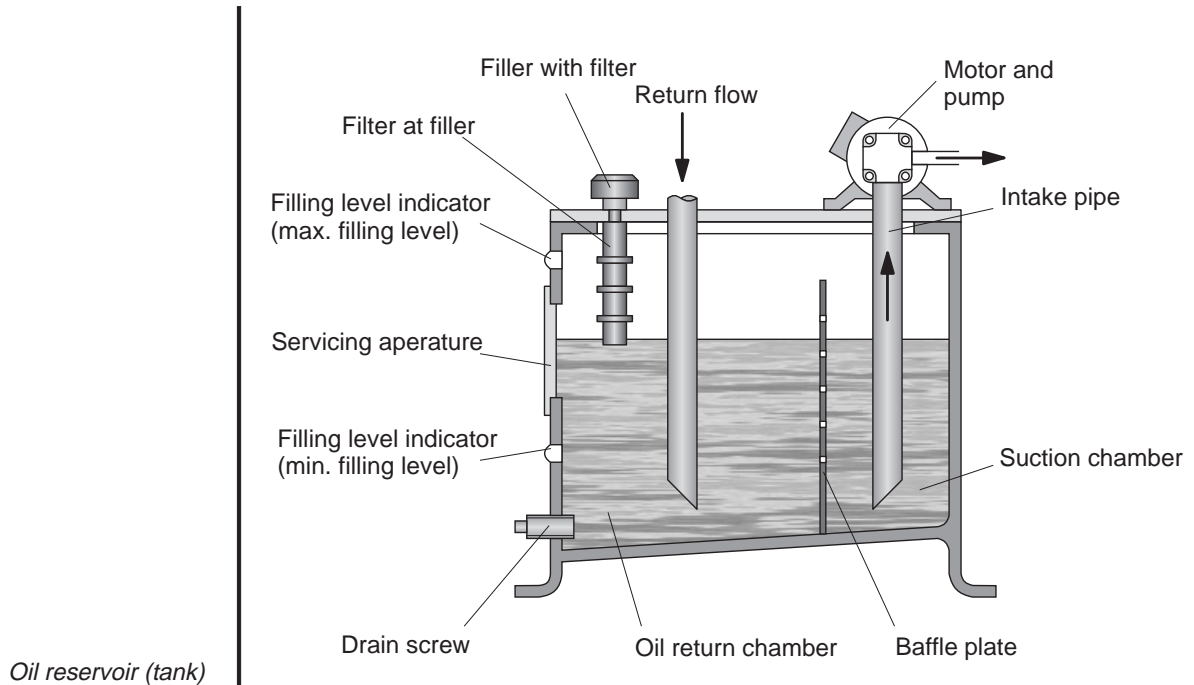

From these functions, the following guidelines can be drawn up for the design of the reservoir.

Reservoir size, dependent on:

- pump delivery
- the heat resulting from operation in connection with the maximum permissible liquid temperature
- the maximum possible difference in the volume of liquid which is produced when supplying and relieving consuming devices (e.g. cylinders, hydraulic fluid reservoirs)
- the place of application
- the circulation time.

The volume of liquid supplied by the pump in 3 to 5 minutes can be used as a reference value for deciding the size of reservoir required for stationary systems. In addition, a volume of approx. 15% must be provided to balance out fluctuations in level.

Since mobile hydraulic reservoirs are smaller for reasons of space and weight, they alone are not able to perform the cooling operations (other cooling equipment is necessary).

#### **Reservoir shape**

High reservoirs are good for heat dissipation, wide ones for air separation.

#### **Intake and return lines**

These should be as far away from one another as possible and should be located as far beneath the lowest oil level as possible.

#### **Baffle and separating plate**

This is used to separate the intake and return areas. In addition, it allows a longer settling time for the oil and, therefore, makes possible more effective separation of dirt, water and air.

#### **Base plate**

The base of the tank should slope down to the drain screw so that the deposited sediment and water can be flushed out.

#### **Ventilation and exhaust (air filter)**

To balance the pressure in case of a fluctuating oil level, the reservoir must be ventilated and exhausted. For this purpose, a ventilation filter is generally integrated into the filler cap of the feed opening.

Ventilation and exhaust are not necessary in the case of closed reservoirs as used for mobile hydraulics. There, a flexible bladder which is prestressed by a gas cushion (nitrogen) is built into the air-tight container. Because of this, there are fewer problems with pollution through contact with air and water and premature ageing of the hydraulic fluid with these containers. At the same time, prestressing prevents cavitation in the intake line since there is a higher pressure in the reservoir.

**7.5 Filters** Filters are of great significance in hydraulic systems for the reliable functioning and long service life of the components.

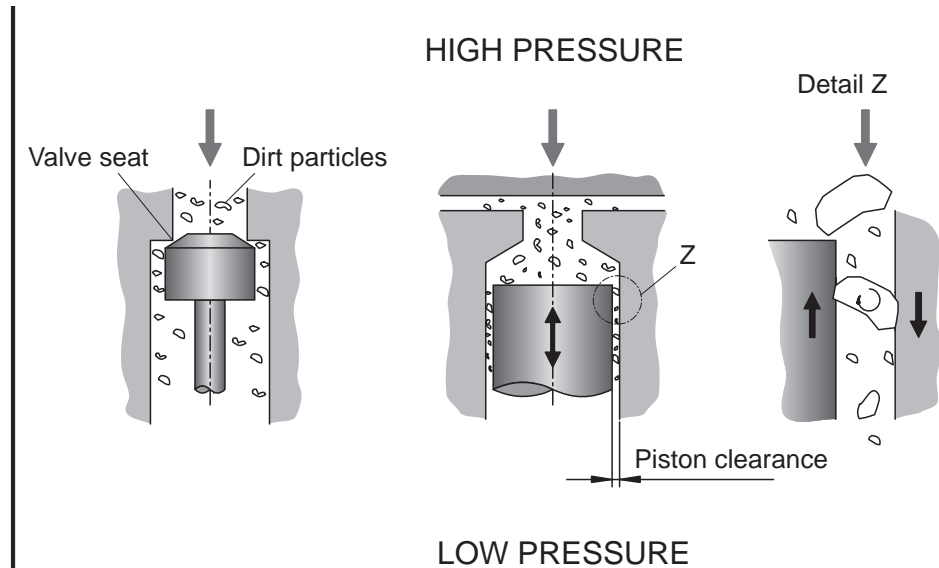

*Effects of polluted oil*

Contamination of the hydraulic fluid is caused by:

- Initial contamination during commissioning by metal chips, foundry sand, dust, welding beads, scale, paint, dirt, sealing materials, contaminated hydraulic fluid (supplied condition).
- Dirt contamination during operation owing to wear, ingress via seals and tank ventilation, filling up or changing the hydraulic fluid, exchanging components, replacing hoses.

It is the task of the filter to reduce this contamination to an acceptable level in order to protect the various components from excessive wear. It is necessary to use the correct grade of filter and a contamination indicator is required in order to check the efficiency of the filter. Systems are often flushed using economical filters before commissioning.

Selection and positioning of the filter is largely based on the sensitivity to dirt of the hydraulic components in use.

Dirt particles are measured in  $\mu\text{m}$ , the grade of filtration is indicated accordingly. Distinction is made between: Grade of filtration

- **Absolute filter fineness**  
indicates the largest particle able to pass through a filter;
- **Nominal filter fineness**  
particles of nominal pore size are arrested on passing through several times;
- **Average pore size**  
measurement of the average pore size for a filter medium as defined in the Gaussian process;
- **$\beta$ -value**  
indicates how many times more particles above a specific size are located in the filter intake than in the filter return;

$\beta_{50} = 10$  means that 10 x as many particles larger than 50  $\mu\text{m}$  are located in the filter intake than in the filter outlet. Example

Proposed grade of filtration x in $\mu\text{m}$ , where $\beta x = 100$	Type of hydraulic system
1 - 2	To prevent the most fine degree of contamination in highly sensitive systems with an exceptionally high level of reliability; mainly used for aeronautics or laboratory conditions.
2 - 5	Sensitive, powerful control and regulating systems in the high pressure range; frequently used for aeronautics, robots and machine tools.
5 - 10	Expensive industrial hydraulic systems offering considerable operational reliability and a planned service life for individual components.
10 - 20	General hydraulic and mobile hydraulic systems, average pressure and size.
15 - 25	Systems for heavy industry or those with a limited service life.
20 - 40	Low pressure systems with considerable play.

*Grades of filtration and areas of application*

**Return filtering** Return filters are built straight onto the oil reservoir, return power filters are installed in the return line. The housing and filter insert must be designed in such a way as to stand up to pressure peaks which may occur as a result of large valves opening suddenly or oil being diverted directly to the reservoir via a by-pass valve with fast response. The complete return flow is to flow back through the filter. If the return flow is not concentrated in a common line, the filter may also be used for the partial flow (in the by-pass flow). Return filtering is cheaper than high pressure filtering.

### Important characteristic values

Operating pressure	depending on design, up to max. 30 bar
Flow rate	up to 1300 l/min (in the case of filters for reservoir installation) up to 3900 l/min (large, upright filters for pipeline installation)
Grade of filtration	10 - 25 $\mu\text{m}$
Perm. differential pressure $\Delta p$	Up to approx. 70 bar, dependent on the design of the filter element.

Double filters are used to avoid down times for filter maintenance. In this type of design, two filters are arranged parallel to one another. If the system is switched over to the second filter, the contaminated one can be removed without the system having to shut down.

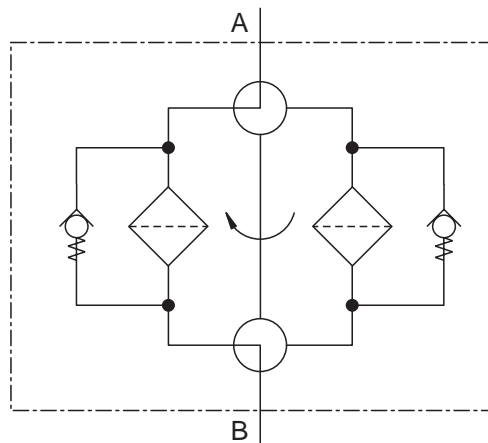

Filter unit, reversible



These filters are located in the suction line of the pump; as a result, the hydraulic fluid is drawn from the reservoir through the filter. Only filtered oil reaches the system.

Suction filters

#### Important characteristic values:

Grade of filtration: 60 - 100 $\mu$ m

These filters are mainly used in systems where the required cleanliness of the hydraulic fluid cannot be guaranteed. They are purely to protect the pump, and exhibit a low degree of filtration as particles of 0.06 - 0.1 mm are still able to pass through the filter. In addition, they aggravate pump intake as a result of a considerable fall in pressure or an increased degree of filter contamination.

Consequently, these filters must not be equipped with fine elements as a vacuum would be built up by the pump leading to cavitation. In order to ensure that these intake problems do not occur, suction filters are equipped with by-pass valves.

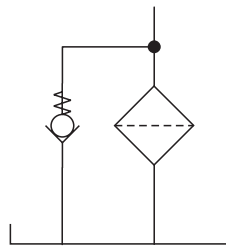

Suction filter with by-pass

These filters are installed in the pressure line of a hydraulic system ahead of devices which are sensitive to dirt, e.g. at the pressure port of the pump, ahead of valves or flow control valves. Since this filter is subjected to the maximum operating pressure, it must be of robust design. It should not have a by-pass but should have a contamination indicator.

Pressure filters

#### Important characteristic values

Operating pressure	up to 420 bar
Flow	up to 330 l/m
Grade of filtration	3 - 5 $\mu$ m
Perm. pressure difference $\Delta p$	up to 200 bar, depending on the design of the filter element.

## Filter arrangement

Hydraulic filters can be arranged in various different positions within a system. A distinction is made between

- filtering of the main flow: return, inlet and pressure filtering
- filtering of the by-pass flow: only one part of the delivery is filtered.

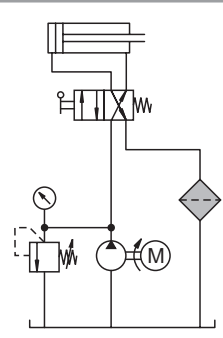
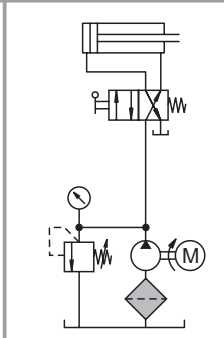
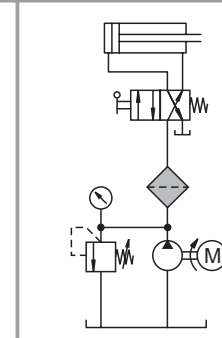
Filtering of the main flow			
	<b>Return flow filter</b>	<b>Pump inlet filter</b>	<b>Pressure line filter</b>
	Advantages	economical simple maintenance	protects pump from contamination
Dis-advantages	contamination can only be checked having passed through the hydraulic components	difficult access, inlet problems with fine pored filters. Result: cavitation	expensive
Remarks	frequently used	can also be used ahead of the pump as a coarse filter	requires a pressure-tight housing and contamination indicator

Filtering of the main flow

	<b>By-pass flow filtering</b>
Advantages	smaller filter possible as an additional filter
Dis-advantages	lower dirt-filtering capacity
Remarks	only part of the delivery is filtered

*By-pass flow filtering*

The various possible filter arrangements are listed in the two diagrams above. The most favourable filter arrangement is decided by considering the sensitivity to dirt of the components to be protected, the degree of contamination of the hydraulic fluid and the costs involved

*Recommended grades of filtration*

Hydraulic devices	Filtration principle	Arrangement of the filter in the circuit	Nominal filter in $\mu\text{m}$
Axial piston machine	Full flow filter	Return line and/or pressure line	$\leq 25$
		Low pressure line	$\leq 25$ (10)
Gear pumps, radial piston pumps. directional control valves, pressure valves, flow valves, non-return valves working cylinders	Full flow filter	Return line	$\leq 63$
	Partial flow filter (additional)	Inlet line	$\leq 63$
Average speed hydraulic motors	Full flow filter	Return line	$\leq 25$

**Surface filters** These filters consist of a thin layer of woven fabric, e.g. metal gauze, cellulose or plastic fabric. These are disposable filters which are suitable for flushing processes and for commissioning a system.

**Deep-bed filters** These may be made of compressed or multi-layered fabric, cellulose, plastic, glass or metal fibres or may contain a sintered metal insert. These filters have a high dirt retention capacity across the same filter area.

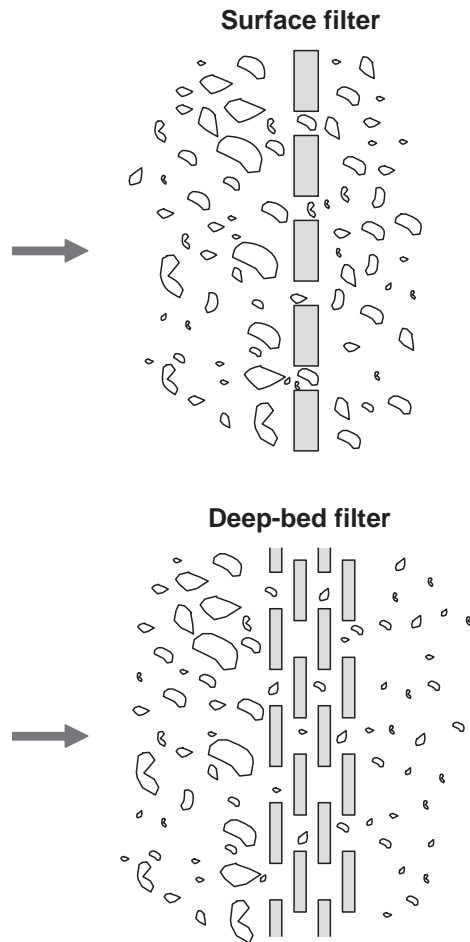

Filter design

Filters generally have star-shaped folds in the filter material. In this way, a very large filter area is achieved with a very small volume.

Specific characteristics are determined by the filter material, the grade of filtration and the application possibilities. These are shown in the table below.

Element type	Grade of filtration (µm)	Application characteristics
Absolute filter $\beta_x = 75$	3, 5, 10, 20	Safeguards operation and service life of sensitive components, e.g. servo and proportional valves.
<b>Nominal filter</b>  Polyester Paper Mat/web Metal Web	1, 5, 10, 20	Safeguards operation and service life of less sensitive components; low flow resistance; good dirt retention capacity.
Wire gauze Braid weave	25 25, 50, 100	Water and liquids which are difficult to ignite, employing special steel filter material; high differential pressure resistance; high dirt retention capacity. Operating temperature of 120 °C possible in special design.

*Selection criteria for filter components (HYDAC Co.)*

Every filter causes a pressure drop. The following reference values apply here:

#### **Main stream filtering**

Pressure filter  $\Delta p \sim 1$  to 1.5 bar at operating temperature

Return line filter  $\Delta p \sim 0.5$  bar at operating temperature

Intake filter 1  $\Delta p \sim 0.05$  to 0.1 bar at operating temperature.

### By-pass flow filtering

The by-pass pump delivery should be approx. 10% of the tank content. To keep pressure losses low, the filter should be made sufficiently large. Viscosity also has an effect on total pressure loss as does the grade of filtration and flow rate.

The viscosity factor  $f$  and the pressure loss  $\Delta p$  from the housing and filter element are specified by the manufacturer.

The total differential pressure of the complete filter is calculated as follows:

$$\Delta p_{\text{total}} = \Delta p_{\text{housing}} + f \cdot \Delta p_{\text{element}}$$

### Determining the differential pressure for a pressure filter

Example

A pressure loss  $\Delta p_{\text{total}}$  is to be calculated for a flow rate of 15 l/min. Filter fineness is to be 10 $\mu\text{m}$ , kinematic viscosity  $\nu = 30 \text{ mm}^2/\text{s}$ . The following diagrams are shown as examples of company specifications.

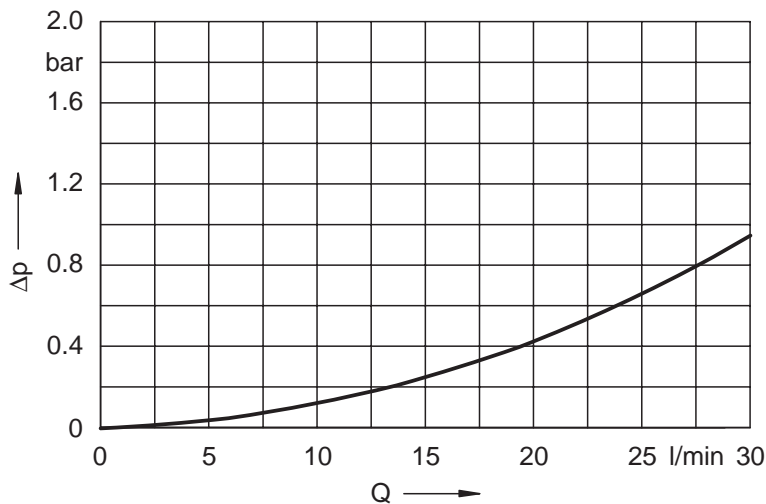

Housing characteristic

Pressure filter-element characteristic

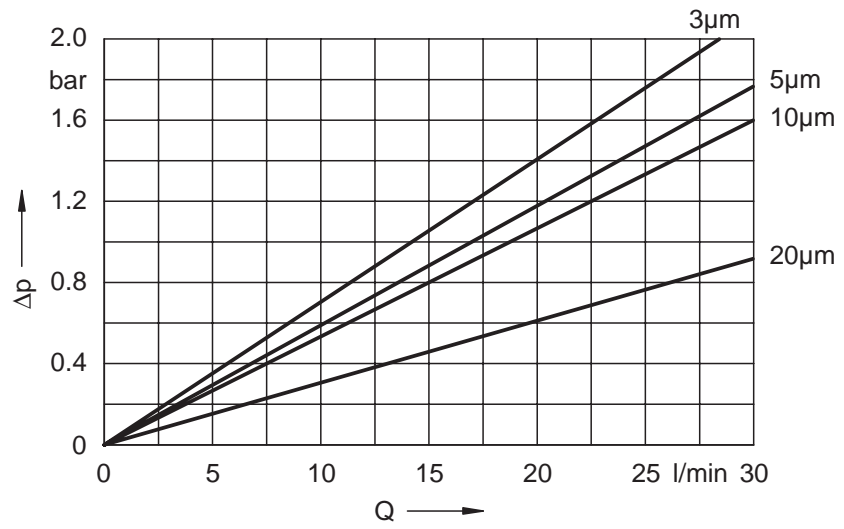

Viscosity factor  $f$

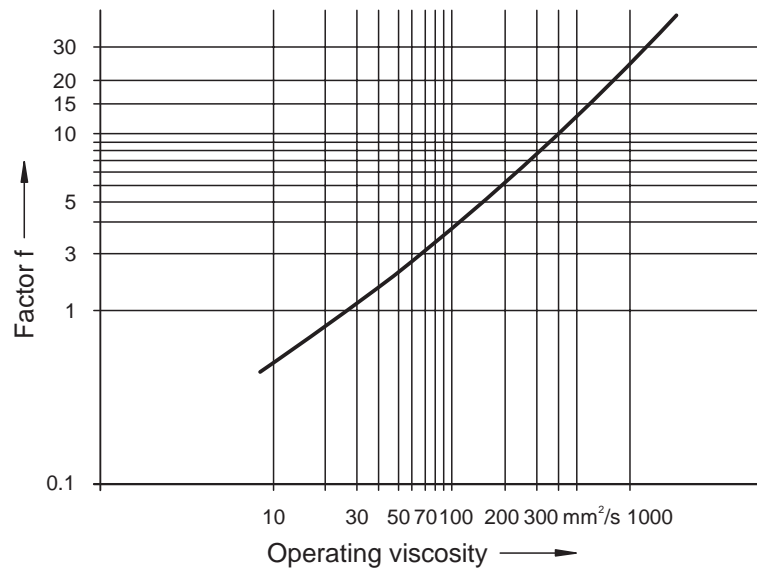



Using these tables, the following values are read off:

$$\Delta p_{\text{housing}} = 0.25 \text{ bar} \quad \Delta p_{\text{element}} = 0.8 \text{ bar} \quad f = 1.2$$

This results in a total pressure difference (pressure loss) of

$$\Delta p_{\text{total}} = 0.25 + 1.2 \cdot 0.8 \text{ bar} = 1.21 \text{ bar}$$

If the reference value for pressure filters amounts to a  $\Delta p$  of  $\sim 1$  to 1.5 bar, the filter has been correctly selected.

### Contamination indicators

It is important that the effectiveness of the filter can be checked by a contamination indicator. The contamination of a filter is measured by the drop in pressure. As the contamination increases, the pressure ahead of the filter rises. This pressure acts on a spring-loaded piston. As the pressure increases, the piston is pushed against the spring.

There are a number of different display methods. Either the piston movement is visible or else it is converted into an electrical or optical indicator by electrical contacts.

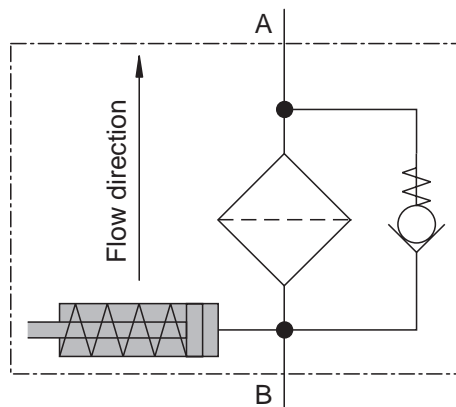

Contamination indicator

## 7.6 Coolers

In hydraulic systems, friction causes energy losses when the hydraulic fluid flows through the lines and components. This causes the hydraulic fluid to heat up. To a certain extent, this heat is given off to the environment via the oil reservoir, the lines and other components.

Operating temperature should not exceed 50° - 60 °C. Where there is a high temperature, the viscosity of the oil falls by an unacceptable amount, leading to premature ageing. It also shortens the service life of seals.

If the cooling system of the installation is not powerful enough, the cooler is generally switched on by thermostat keeping the temperature within specified limits.

The following cooling devices are available:

- Air cooler: difference in temperature of up to 25 °C possible;
- Water cooler: difference in temperature of up to 35 °C possible;
- Oil cooling by means of air fan cooler: when large quantities of heat must be dissipated.

Coolers are almost always necessary for mobile hydraulics since the reservoirs are too small to ensure adequate removal of the heat emitted from the system.

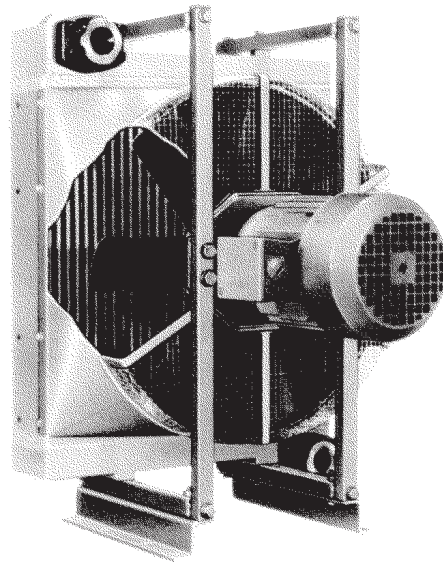

*Air cooler  
(Längerer & Reich)*

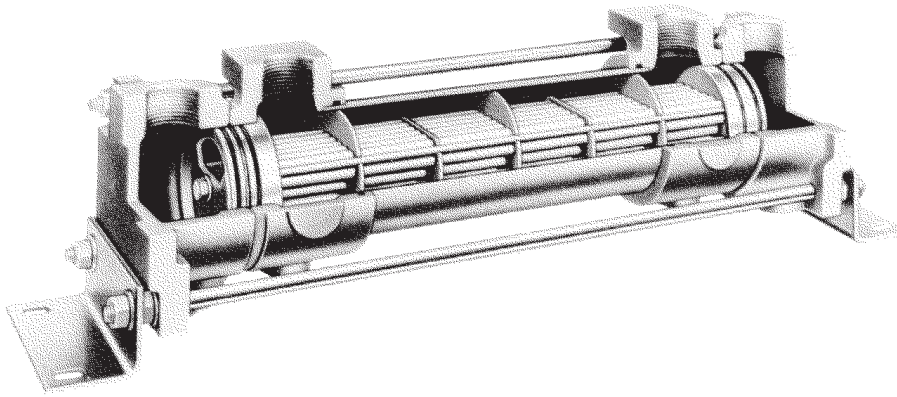

Water cooler  
(Längerer & Reich)

	Air cooler	Water cooler
Description	The hydraulic fluid flows from the return through a pipe which is cooled by a fan.	Pipes conveying oil are by-passed by coolant.
Advantages	Low running costs. Easy installation.	Larger heat losses can be diverted. No disturbing noises.
Disadvantages	Disturbing noise.	Higher operating costs. Susceptible to contamination and corrosion (coolant).

**7.7 Heaters** Heaters are often required to ensure that the optimum operating temperature is quickly attained. The aim of this is to ensure that when the system is started up, the hydraulic fluid quickly reaches the optimum viscosity. Where the viscosity is too high, the increased friction and cavitation lead to greater wear.

**Heating elements** or **flow preheaters** are used for heating and pre-heating hydraulic fluid.

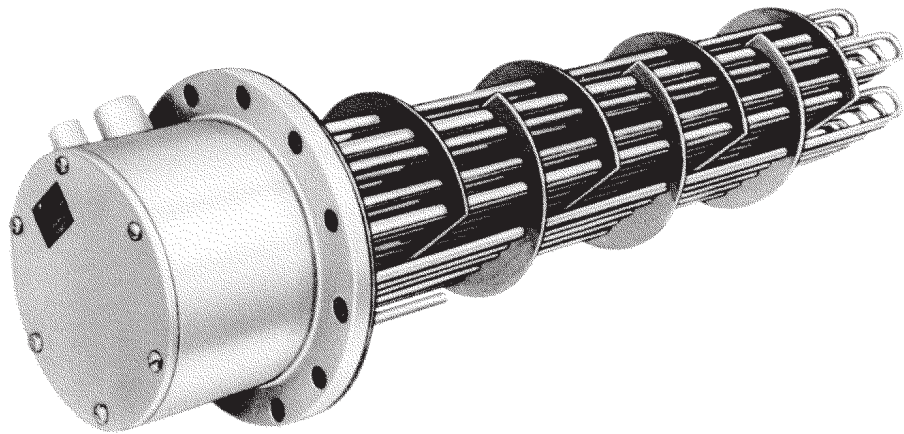

*Heating element  
(Längerer & Reich)*

#### **Estimated hydraulic fluid temperatures**

Stationary systems: 35 - 55 °C in the oil reservoir

Mobile systems: 45 - 65 °C in the oil reservoir

# Chapter 8

## Valves

In hydraulic systems, energy is transferred between the pump and consuming device along appropriate lines. In order to attain the required values – force or torque, velocity or r.p.m. – and to maintain the prescribed operating conditions for the system, valves are installed in the lines as energy control components. These valves control or regulate the pressure and the flow rate.

In addition, each valve represents a resistance.

**8.1 Nominal sizes** The nominal sizes of valves are determined by the following characteristic values:

**Nominal size NW:**

Nominal diameter in mm 4; 6; 10; 16; 20; 22; 25; 30; 32; 40; 50; 52; 63; 82; 100; 102;

**Nominal pressure NP:** (operating pressure)

Pressure in bar (Pascal) at which hydraulic devices and systems are designed to work under defined operating conditions;

Pressure stages as defined in VDMA 24312: 25; 40; 63; 100; 160; 200; 250; 315; 400; 500; 630;

**Nominal flow Q<sub>n</sub>:**

Quantity of oil (l/min) that flows through the valve at a pressure loss of  $\Delta p = 1$  bar (oil viscosity  $35 \text{ mm}^2/\text{s}$  at  $40 \text{ }^\circ\text{C}$ )

**Maximum flow Q<sub>max</sub>:**

The largest quantity of oil (l/min) which can flow through the valve with correspondingly large pressure losses.

**Viscosity range:**e.g. 20 - 230 mm<sup>2</sup>/s (cSt);**Hydraulic fluid temperature range:**

e.g. 10° - 80 °C;

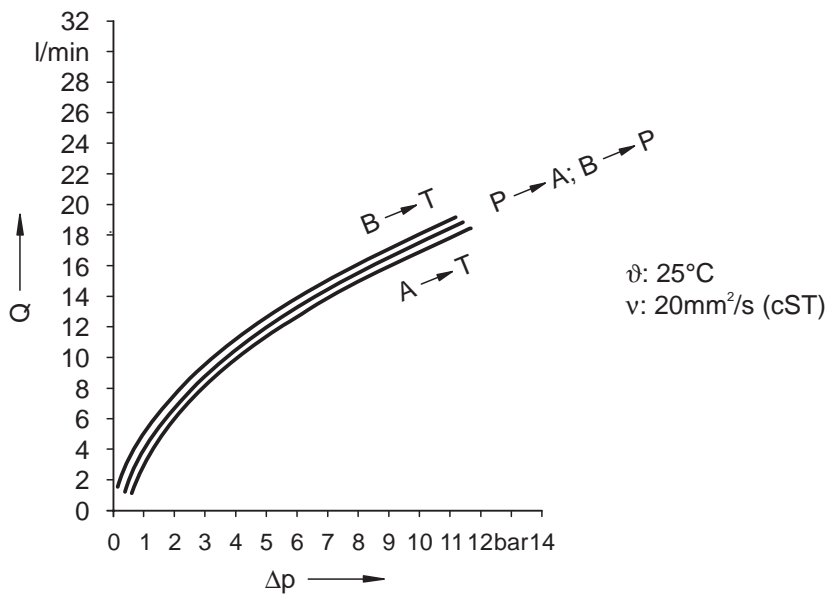
**Example**

$\Delta p$ - $\Delta Q$  characteristic curve  
for a 4/2-way valve NW 6

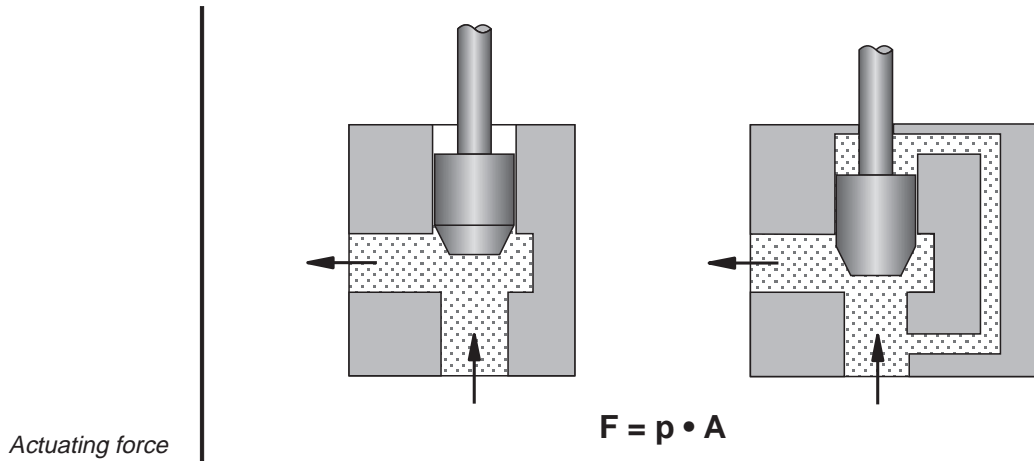

In the case of some types of poppet valve, the actuating force, which is dependent on pressure and area, may be very great. To avoid this, there must be pressure compensation at the valves (right-hand diagram).

However, in most cases, it is not possible to design poppet valves to incorporate pressure compensation. For this reason, high switching forces are required for actuation which must be overcome by lever transmission or pilot control.

The control edges of the valve are by-passed by oil causing dirt particles to be washed away (self-cleaning effect). As a result, poppet valves are relatively insensitive to dirt. However, if dirt particles are deposited on the valve seat, the valve only partially closes resulting in **cavitation**.



Various aspects are taken into consideration when classifying valves:

- Function
- Design
- Method of actuation.

A selection is made between the following types of valve based on the tasks they perform in the hydraulic system:

- Pressure valves
- Directional control valves
- Non-return valves
- Flow control valves.

Poppet valves and piston slide valves are distinguished from one another by the difference in their design. Overlapping and the geometry of the control edges are also of significance for the switching characteristics of the valve.

## 8.2 Design

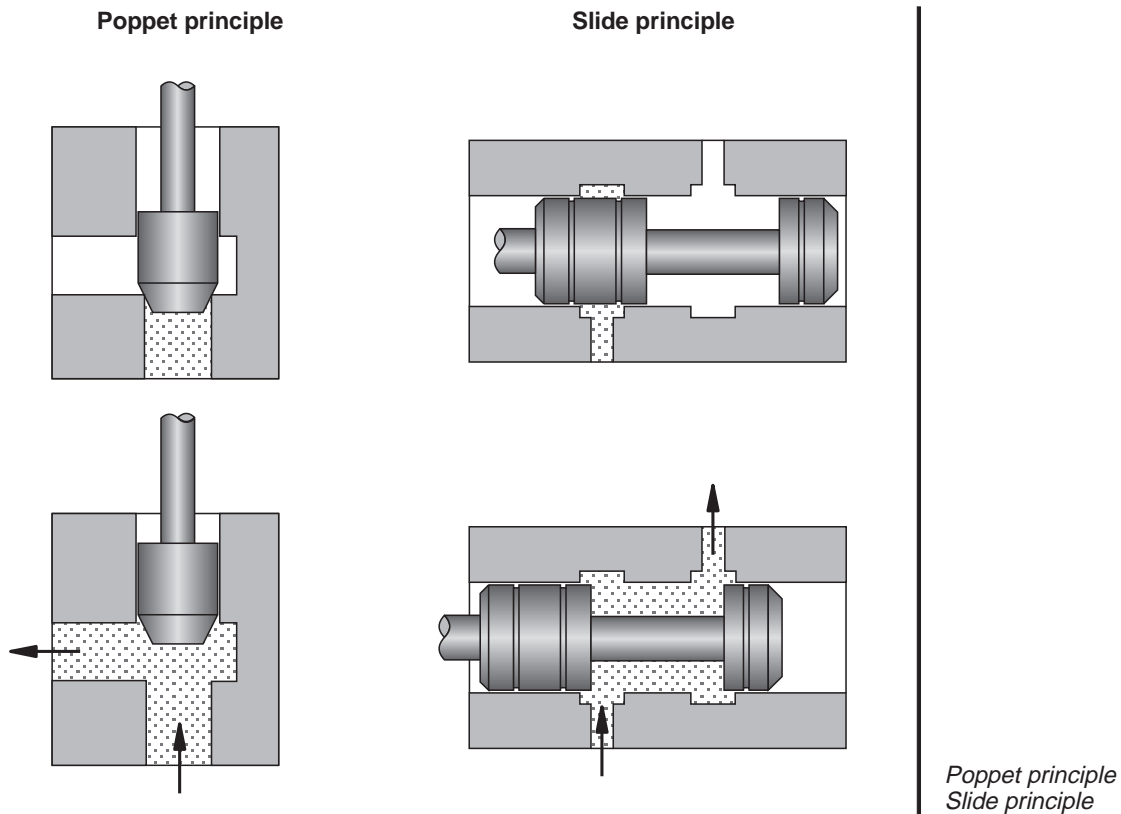

**8.3 Poppet valves**

In poppet valves a ball, cone, or occasionally a disk, is pressed against the seat area as a closing element. Valves of this design form a seal when they are closed.

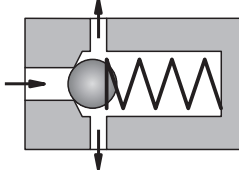
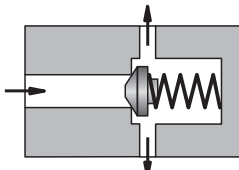
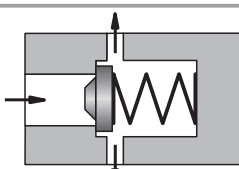
Valve type	Sectional diagram	Advantages and disadvantages/use
Ball poppet valves		simple manufacture; tendency for ball to vibrate when flow is passing through producing noise;  Non-return valves
Cone poppet valves		considerable precision is required to manufacture the cones, good sealing properties;  Directional control valves
Disk poppet valves		only small stroke area;  Shut-off valves

*Poppet valves*

According to the poppet principle, a maximum of three paths can be opened to a device by a control element. Overlapping is negative. This means that a valve which has more than three paths must be constructed from a number of control elements.

**Example** A 4/2-way valve on the poppet principle may consist internally of two 3/2-way valves.

A distinction is made between longitudinal and rotary slide valves. A rotary slide valve is made up of one or more pistons which are turned in a cylindrical bore.

**8.4 Spool valves**

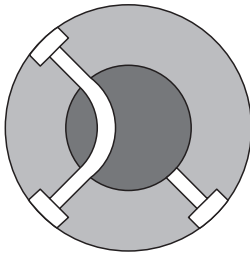

as a rule, shorter than longitudinal slide valves, when used as directional control valves.

*Rotary slide valve*

The **elongated spool valve** consists of one or more connected pistons which are axially displaced in a cylindrical drilled hole. Moving these pistons within the spool valves can open up, connect together or close any number of connection channels.

Both a 3-way pressure regulator and a 6/4-way directional control valve can be realised by this principle.

Example

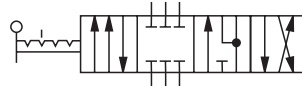
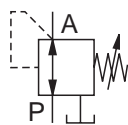

*Elongated spool valve*

To actuate elongated spool valves, it is only necessary to overcome the frictional and spring forces. Forces resulting from the existing pressure are balanced out by the opposing surfaces.

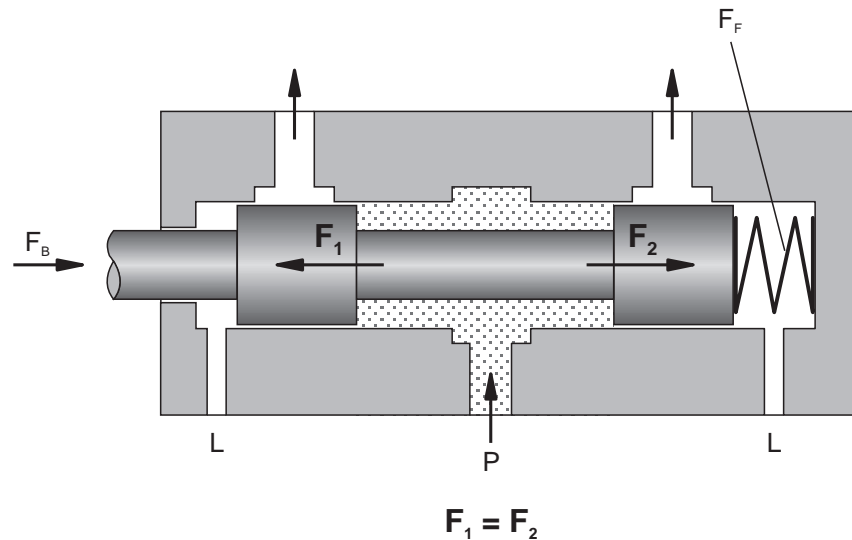

*Actuating force*

A spool must be installed with a certain amount of clearance. This clearance results in continuous leakage which causes losses in the volumetric flow rate at the valve. The spring chamber therefore must be connected with a leakage oil line. To prevent the piston being pressed against the side, the piston skirt area is provided with circular grooves.

When the piston is shifted, only fluid friction arises.

If the hydraulic oil is contaminated, dirt particles appear between the spool and bore. They act as abrasives and cause the bore to be enlarged. This results in increased leakage.

Spool principle	Poppet principle
flow leakage	good sealing
sensitive to dirt	sensitive to dirt
simple construction even in the case of multi-position valves	complicated design as multi-position valves
pressure-compensated	pressure compensation must be achieved
long actuation stroke	short actuation stroke

Comparison of valve constructions

The switching characteristics of a valve are decided by the piston overlap. A distinction is made between positive, negative and zero overlap. The type of overlap for the piston control edges can also be varied.

### 8.5 Piston overlap

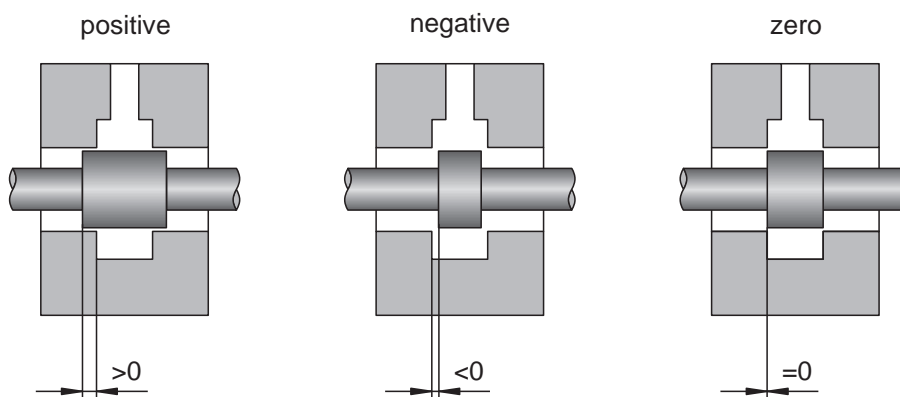

Piston overlap

In addition to determining piston clearance, the piston overlap also determines the oil leakage rate.

Overlapping is significant for all types of valve. The most favourable overlap is selected in accordance with the application:

■ **Positive switching overlap**

During the reversing procedure, all ports are briefly closed against one another; no pressure collapse (important in the case of systems with reservoirs); switching impacts resulting from pressure peaks; hard advance;

■ **Negative switching overlap**

During the reversing procedure, all ports are briefly interconnected; pressure collapses briefly (load drops down);

■ **Pressure advanced opening**

The pump is first of all connected to the power component, then the power component is discharged to the reservoir;

■ **Outlet advanced opening**

The outlet of the power component is first discharged to the reservoir before the inlet is connected to the pump;

■ **Zero overlap**

Edges meet. Important for fast switching, short switching paths.

In the case of multi-position valves, piston overlapping within a valve may vary with the application. Even switching overlaps are adapted to requirements. When repairs are necessary, it is important to ensure that the new piston has the same overlaps.

The effect of positive and negative overlap is shown below based on the example of a single-acting cylinder, triggered by a 3/2-way valve.

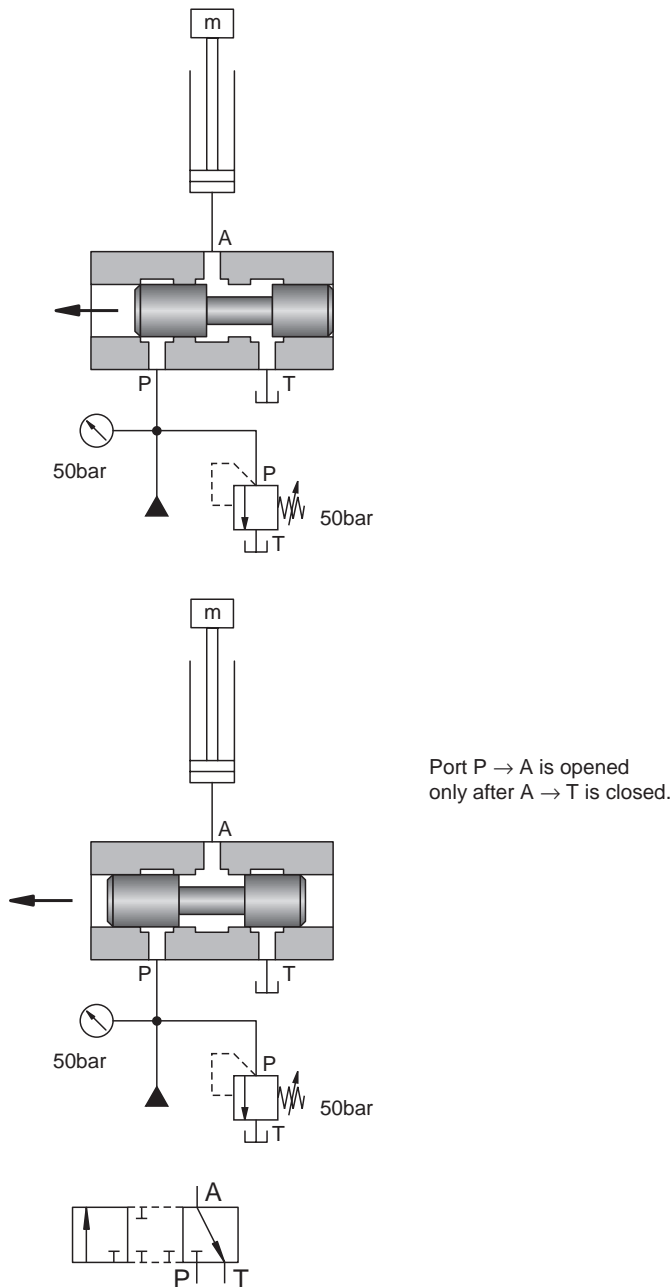

Positive switching overlap

System pressure affects the cylinder immediately, hard advance.

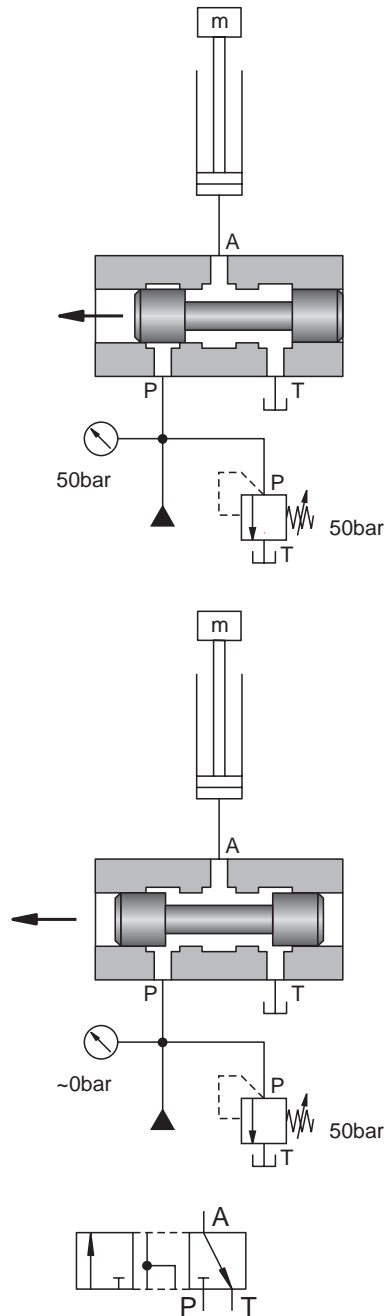

Port P → A is opened although port A → T is not closed yet. Thus, all ports are briefly interconnected.

Negative switching overlap

Pressure is reduced during the reversing procedure, gentle build-up of pressure for approach.



As with spool valves, any switching overlap can be achieved with 2/2-way poppet valves.

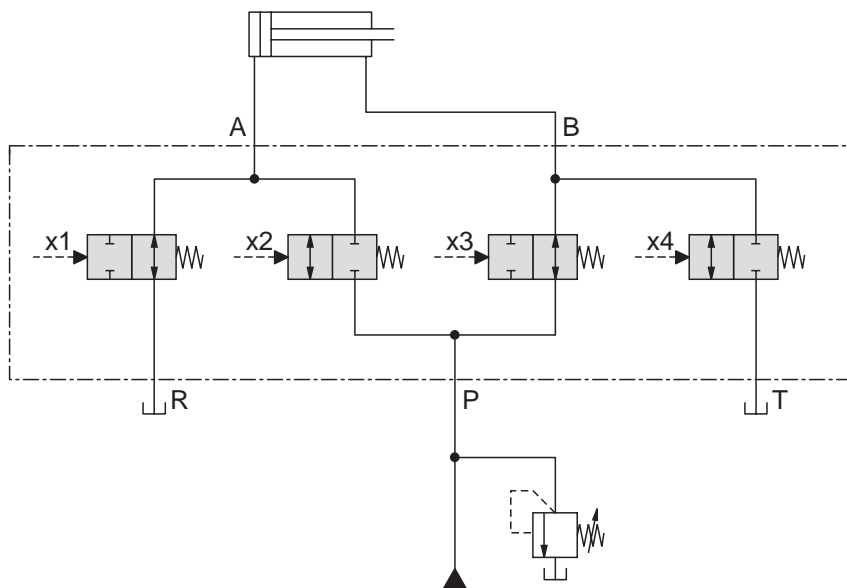

*Switching overlap  
with poppet valves*

In the case of **spool valves**, the switching overlap is decided by the geometry of the control edge and the inflexible connection of the control piston.

Where **poppet valves** are concerned, the desired switching overlap is achieved by varying response times of the various valves and can be changed, if required, by altering the switching times.

**8.6 Control edges** The **control edges** of the piston are often either sharp, **chamfered** or notched. This **profiling of the control edge** has the effect that there is gradual rather than sudden throttling of the flow on switching.

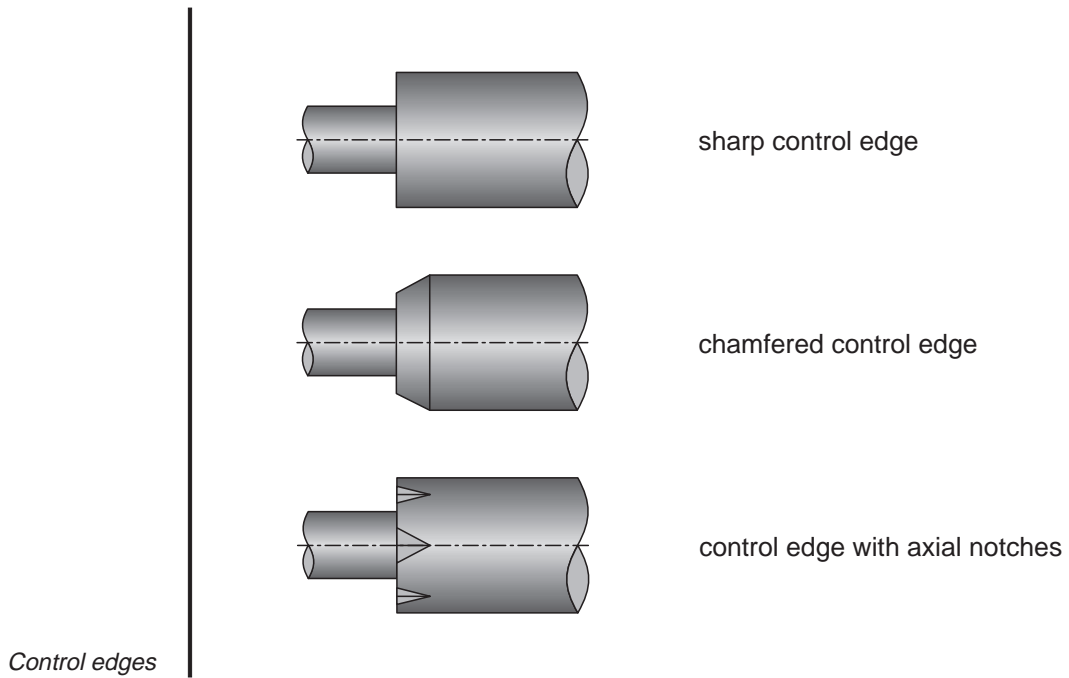

### Actuating force

The pressure in the valve causes the piston to be pressed against the bore in the housing. This results in considerable frictional forces and, consequently, high actuating forces being produced. The pressure is balanced out by annular grooves on the piston circumference. The piston is then supported on a film of oil. On actuation, only the fluid friction needs to be overcome.

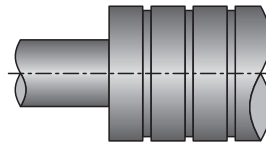

Annular grooves

There are various methods of actuation for valves. In addition, valves may also be electrically, pneumatically or hydraulically actuated.

### Port designations

There are two methods of port designation. The ports can be labelled either with the letters P, T, A, B and L or they can be labelled alphabetically.

Valves have several **switching positions**. The following rule is applied to determine which ports are interconnected and which ones are closed against each other:

- A horizontal line between the letters for the ports (e.g. P-A) means that the ports are connected together;
- An individual letter separated by a comma (e.g. P-A, T) signifies that this port (here: T) is blocked.

## Examples

P-A-B-T: all ports are interconnected.

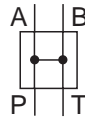

P-A-B, T: P, A and B are connected, T is blocked.

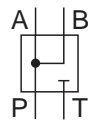

# Chapter 9

## Pressure valves

Pressure valves have the task of controlling and regulating the pressure in a hydraulic system and in parts of the system.

■ **Pressure relief valves**

The pressure in a system is set and restricted by these valves. The control pressure is sensed at the input (P) of the valve.

■ **Pressure regulators**

These valves reduce the output pressure where there is a varying higher input pressure. The control pressure is sensed at the output of the valve.

The symbols for the different pressure valves are shown below.

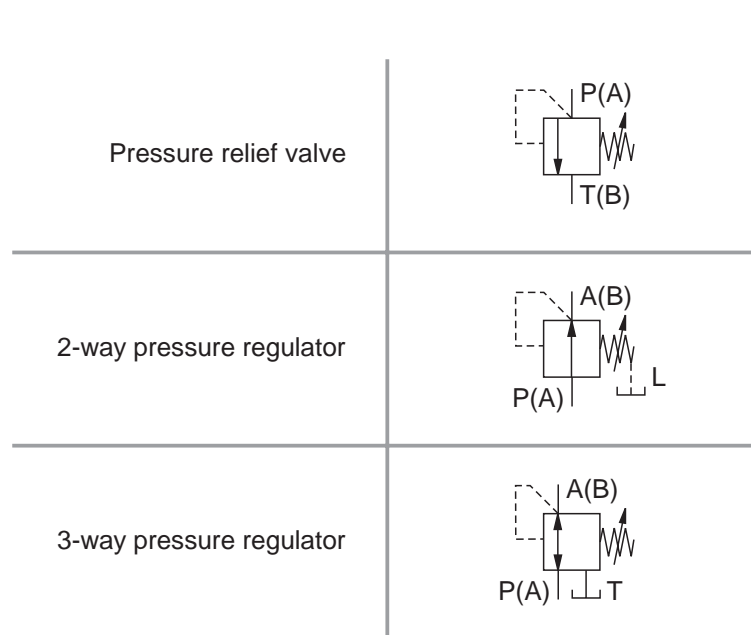

Pressure valves

Pressure relief valves are designed in the form of poppet or slide valves. In the normal position,

- a compression spring presses a sealing element onto the input port or
- a slide is pushed over the opening to the tank connection.

### 9.1 Pressure relief valves

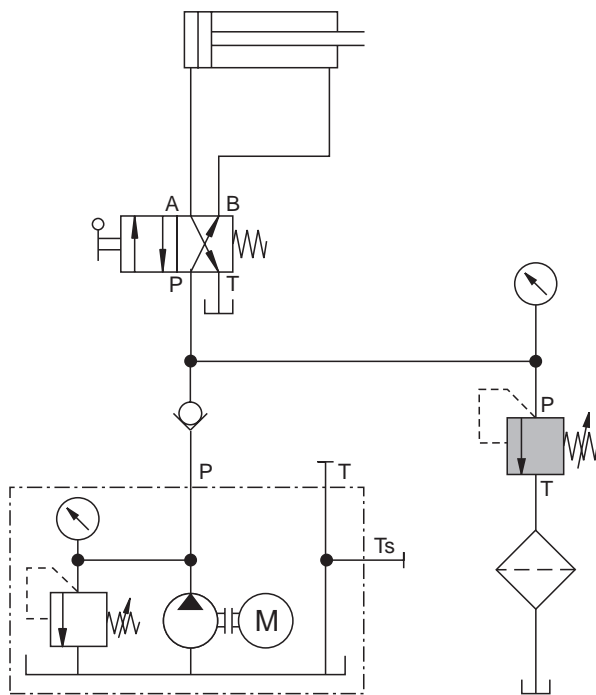

Pressure relief valves  
(circuit diagram)

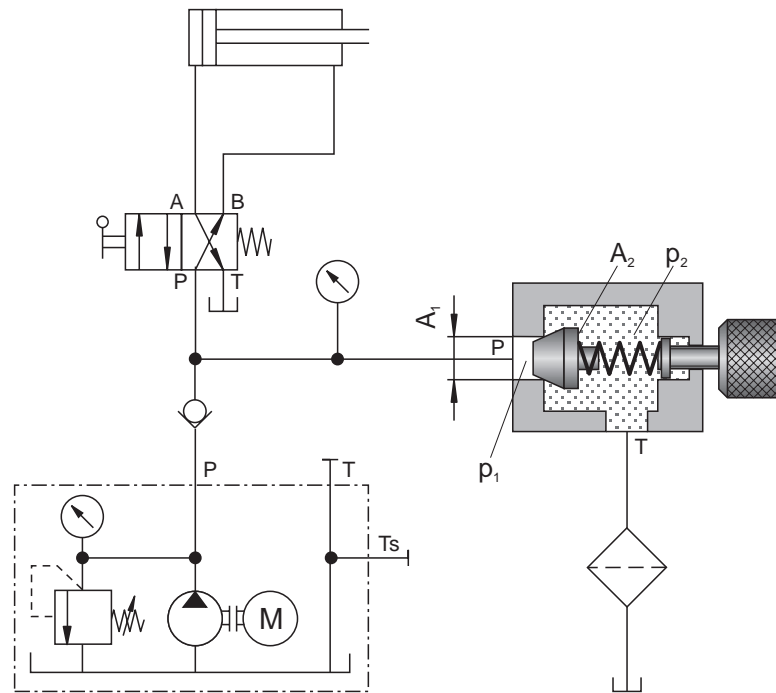

Pressure relief valves  
(sectional diagram)

Pressure relief valves operate according to the following principle:  
The input pressure ( $p$ ) acts on the surface of the sealing element and generates the force  $F = p_1 \cdot A_1$ .

The spring force with which the sealing element is pressed onto the seat is adjustable.

If the force generated by the input pressure exceeds the spring force, the valve starts to open. This causes a partial flow of fluid to the tank. If the input pressure continues to increase, the valve opens until the complete pump delivery flows to the tank.

Resistances at the output (tank line, return line filter, or similar) act on the surface  $A_2$ . The resultant force must be added to the spring force. The output side of the valve may also be pressure-compensated (see pressure relief valve with cushioning and pressure compensation).



Cushioning pistons and throttles are often installed in pressure relief valves to eliminate fluctuations in pressure. The cushioning device shown here causes:

- fast opening
- slow closing of the valve.

By these means, damage resulting from pressure surges is avoided (smooth valve operation).

Pressure knocks arise when the pump supplies the hydraulic oil to the circuit in an almost unpressurised condition and the supply port is suddenly closed by a directional control valve.

In the circuit diagram shown here, the total pump delivery flows at maximum pressure via the pressure relief valve to the tank. When the directional control valve is switched, the pressure in the direction of the cylinder decreases and the cushioned pressure relief valve closes slowly. An uncushioned valve would close suddenly and pressure peaks might occur.

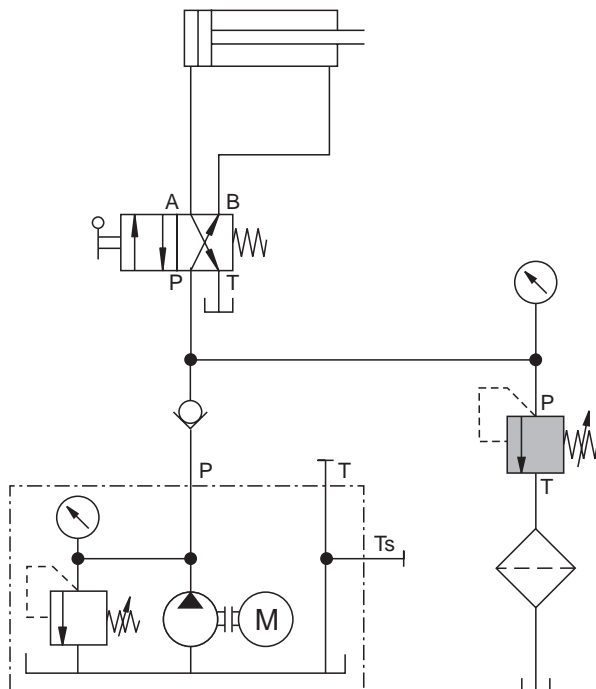

Pressure relief valve  
(circuit diagram)

Pressure relief valve  
with cushioning  
(sectional diagram)

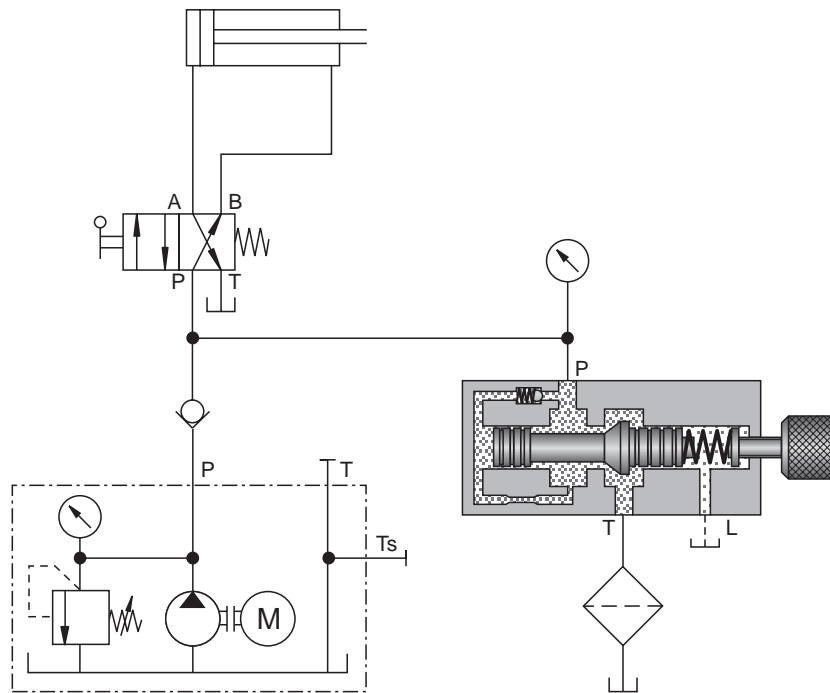

Pressure relief valves are used as:

- **Safety valves**

A pressure relief valve is termed a safety valve when it is attached to the pump, for example, to protect it from overload. The valve setting is fixed at the maximum pump pressure. It only opens in case of emergency.

- **Counter-pressure valves**

These counteract mass moments of inertia with tractive loads. The valve must be pressure-compensated and the tank connection must be loadable.

- **Brake valves**

These prevent pressure peaks, which may arise as a result of mass moments of inertia on sudden closing of the directional control valve.

- **Sequence valves (sequence valves, pressure sequence valves)**

These open the connection to other consuming devices when the set pressure is exceeded.

There are both internally and externally controlled pressure relief valves. Pressure relief valves of poppet or slide design may only be used as **sequence valves** when the pressure is compensated and loading at the tank connection has no effect on the opening characteristics.

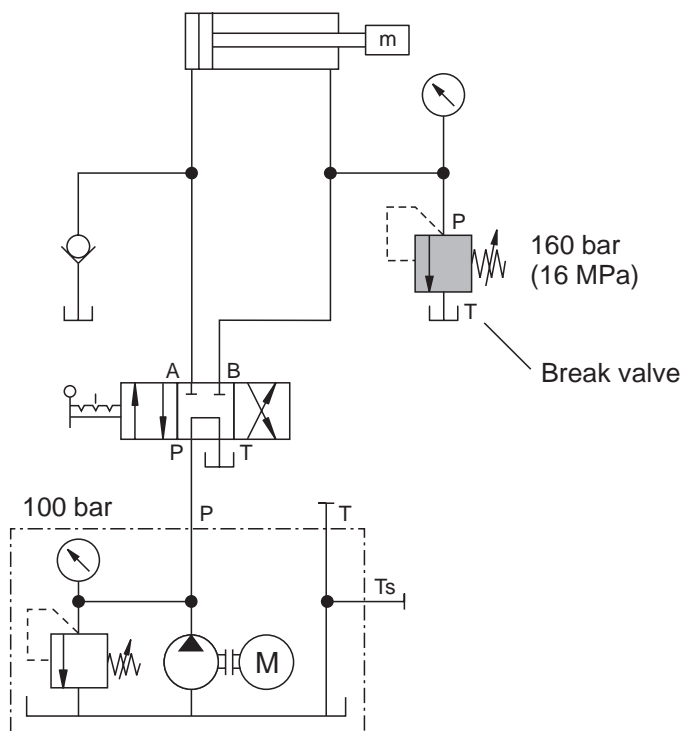

Application example:  
brake valve

The diagram below shows a cushioned pressure valve of poppet design.

*Pressure relief valve,  
internally controlled,  
cushioned*

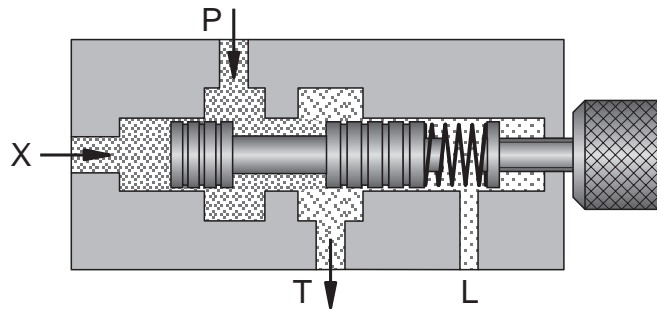
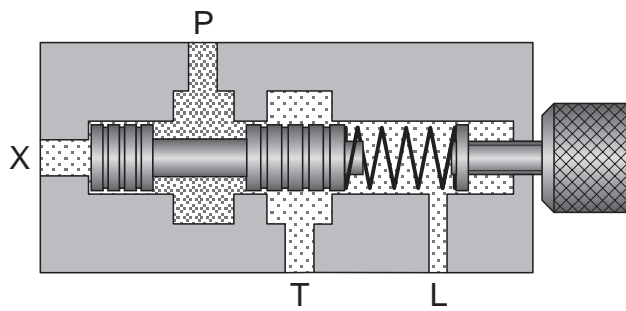
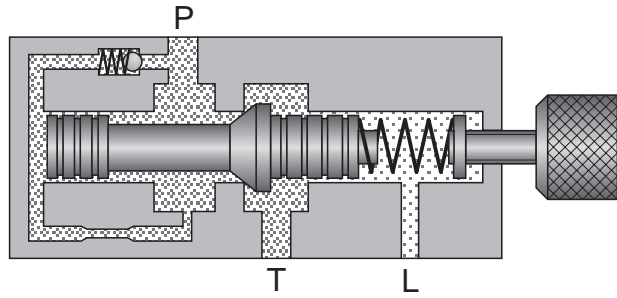

*Pressure relief valve,  
externally controlled*

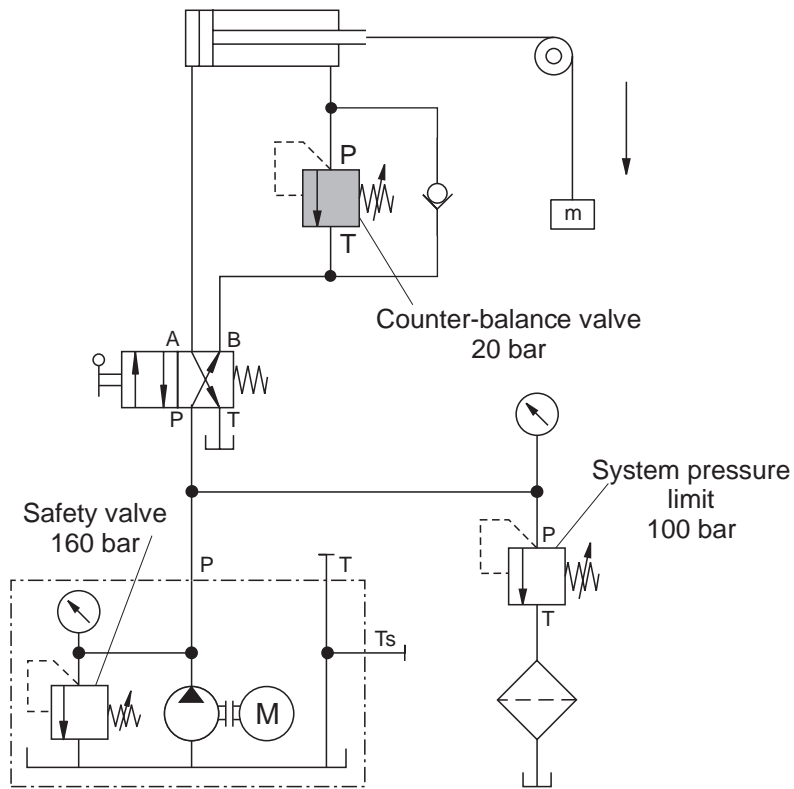

Application example:  
counter-balance valve

## 9.2 Pressure regulators

Pressure regulators reduce the input pressure to a specified output pressure.

They are only used to good effect in systems where a number of different pressures are required. To clarify this, the method of operation is explained here with the help of an example with two control circuits:

- The first control circuit operates on a hydraulic motor via a flow control valve in order to drive a roller. This roller is used to stick together multi-layer printed wiring boards.
- The second control circuit operates on a hydraulic cylinder which draws a roller towards the boards at a reduced, adjustable pressure. The roller can be lifted with a cylinder to allow the boards to be inserted (piston rod extends).

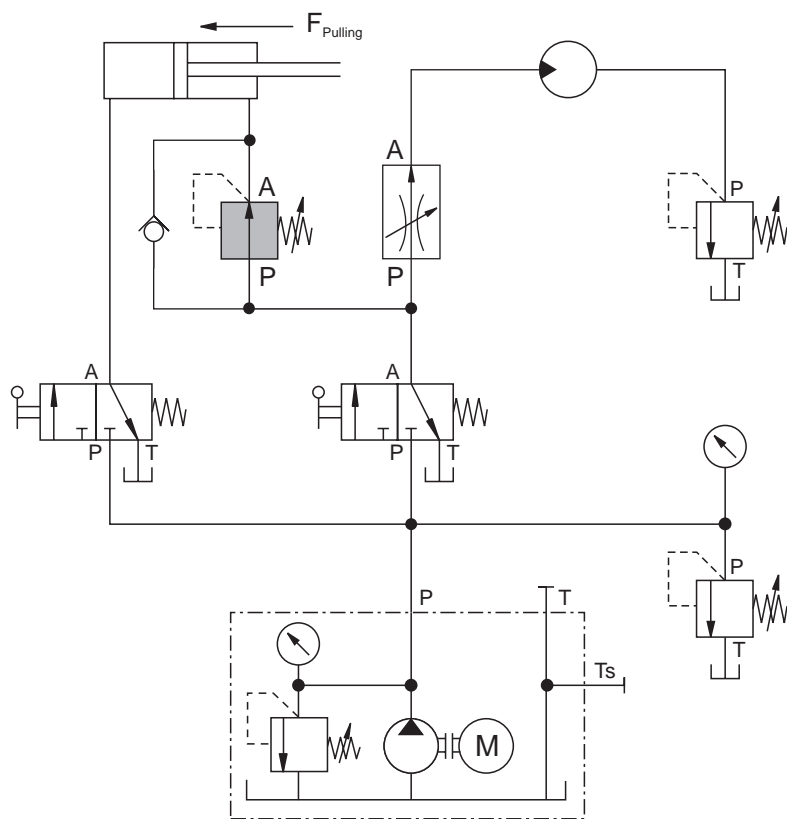

Example:  
2-way pressure regulator

The pressure regulator in the circuit diagram operates according to the following principle:

The valve is opened in the normal position. The output pressure at (A) is transmitted to the piston surface (1) via a control line (3). The resultant force is compared to the set spring force. If the force of the piston surface exceeds the set value, the valve starts to close as the valve slide moves against the spring until an equilibrium of forces exists. This causes the throttle gap to be reduced and there is a fall in pressure. If the pressure at output (A) increases once again, the piston closes completely. The pressure present in the first control circuit prevails at output (A).

Pressure regulators of poppet design open and close very quickly in the case of short strokes and may as a result flutter with fast changes in pressure; this is prevented by adding cushioning.

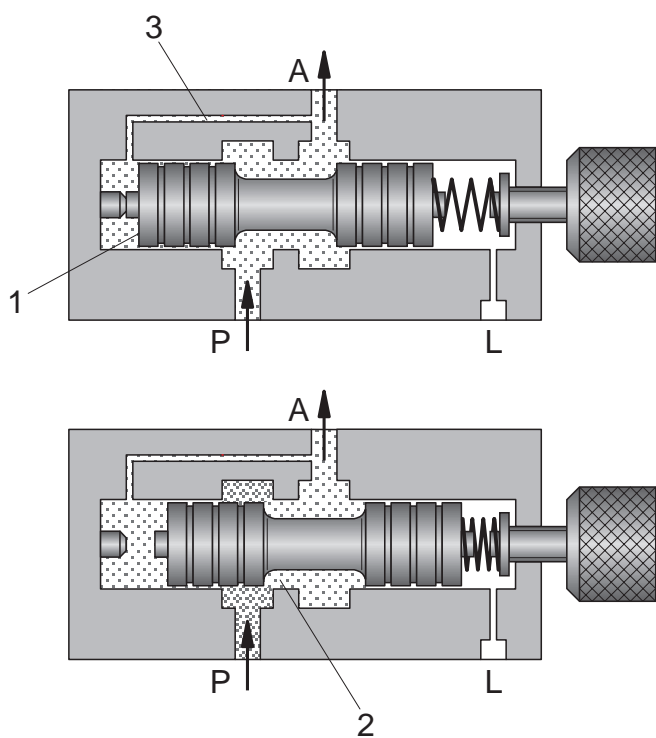

2-way pressure regulator





If the 2-way pressure regulator closes, thickening of the workpiece material causes a further pressure increase at output (A) of the pressure regulator. This increase in pressure above the set value is not desired. One method of rectifying this would be to install a pressure relief valve at the output.

The 2-way pressure regulator is rarely used in practice. Its design does not permit a reduction from a high set pressure to a low pressure.

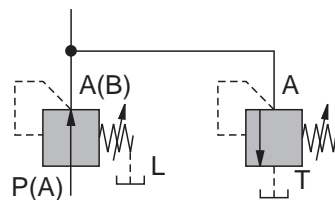

*Pressure relief valve  
to prevent increases  
in pressure*

This pressure relief valve can be set in various ways:

- PRV setting greater than that for pressure regulator;
- PRV setting equal to that of pressure regulator;
- PRV setting lower than that of pressure regulator.

These settings produce various characteristics in the pressure regulator.

Another method of reducing these increases in pressure is to use a 3-way pressure regulator.

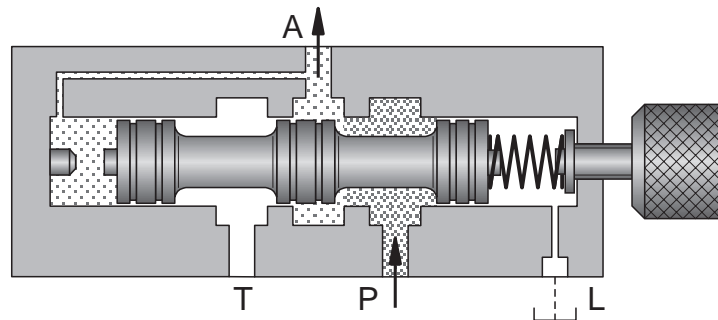

3-way pressure regulator

The method of operation of a 3-way pressure regulator is identical to that of a 2-way pressure regulator with respect to flow from P to A.

However, an increase in pressure above that which has been set at output (A) causes a further shift of the piston. The built-in pressure relief function comes into force and opens a passage from A to T.

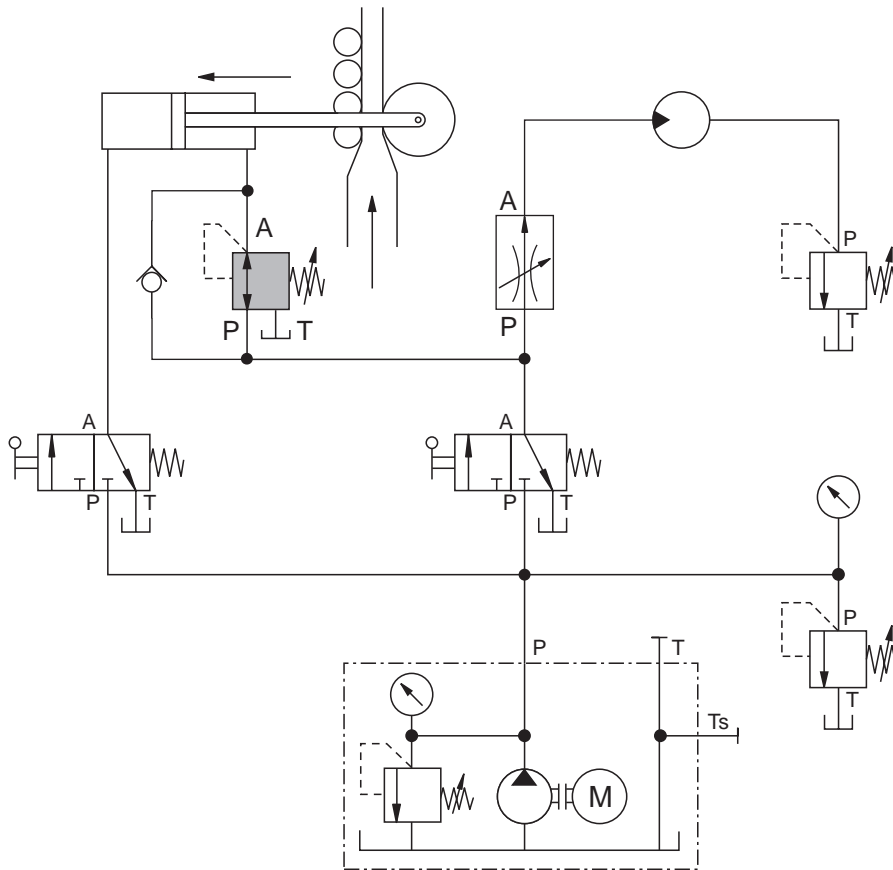

Circuit diagram for a  
3-way pressure regulator

**Note:**

In the case of the 3-way pressure regulator, the overlap forms part of the design. However, where a 2-way pressure regulator is combined with a pressure relief valve, the overlap is adjustable.

As external forces act on the cylinder in this pressure roller, a 3-way pressure regulator or a 2-way pressure regulator combined with a pressure-relief valve should be installed.

It is a good idea to use the 3-way pressure regulator with negative overlap (T opens before P closes). Where a 2-way pressure regulator is combined with a pressure-relief valve, the pressure relief valve should be set to a lower pressure than the pressure regulator.



# **Chapter 10**

## **Directional control valves**

**Directional control valves** are components which change, open or close flow paths in hydraulic systems. They are used to control the direction of motion of power components and the manner in which these stop. Directional control valves are shown as defined in DIN ISO 1219.

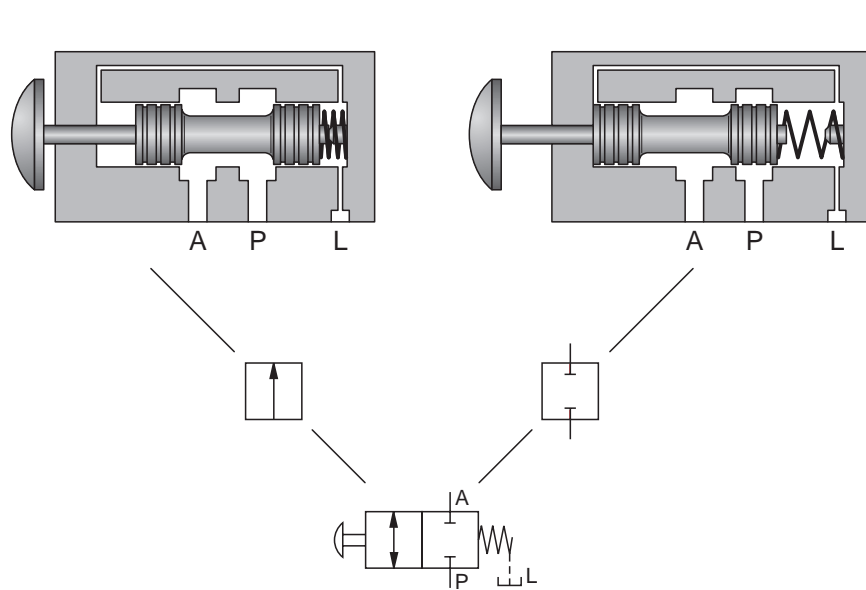

2/2-way valve

The following rules apply to the representation of directional control valves:

- Each different switching position is shown by a square.
- Flow directions are indicated by arrows.
- Blocked ports are shown by horizontal lines.
- Ports are shown in the appropriate flow direction with line arrows.
- Drain ports are drawn as a broken line and labelled (L) to distinguish them from control ports.

Symbols for directional control valves

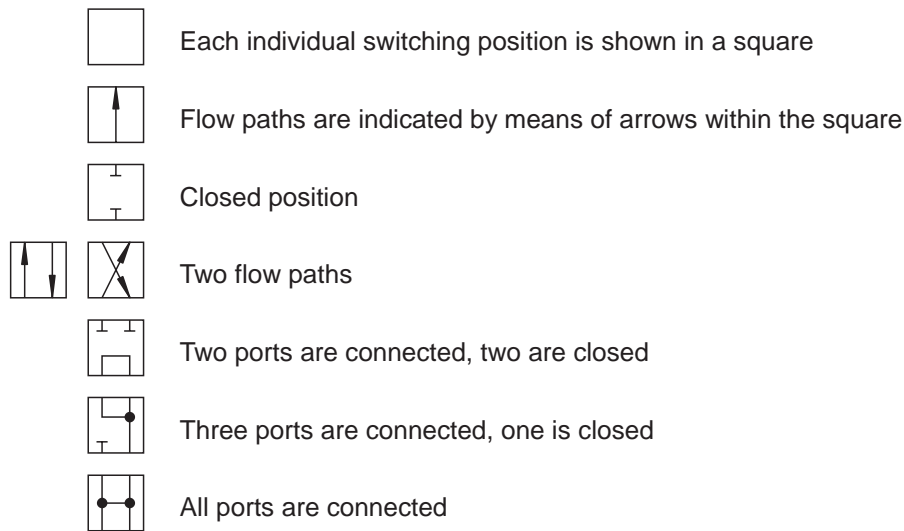

Switching positions

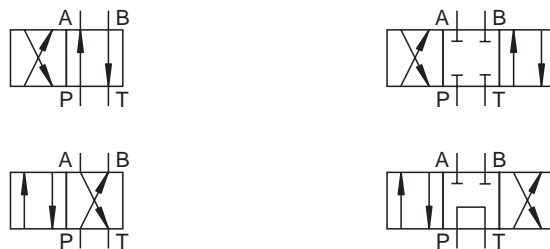

Examples: switching positions

There are two types of directional control valve: **continually operating** and **binary \*) directional control valves**.

- **Continuously operating directional control valves**

In addition to two end positions, these valves can have any number of intermediate switching positions with varying throttle effect. **Proportional and servo valves** which are discussed in the TP 700 training books are examples of this type of valve.

- **Digitally operating directional control valves**

These always have a fixed number (2, 3, 4...) of switching positions. In practice, they are known simply as **directional control valves**. They are central to **hydraulics** and form an important part of the subject matter of this book.

Directional control valves are classified as follows according to the number of ports:

- 2/2-way valve
- 3/2-way valve
- 4/2-way valve
- 5/2-way valve
- 4/3-way valve.

The diagram on the following page shows the symbols used for directional control valves. For the sake of simplicity, the actuation methods have been omitted.







Many other designs are available for use in particular fields of application.

\*) two values possible (0 or 1)

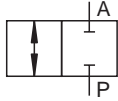
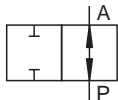
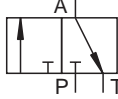
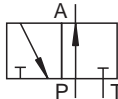
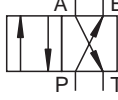
1 = output present

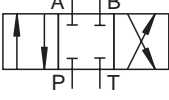
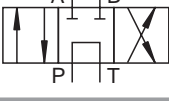
2 = output not present

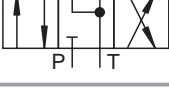

<b>2/2-WV</b>	Normal position "closed" (P, A)	
	Normal position "flow" (P → A)	
<b>3/2-WV</b>	Normal position "closed" (P, T → A)	
	Normal position "flow" (P → A, T)	
<b>4/2-WV</b>	Normal position "flow" (P → B, A → T)	
<b>5/2-WV</b>	Normal position "flow" (A → R, P → B, T)	
<b>4/3-WV</b>	Mid position "closed" (P, A, B, T)	
<b>4/3-WV</b>	Mid position "Pump re-circulating" (P → T, A, B)	
<b>4/3-WV</b>	"H" mid position (P → A → B → T)	
<b>4/3-WV</b>	Mid position "working lines de-pressurised" (P, A → B → T)	
<b>4/3-WV</b>	Mid position "By-pass" (P → A → B, T)	

Directional control valves

**10.1 2/2-way valve** The 2/2-way valve has a working port (A) and a pressure port (P) (see diagram). It controls the delivery by closing or opening the passage. The valve shown here has the following switching positions:

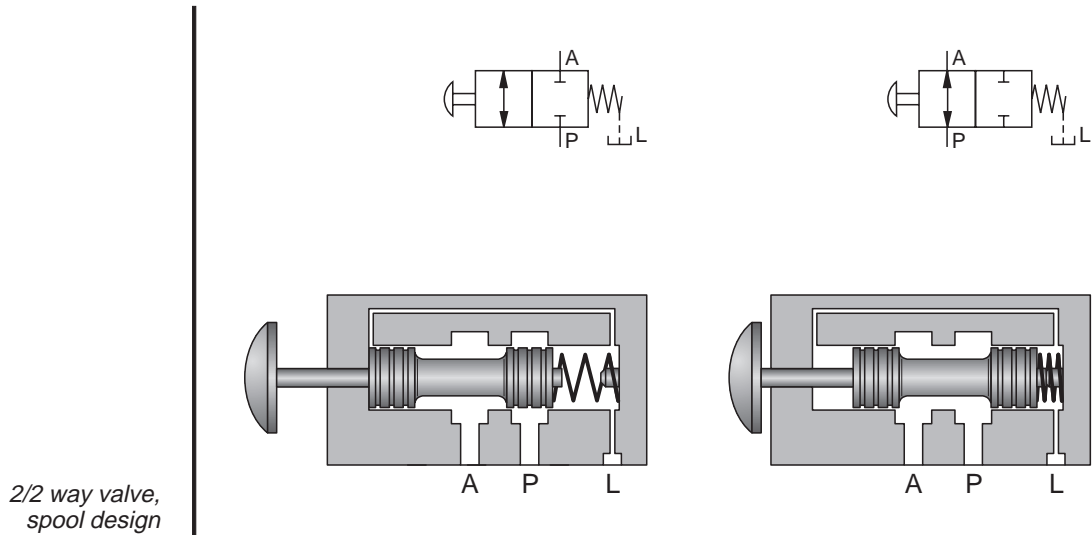

- Normal position: P to A closed;
- Actuated position: Flow from P to A

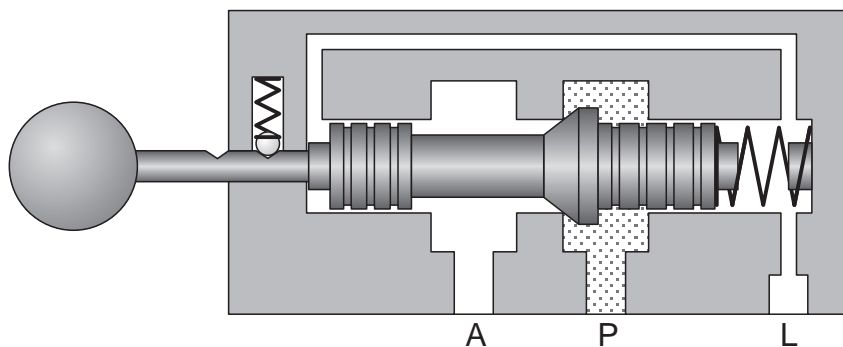

2/2-way valve,  
poppet design

Symbols for poppet valves are often drawn to include the symbol for the valve seat. This representation is not standard. This valve is also available with “flow from P to A” in the rest position.

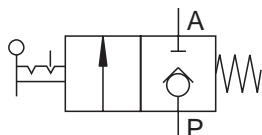

Symbol, poppet valve

Triggering a single acting cylinder (circuit diagram)

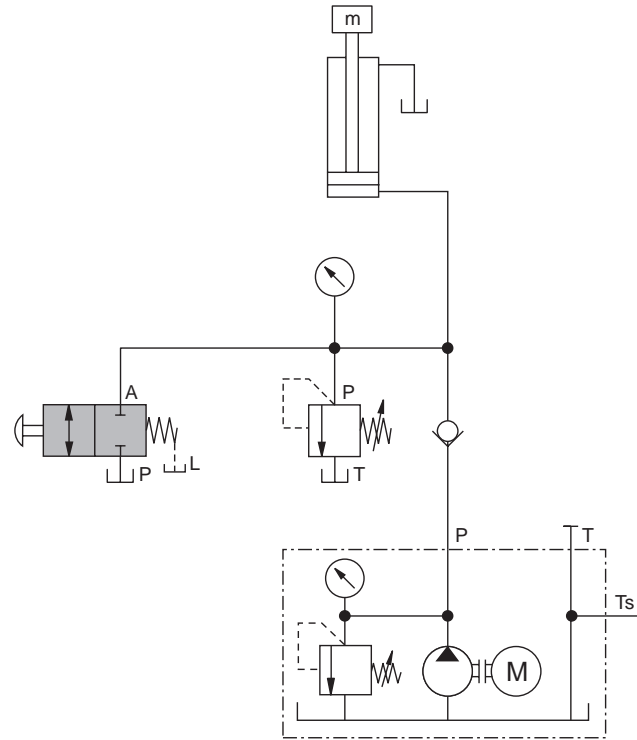

Triggering a single acting cylinder (sectional diagram)

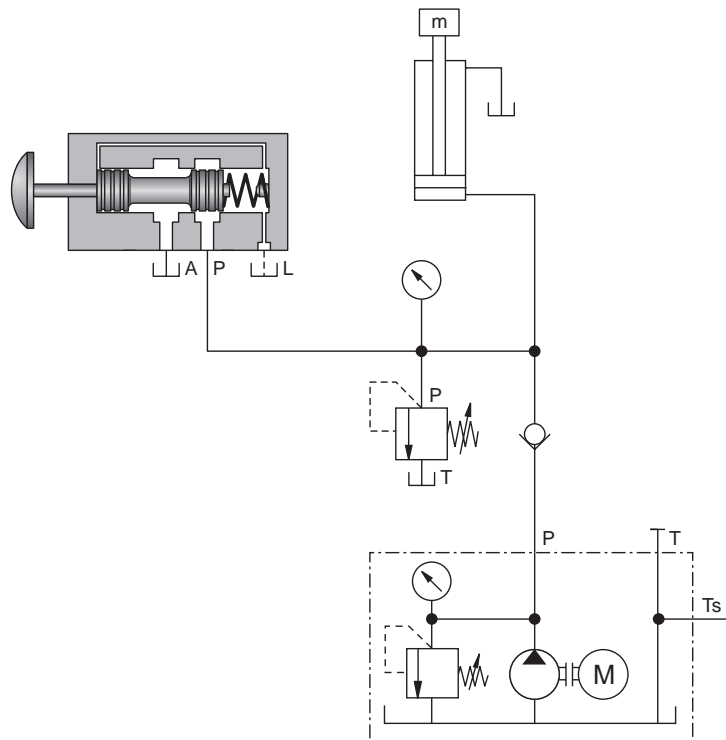

Other possible applications:

- As a by-pass, e.g. rapid traverse feed circuit, pressurizes pump by-pass;
- Switching on or off various flow or pressure valves; (pressure stage circuit)
- Triggering a motor in a single direction.

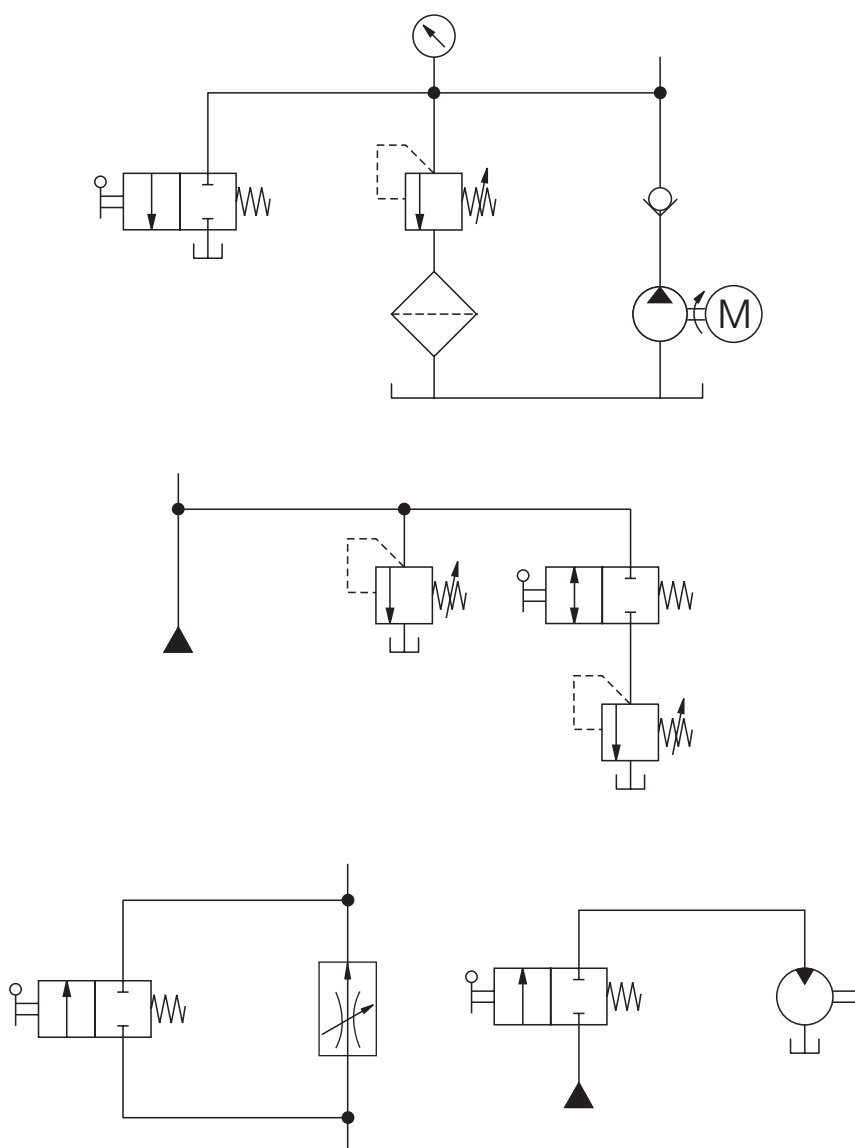

*Further application possibilities*

## 10.2 3/2-way valves

The 3/2-way valve has a working port (A), a pressure port (P) and a tank connection (T). It controls the flow rate via the following switching positions:

- Normal position: P is closed and A to T is open;
- Actuated position: Outlet T is closed, flow from P to A.

3/2-way valve can be normally open, i.e. there may be a flow from P to A.

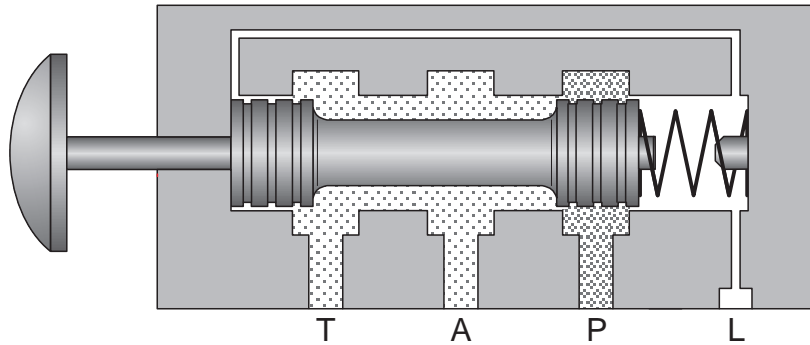

3/2-way valve

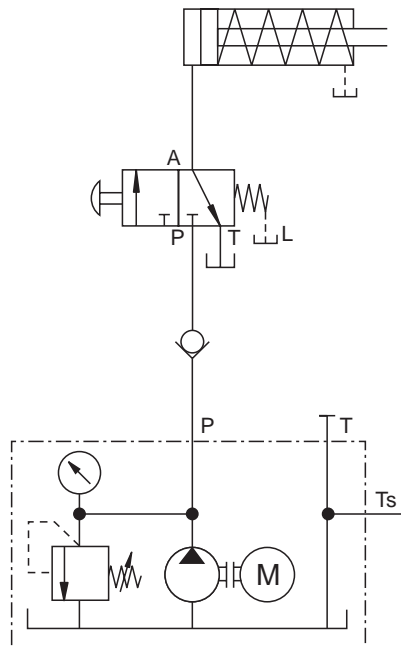

Triggering a single acting cylinder

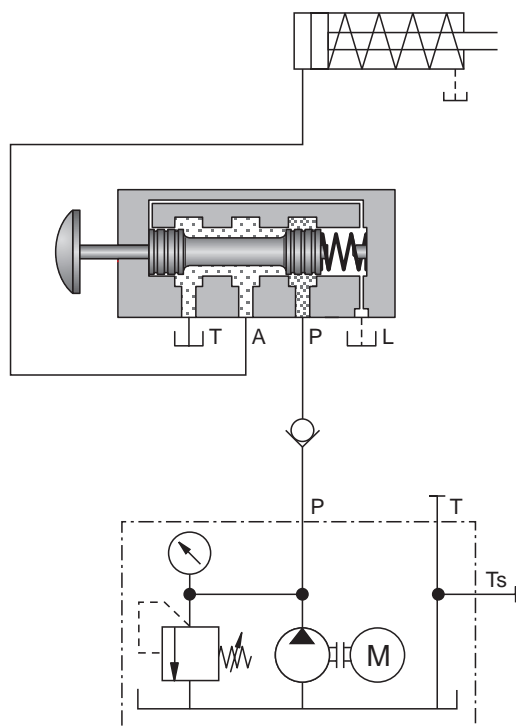

Triggering a single acting cylinder, sectional diagram

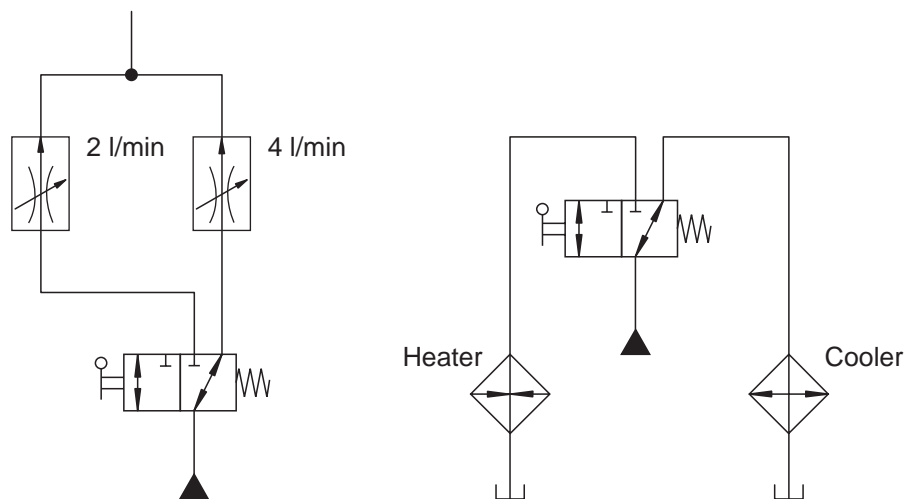

In use as shunt

- 10.3 4/2-way valves** The 4/2-way valve has two working ports (A, B), a pressure port (P) and a tank connection (T).
- Normal position: flow from P to B and from A to T;
  - Actuated position: flow from P to A and from B to T.

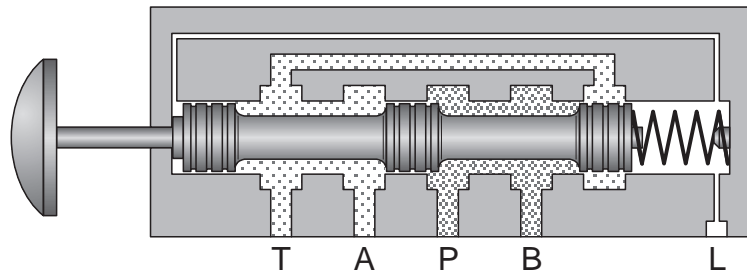

4/2-way valve with three control pistons

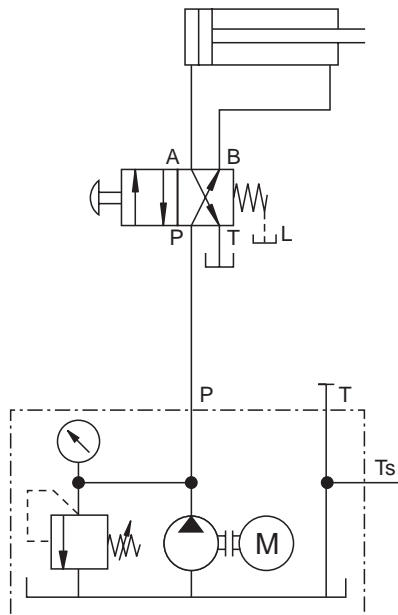

Triggering a double acting cylinder – circuit diagram



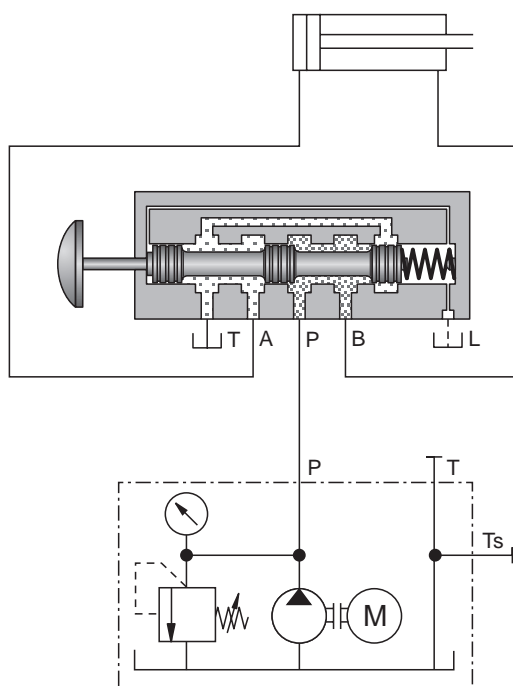

*Triggering a double acting cylinder – sectional diagram*

4/2-way valves are also constructed with just two control pistons. These valves do not require any drain ports. It should be borne in mind that tank connection T and working ports A and B are routed via the end cap of the valve in this design.

For this reason, in data sheets about these valves, a smaller maximum pressure is specified from the tank connection than for the pressure side because the pressure at this port is effective at the cover cap.

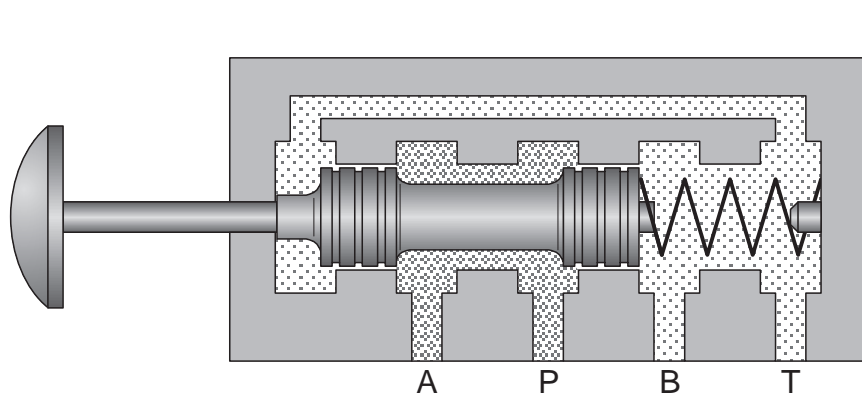

4/2-way valve with two control pistons

The simplest type of design for 4/2-way valves is that of the spool valve. 4/2-way valves of poppet design, on the other hand, are complicated as they are put together from two 3/2-way or four 2/2-way valves.

Overlapping positions Overlapping positions are an important consideration in the selection of valves. For this reason, they are often indicated in detailed representations of the symbol. As no actual switching positions are shown, the relevant box in the diagram is drawn with thinner, broken lines.

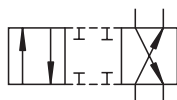

Symbol: positive switching overlap

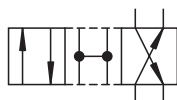

Symbol: negative switching overlap

*Overlapping position  
4/2-way valve*

Possible applications of the 4/2-way valve:

- Triggering of double-acting cylinders;
- Triggering of motors with either clockwise or anti-clockwise rotation;
- Triggering of two circuits.

A 5/2-way valve may also be used in place of the 4/2-way valve.

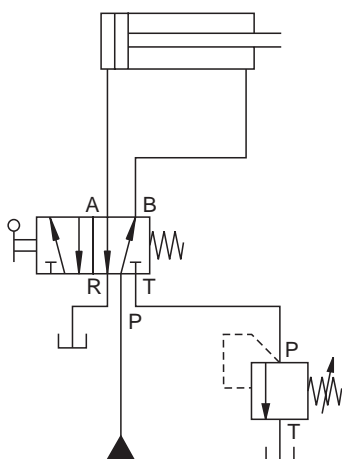

*5/2-way valve*

### 10.4 4/3-way valves

4/3-way valves constructed as spool valves are of simple construction, whilst those constructed as poppet valves are complex in design. 4/3-way valves of poppet valve design may be composed, for example, of four individual two-way valves.

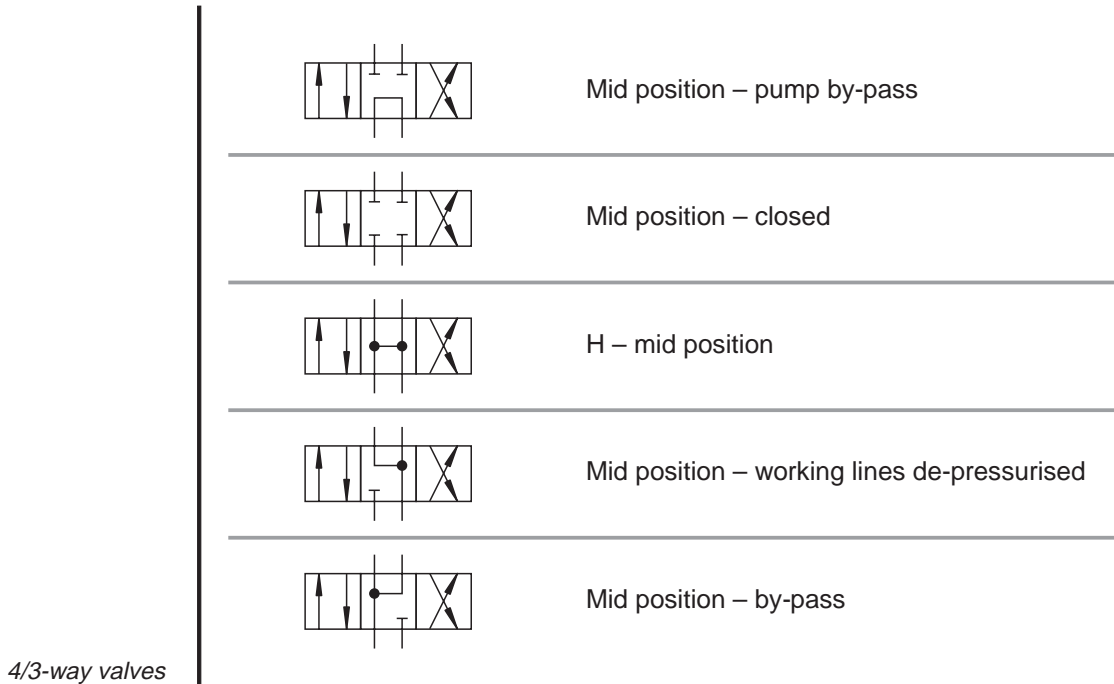

The overlapping positions are specified for 4/3-way valves:

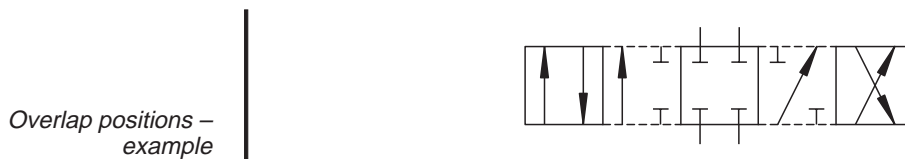

The 4/3-way valve shown here has positive overlap in the mid position. Left-hand and right-hand overlap positions are a combination of positive and negative overlap.

The mid position is decided by the control problem. Multi-position valves are also constructed as 5-way valves.

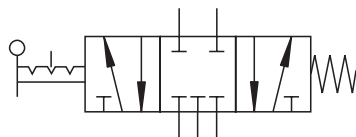

5/3-way valve

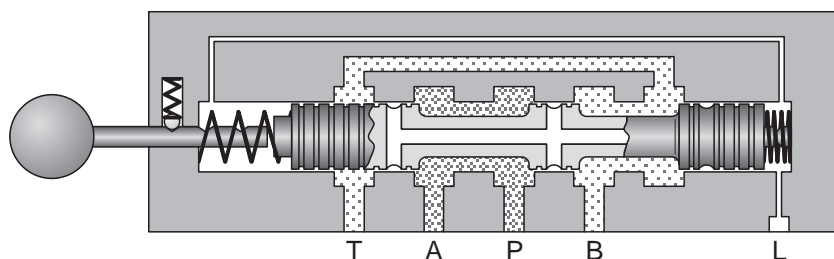
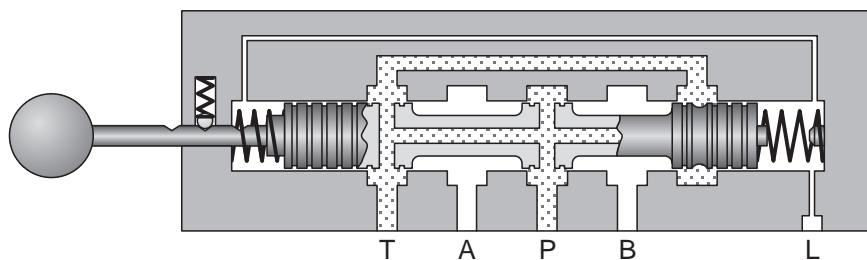
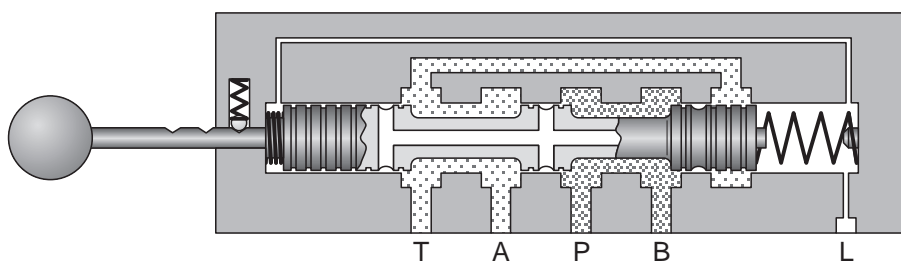
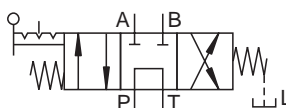

4/3-way valve with pump by-pass (re-circulating)

Only one control loop system can be driven by this valve.

*Pump by-pass*

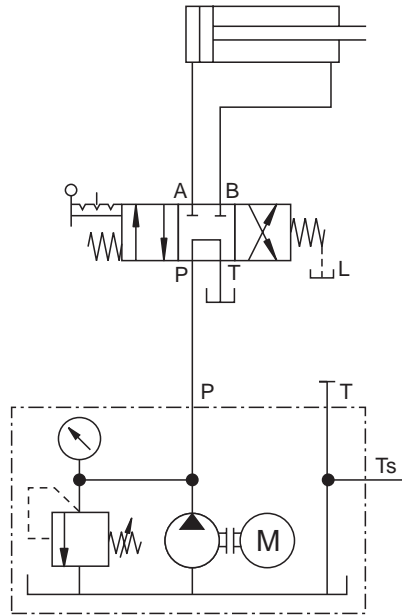

*Pump by-pass, sectional diagram*

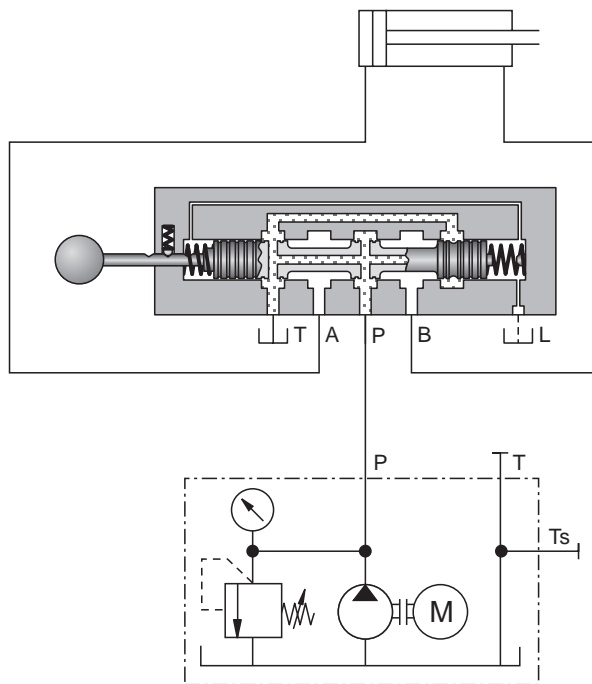

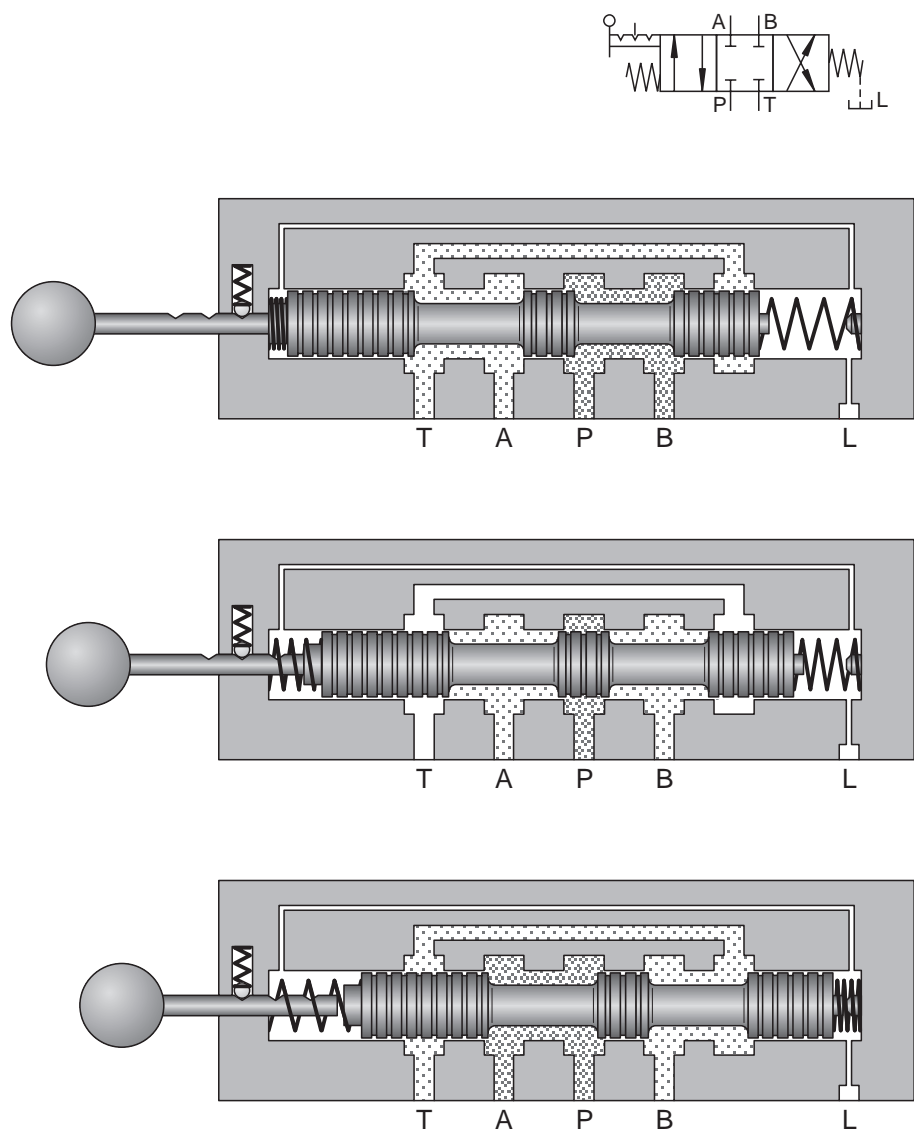

4/3-way valve,  
mid position closed

If a number of control circuits are to be powered, 4/3-way valves with mid position closed can be used to trigger individual control circuits. When an operational system is to be switched to pump by-pass, a 2/2-way valve is used.

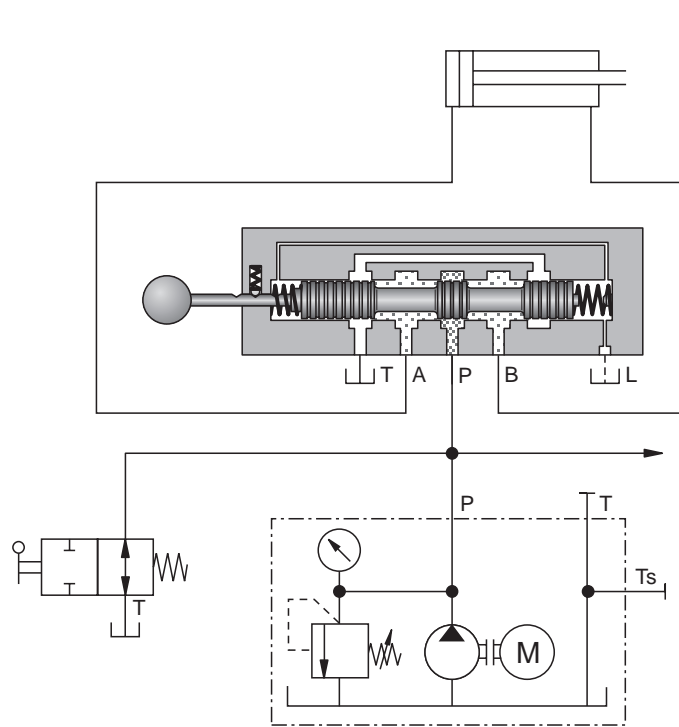

Application examples

One of the **main applications** of 4/3-way valves consists in triggering double acting cylinders and motors (stop, clockwise rotation, anticlockwise rotation).



# Chapter 11





## Non-return valves

Non-return valves block the flow in one direction and permit free flow in the other. As there must be no leaks in the closed direction, these valves are always of poppet design and are constructed according to the following **basic principle**:

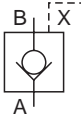

The sealing element (generally a ball or cone) is pressed against an appropriately shaped seat. The valve is opened by volumetric flow in the flow direction, the sealing element being lifted from the seat.

Non-return valves are distinguished as follows:

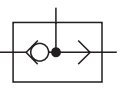
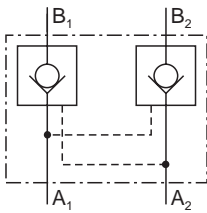
- Non-return valves (unloaded, spring-loaded)
- Lockable and unlockable non-return valves.

	Non-return valve, unloaded
	Non-return valve, spring-loaded
	Lockable non-return valve, opening of the valve is prevented by a pilot air supply or hydraulic supply
	De-lockable non-return valve, closing of the valve is prevented by a pilot air supply or hydraulic supply
	Shuttle valve
	De-lockable (pilot) double non-return valve

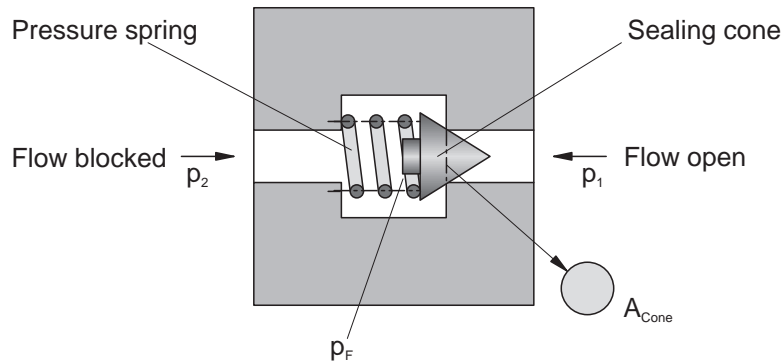
Non-return valves

Symbol: 

### 11.1 Non-return valve

*Spring loaded non-return valve*

If a pressure ( $p_1$ ) operates on the sealing cone, this is lifted from its seat releasing the flow when the valve is not spring-loaded. Counter pressure  $p_2$  must be overcome here. As the non-return valve shown here is spring-loaded, the spring force operates on the sealing cone in addition to the counter pressure  $p_2$  and flow is produced when:

$$p_1 > p_2 + p_F$$

The following equation is valid for the pressure exercised by the spring:

$$p_F = \frac{F_{spring}}{A_{cone}}$$

Possible applications The diagrams show possible applications of non-return valves.

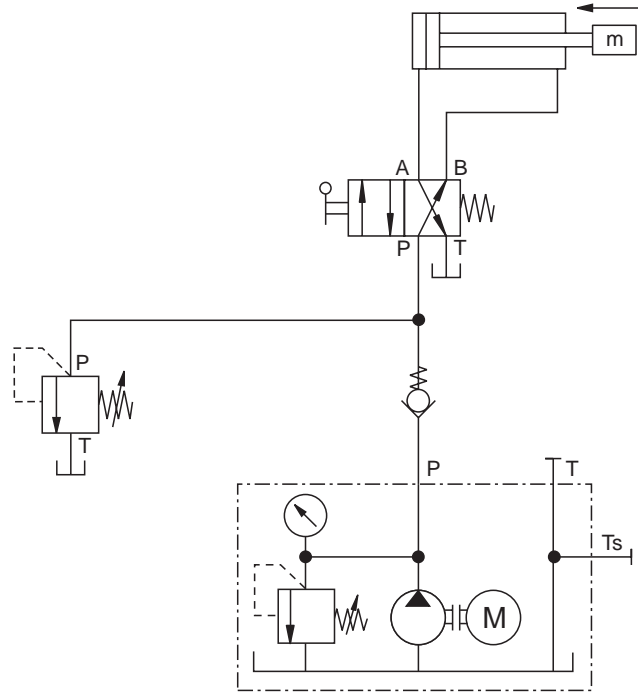

Pump protection

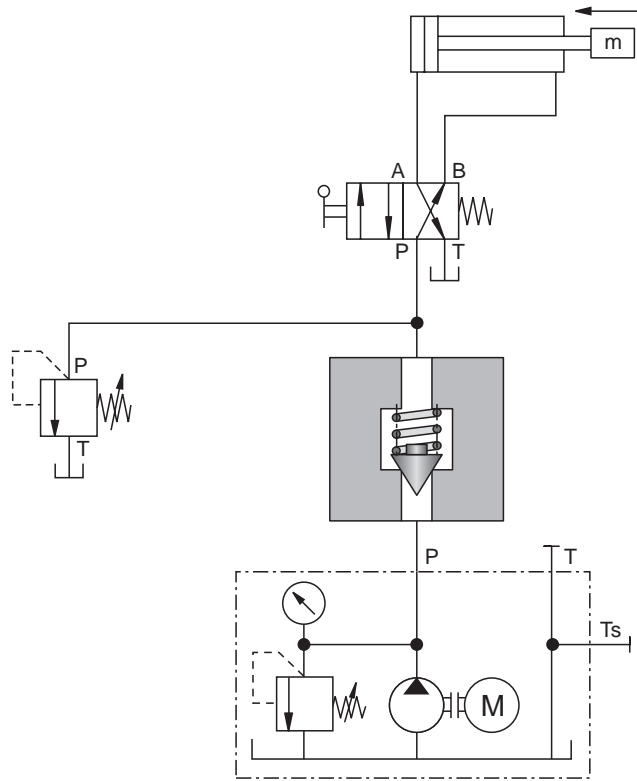
*Pump protection*

When the electric motor is switched off, the load pressure cannot drive the pump backwards. Pressure peaks which occur in the system do not affect the pump but are diverted by the pressure relief valve.



Flow valve  
only effective  
in one direction

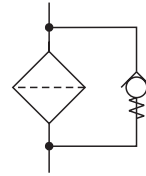

By-passing contaminated filter  
(opening pressure 0.5 – 3 bar)

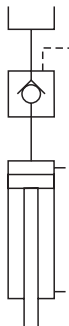

Suction retaining valve  
for a press

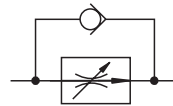

By pass  
flow regulator

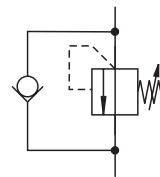

By pass  
PRV as brake valve

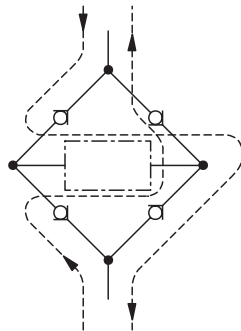

Graetz-rectifier circuit

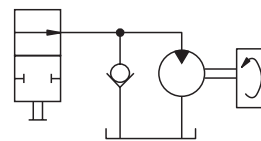

Suction retaining valve for  
a rotating mass

Applications

In piloted non-return valves, flow can be released in the closed position by pilot control of the valve poppet. This takes place according to the following principle:

Flow is possible from A to B, flow is blocked from B to A.

## 11.2 Piloted non-return valve

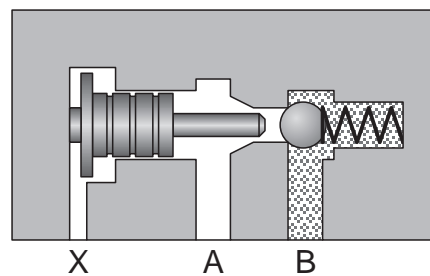

*Flow blocked from B to A*

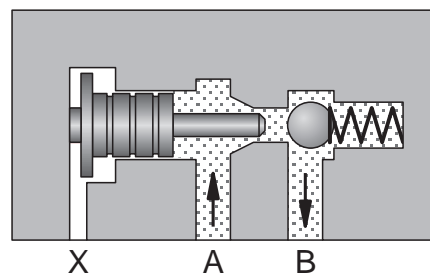

*Flow from A to B*

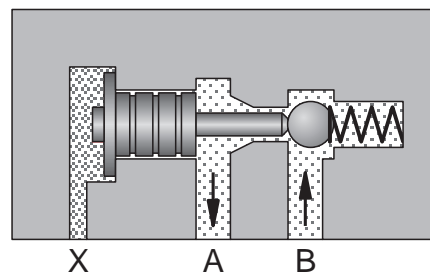

*Flow from B to A*

If the hydraulic fluid is to flow from B to A, the valve poppet with the de-locking piston must be lifted away from its seat. The de-locking piston is pressurised via control port X.

For reliable de-locking of the valve, the effective surface on the pilot piston must always be greater than the effective surface on the sealing element. The area ratio is generally 5:1. Piloted non-return valves are also made with pre-discharge.

**Method of operation** The method of operation of a piloted non-return valve in a hydraulic system is explained below using circuit diagrams:

*De-lockable non-return valve*

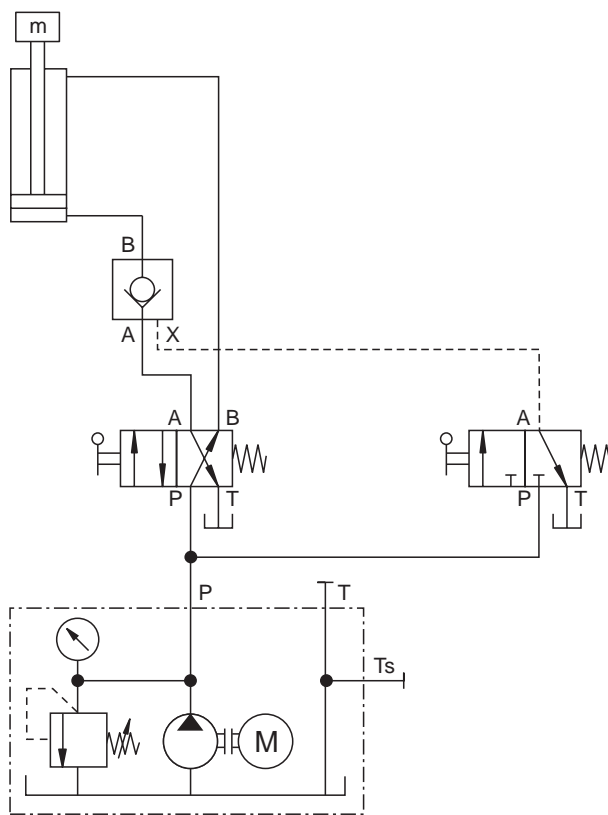

The 3/2-way valve blocks the hydraulic flow in the normal position. Oil flow is released at the 4/2-way valve on the piston rod side. The piston rod cannot retract as the non-return valve is blocked. Once the 3/2-way valve is actuated, the pilot piston is pressurised and the sealing element of the non-return valve opens. This allows the hydraulic fluid to flow away from the piston side via the 4/2-way valve to the reservoir.

When the 4/2-way valve is actuated, the hydraulic fluid flows via the non-return valve to the cylinder – the piston rod extends.



A piloted non-return valve which is raised only closes when the control oil can be discharged from the pilot port to the reservoir. For this reason, using a piloted non-return valve calls for a special mid-position of the 4/3-way valve.

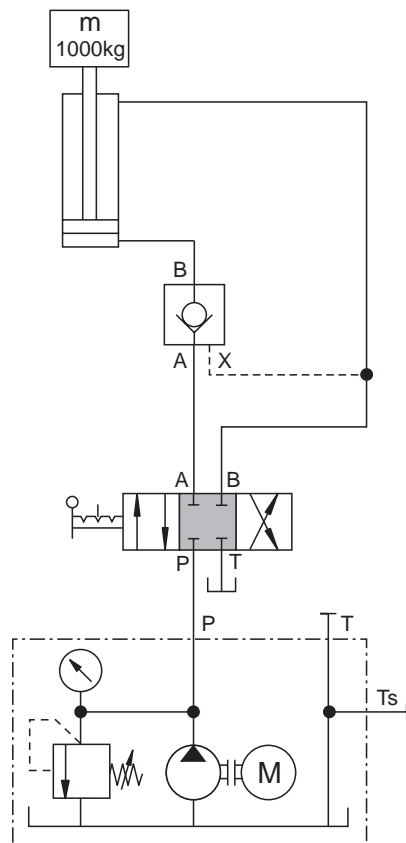

*Piloted  
non-return valve*

### Mid-position “closed”

The piloted non-return valve cannot close immediately as pressure can only escape from the closed control port X via the leakage from the directional control valve.

*Piloted  
non-return valve*

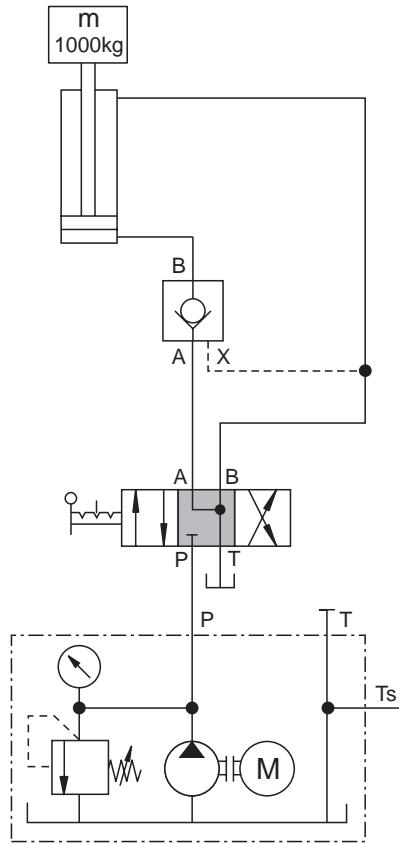

**Mid-position “Working lines de-pressurised”**

Since in this mid-position ports A and B are connected to T, and P is closed, both control port X and port B are exhausted at the non-return valve. This causes the non-return valve to close immediately.

With the piloted double non-return valve, a load can be reliably positioned above the cylinder piston even where there is internal leakage. However, this reliable positioning is only possible with supporting cylinders. Positioning by a piloted double non-return valve is not possible in the case of hanging cylinders or cylinders with through-rods.

**11.3 Piloted double non-return valve**

The diagram below shows both the simplified and complete symbols for a piloted double non-return valve and its assembly.

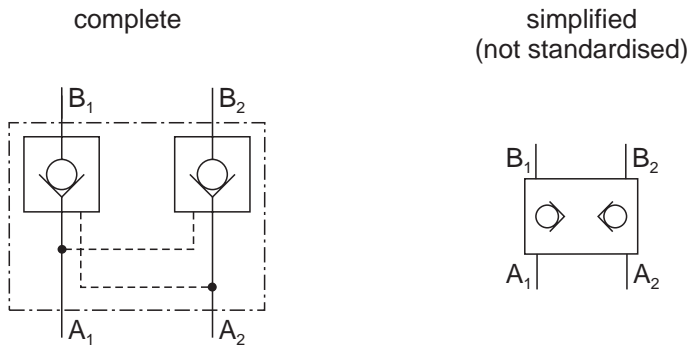

*Piloted double non-return valve, symbol*

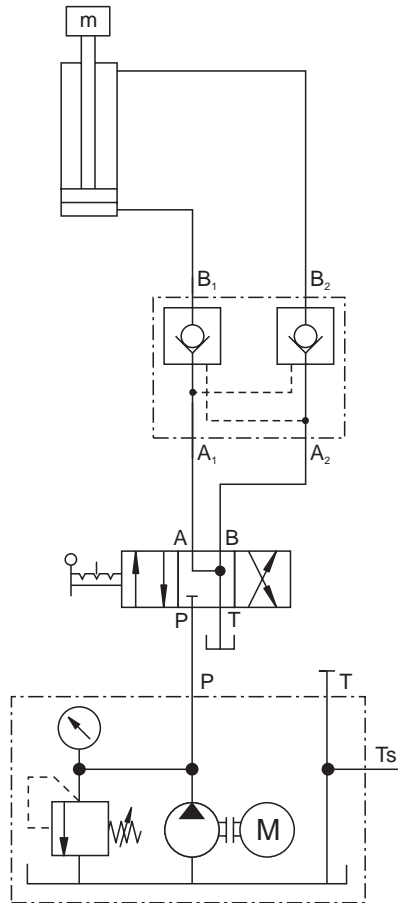

Application example

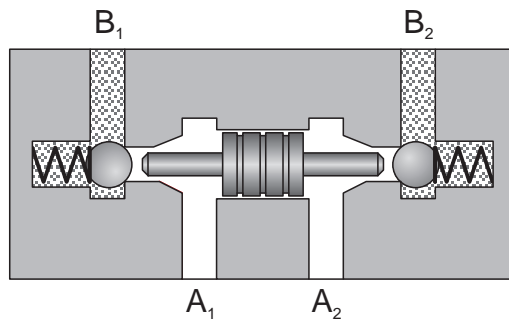

*Piloted  
double non-return valve,  
closed*

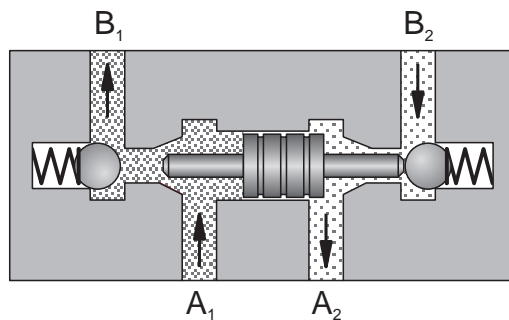

*Piloted  
double non-return valve,  
open*

The piloted double non-return valve operates according to the following principle:

Free flow is possible either in the flow direction from A<sub>1</sub> to B<sub>1</sub> or from A<sub>2</sub> to B<sub>2</sub>, flow is blocked either from B<sub>1</sub> to A<sub>1</sub> or from B<sub>2</sub> to A<sub>2</sub>.

If flow passes through the valve from A<sub>1</sub> to B<sub>1</sub>, the control piston is shifted to the right and the valve poppet is lifted from its seat. By these means, flow is opened from B<sub>2</sub> to A<sub>2</sub> (the valve operates in a corresponding manner where there is flow from A<sub>2</sub> to B<sub>2</sub>).



# Chapter 12

## Flow control valves

Flow control valves are used to reduce the speed of a cylinder or the r.p.m. of a motor. Since both values are dependent on the flow rate, this must be reduced. However, fixed displacement pumps supply a uniform flow rate. Reduction in the rate of flow supplied to the drive element is achieved according to the following principle:

A reduction in the flow cross-section in the flow control valve causes an increase in pressure ahead of this. This pressure causes the pressure relief valve to open and, consequently, results in a division of the flow rate. This division of the flow rate causes the flow volume required for the r.p.m. or speed to flow to the power component and the excess delivery to be discharged via the pressure relief valve. This results in a considerable energy loss.

In order to save energy, adjustable pumps can be used. In this case, the increase in pressure acts on the adjustable pump device.

On the basis of their controlling or regulating function, flow control valves are classified as either:

- flow control valves or
- flow regulating valves.

Examples of flow control valves as restrictors and orifice valves:

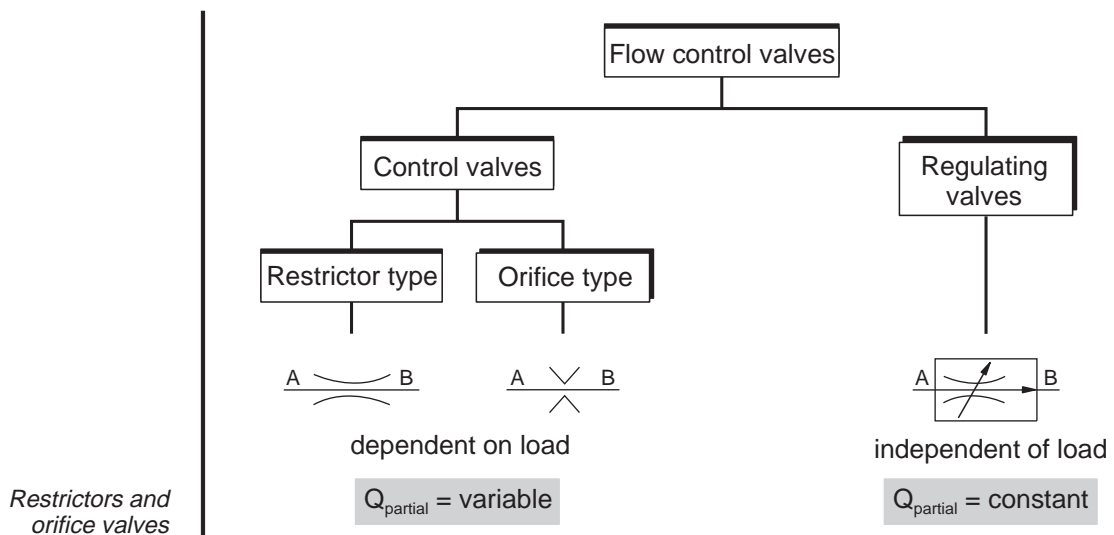



Restrictors and orifice valves represent a flow resistance. This resistance is dependent on the flow cross-section and its geometric form and on the viscosity of the liquid. When hydraulic fluid is passed through the flow resistor, there is a fall in pressure as a result of friction and of an increase in the flow velocity. The part of the pressure drop caused by friction can be considerably reduced by changing the orifice shape. In order to obtain the required resistance using an orifice, turbulence must be achieved by increasing the flow velocity (smaller cross-section than that of a corresponding restrictor). In this way, the resistance of the orifice is determined by the turbulence and becomes **independent of viscosity**. For this reason, orifice valves are used in cases where independence from temperature and, therefore, from viscosity is required, e.g. in flow gauges.

## 12.1 Restrictors and orifice valves

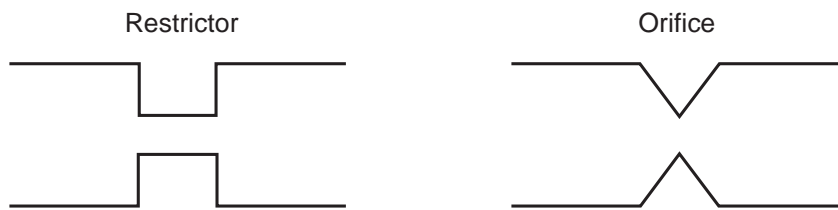

Restrictor and orifice

In many control systems, on the other hand, a specified high fall in pressure is a requirement. In such cases, restrictors are used.

Restrictors and orifice valves control the flow rate together with a pressure relief valve. The valve resistance causes pressure to build up ahead of these valves.

The pressure relief valve opens when the resistance of the restrictor is greater than the set opening pressure at the pressure relief valve. As a result, the flow is divided. Part of the pump delivery flows to the consuming device, the other part is discharged under maximum pressure via the pressure relief valve (high power loss). The partial flow passing through the throttling point is dependent on the pressure difference  $\Delta p$ . The interrelationship between  $\Delta p$  and the flow  $Q_{\text{consuming device}}$  corresponds to:

$$\Delta p \sim Q_{\text{consuming device}}^2$$

The inlet pressure to the valve is kept at a constant level by the pressure relief valve. The pressure difference  $\Delta p$  is changed by altering the load coming from the consuming device. The result of this is that there is a change in the rate of flow to the consuming device, i.e.:

The operation of restrictors is flow-dependent.

Consequently, they are not suitable for adjusting a constant flow rate in the case of a changeable load.

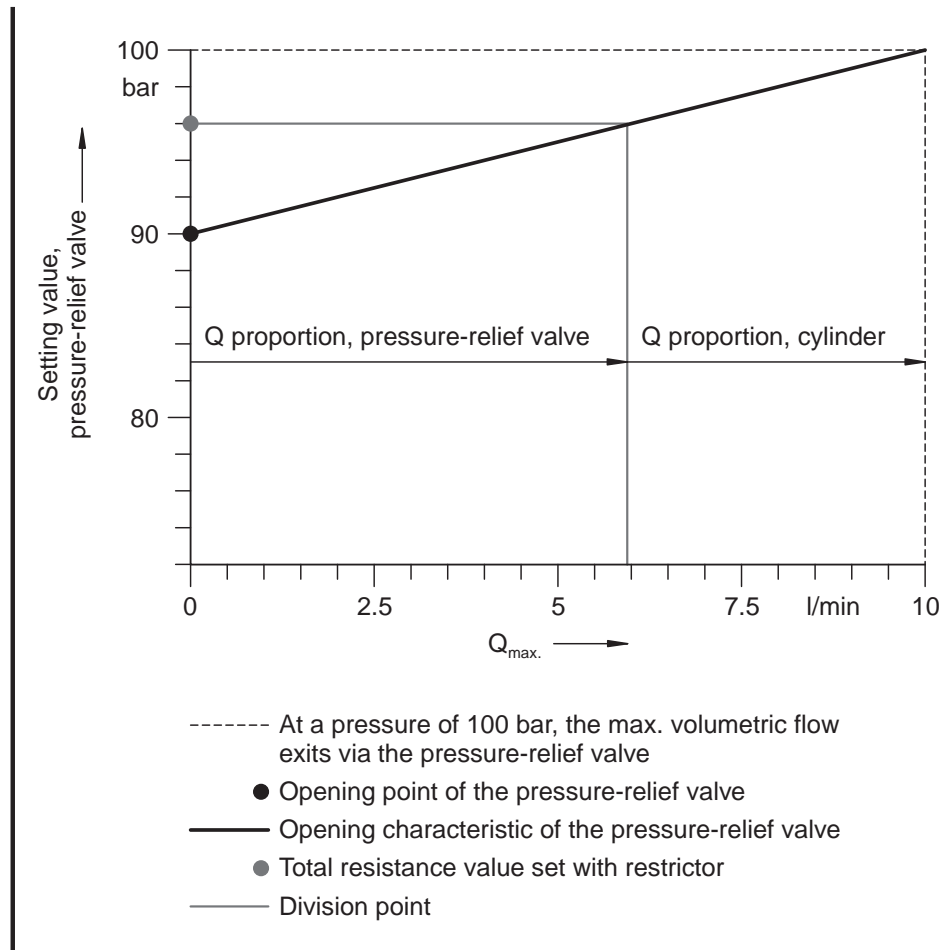

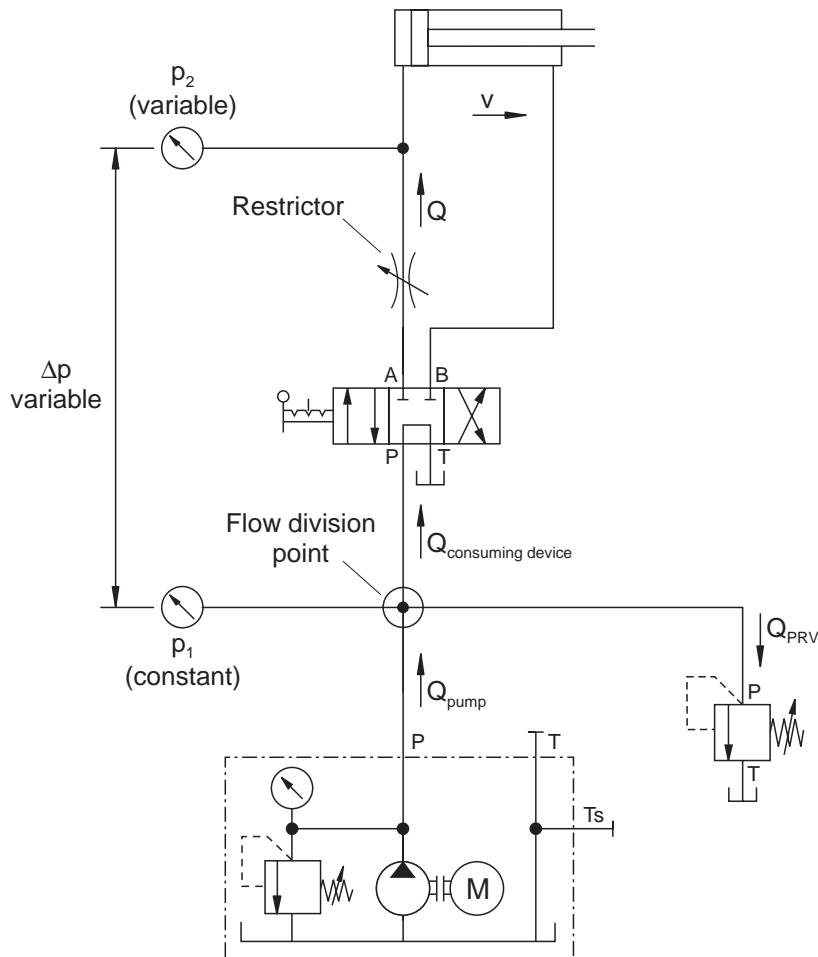

Restrictor – Flow division

The requirements for adjustable restrictors are as follows:

- build-up of a resistance;
- constant resistance in the face of changing hydraulic fluid temperatures, i. e. independent of viscosity;
- sensitive adjustment – the sensitivity of adjustment of a restrictor is dependent amongst other things, on the ratio of the orifice cross-sectional area to the control surface area;
- economical design.

Adjustable restrictors

The various designs of adjustable restrictor fulfil these requirements with varying degrees of success:

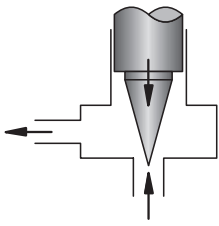
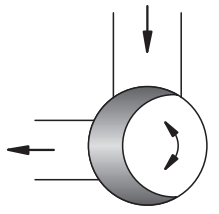
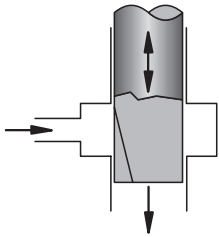
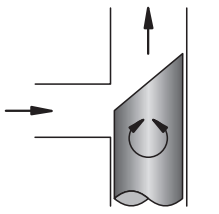
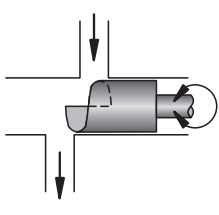
Type	Resistance	Dependence on viscosity	Ease of adjustment	Design
 <p>Needle restrictor</p>	Increase in velocity, high friction owing to long throttling path	Considerable owing to high friction	Excessive cross-sectional enlargement with a short adjustment travel, unfavourable ratio area to control surface	Economical, simple design
 <p>Circumferential restrictor</p>	As above	As above, but lower than for the needle restrictor	Steadier cross-sectional enlargement, even ratio area to control surface, total adjustment travel only 90°.	Economical, simple design, more complicated than the needle restrictor
 <p>Longitudinal restrictor</p>	As above	As above	As above, however sensitive adjustment owing to long adjustment travel	As for circumferential restrictor
 <p>Gap restrictor</p>	Main part: increase in velocity, low friction, short throttling path	Low	Unfavourable, even cross-sectional enlargement, adjustment travel of 180°	Economical
 <p>Gap restrictor with helix</p>	Increase in velocity, maximum friction	Independent	Sensitive, even cross-sectional enlargement, adjustment travel of 360°	Expensive to produce helix

Adjustable restrictors

The one-way flow control valve where the restrictor is only effective in one direction is a combination of a restrictor and a non-return valve. The restrictor controls the flow rate in a single direction dependent on flow. In the opposite direction, the full cross-sectional flow is released and the return flow is at full pump delivery. This enables the one-way flow control valve to **operate** as follows:

The hydraulic flow is throttled in the flow direction from A to B. This results in flow division as with the restrictor. Flow to the power component is reduced, the speed being reduced correspondingly.

Flow is not restricted in the opposite direction (B to A) as the sealing cone of the non-return valve is lifted from its valve seat and the full cross-sectional flow is released.

With adjustable one-way flow control valves, the throttling point can either be enlarged or reduced.

## 12.2 One-way flow control valve

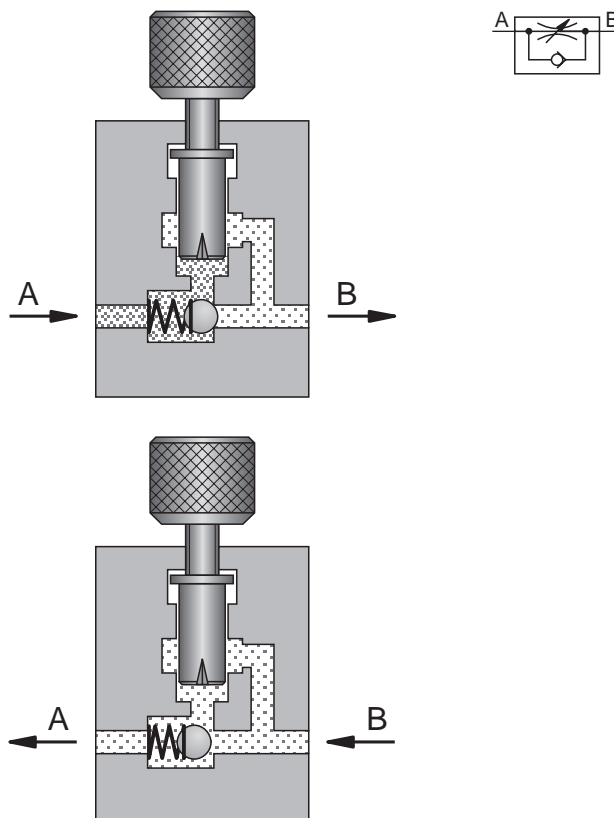

One-way flow control valve

### 12.3 Two-way flow control valves

As has already been described in the section on restrictors, there is an interrelationship between pressure drop  $\Delta p$  and volumetric flow  $Q$ :  $\Delta p \sim Q^2$ .

If, in the case of a changing load, an even flow rate to the consuming device is required, the pressure drop  $\Delta p$  via the throttle point must be kept constant. Therefore, a restrictor (2) (adjustable restrictor) and a second restrictor (1) (regulating restrictor or pressure balance) are built-in for the desired flow rate. These restrictors change their resistance according to the pressures present at the input and output of the valve. The total resistance of the two restrictors combined with the pressure relief valve causes the flow division.

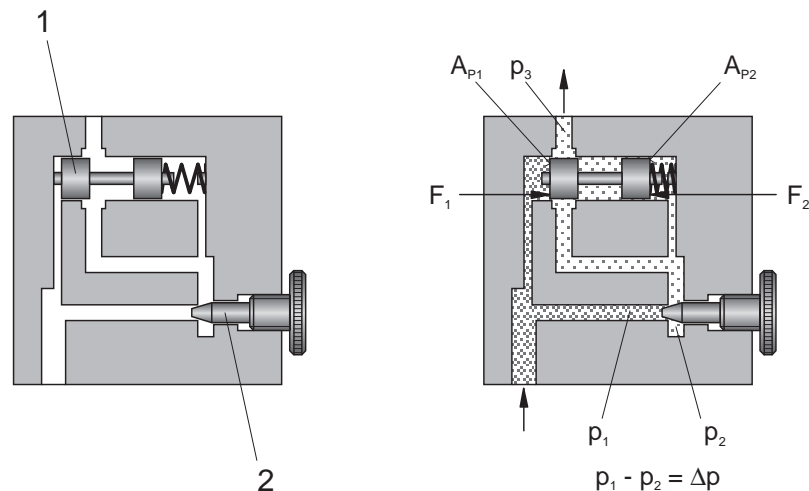

2-way flow control valve

The regulating restrictor (1) can be installed either ahead of or behind the adjustable restrictor.

The valve is open in the normal position. When flow passes through the valve, input pressure  $p_1$  is produced ahead of the adjustable restrictor. A pressure drop  $\Delta p$  is produced at the adjustable restrictor, i.e.  $p_2 < p_1$ . A spring must be installed on the side  $F_2$  so that the regulating restrictor retains its equilibrium. This spring causes the constant pressure difference across the adjustable throttle. If a load passes from the consuming device to the valve output, the regulating restrictor reduces the resistance by the amount by which the load has increased.

During idling, the spring helps to keep the regulating restrictor in equilibrium and the valve provides a certain resistance which is adjusted in line with the desired flow rate using the adjustable restrictor.

If the pressure at the **output** of the valve **increases**, the pressure  $p_3$  also increases. As a result, the pressure difference is modified via the adjustable restrictor. At the same time,  $p_2$  operates on the piston surface  $A_{P2}$ . The force which arises combines with the spring force to act on the regulating restrictor. The regulating restrictor remains open until there is once more a state of equilibrium between the forces  $F_1$  and  $F_2$  and, therefore, the pressure drop at the adjustable restrictor regains its original value. As with the restrictor, the residual flow not required at the 2-way flow control valve is discharged via the pressure relief valve to the tank.

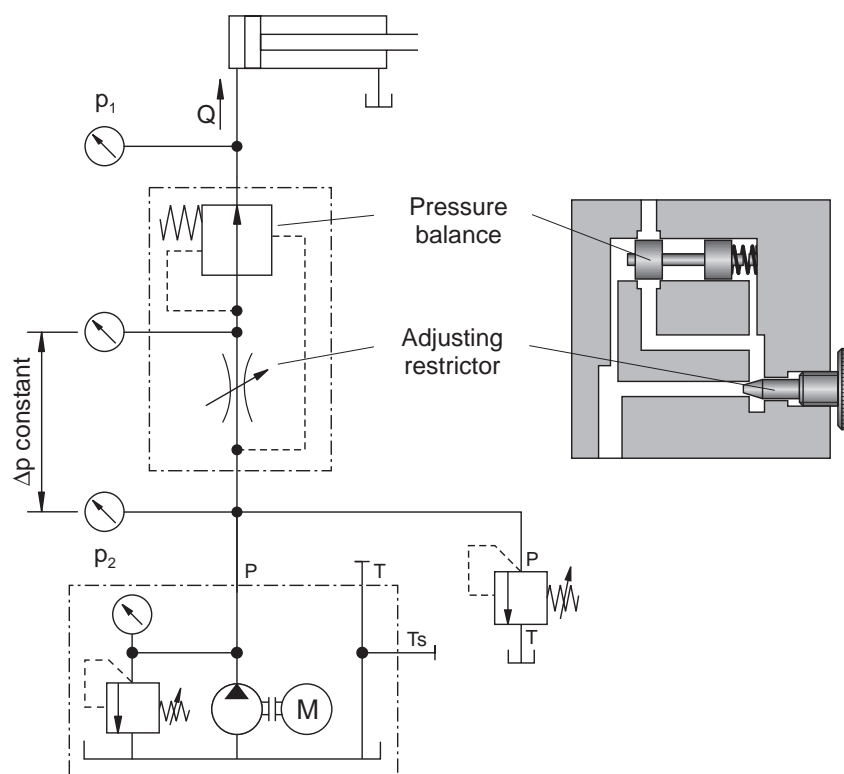

2-way flow control valve

If the pressure  $p_3$  at the **output** of the valve **falls**, the pressure difference  $\Delta p$  increases. As a result, the pressure acting on the piston surface  $A_{P2}$  is also reduced with the consequence that the force  $F_1$  becomes greater than  $F_2$ . The regulating restrictor now recloses until an equilibrium is established between  $F_1$  and  $F_2$ .

The same regulating function operates with fluctuating input pressures. With changed input conditions,  $\Delta p$  via the adjustable restrictor and, thus, also the delivery to the consuming device remain constant.

Tasks of the regulating restrictor

As previously discussed, the function of the regulating restrictor is to balance out changes in load at the input or output through modification of its flow resistance, and, by these means, to maintain a constant pressure difference via the adjustable restrictor. For this reason, there must be an equilibrium of forces at the regulating piston so that it can adjust to changing loads; i.e.  $F_1 = F_2$ .

$F_1$  is produced from the area  $A_{P1}$  and the pressure  $p_1$ .  $F_2$  results from the area  $A_{P2}$ , which is equal to  $A_{P1}$  and the pressure  $p_2$ . Since the pressure  $p_2$  is reduced by the resistance of the adjustable restrictor, a spring must be installed for the purposes of balance.

$$F_1 = F_2 \qquad A_{P1} = A_{P2}$$

$$F_1 = A_{P1} \cdot p_1$$

$$F_2 = A_{P2} \cdot p_2 + F_F$$

---

$$A_{P1} \cdot p_1 = A_{P1} \cdot p_2 + F_F$$

$$A_{P1} (p_1 - p_2) = F_F$$

$$(p_1 - p_2) = \frac{F_F}{A_{P1}}$$

This means: The constant spring force  $F_F$  divided by the piston area  $A_{P1}$  equals the pressure difference  $\Delta p$ . This difference across the adjustable restrictor is always kept constant as shown by the following examples.

**Note:**

In practice, adjustable restrictors are generally designed in the form of adjustable orifices so that the flow control valve remains to a large degree unaffected by viscosity.



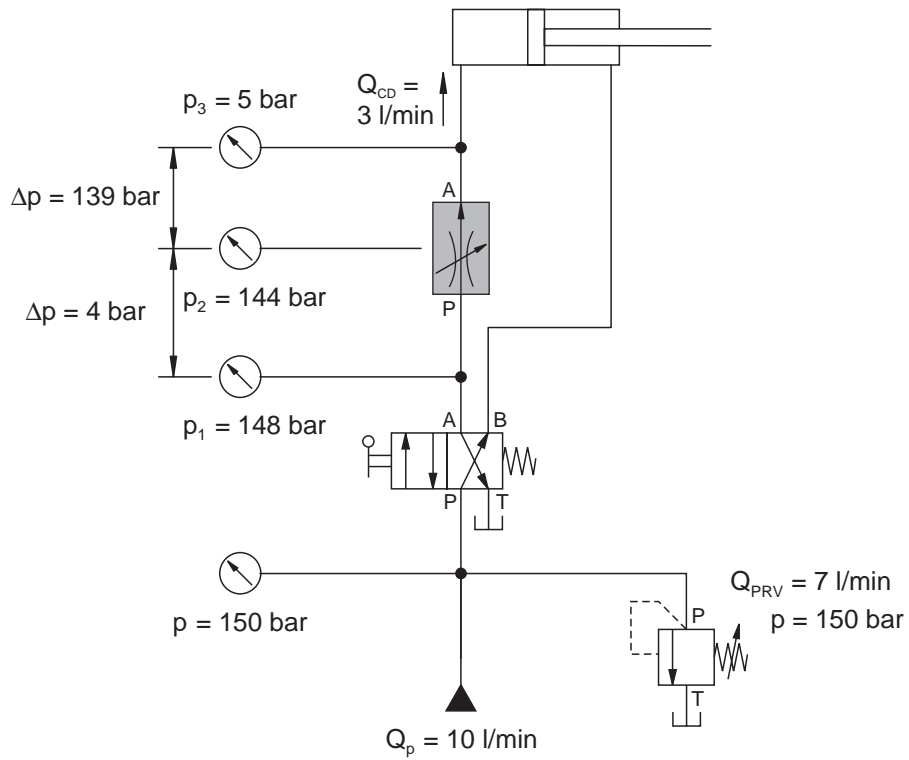

2-way flow control valve, loading of the consuming device (idling)

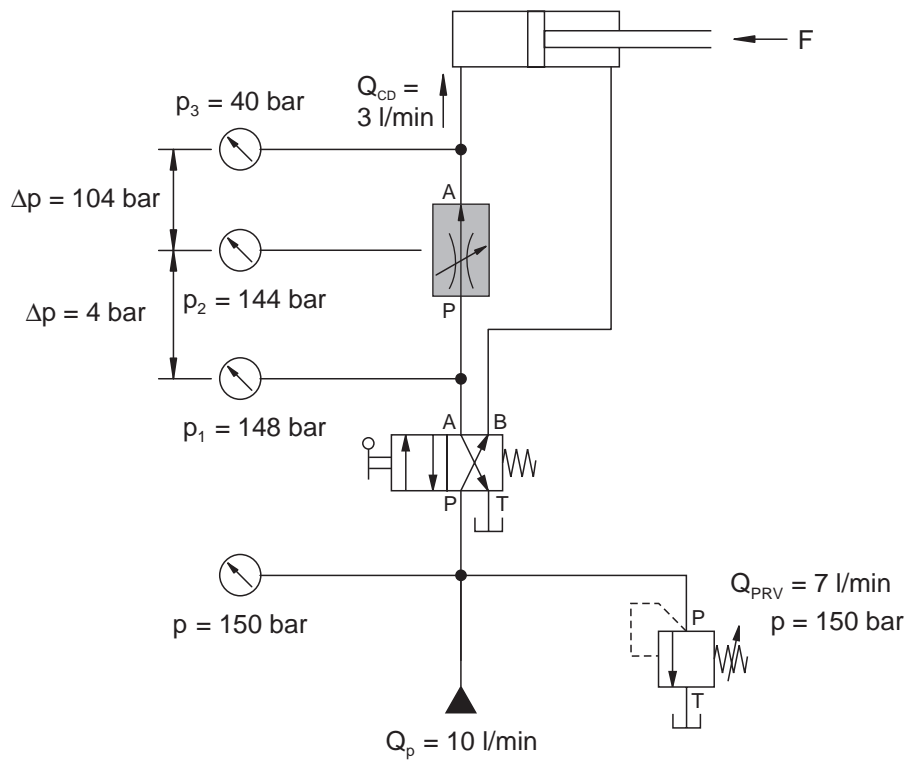

2-way flow control valve, loading of the consuming device (under load)

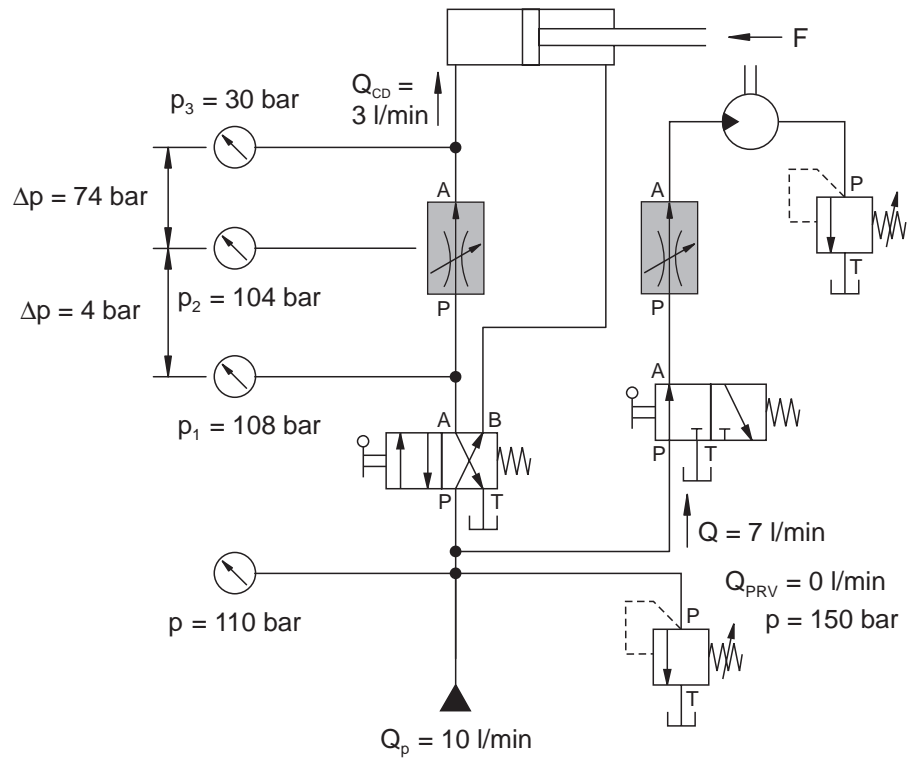

*In connection with other  
consuming devices*

There is both a detailed and a simplified symbol for the 2-way flow control valve.

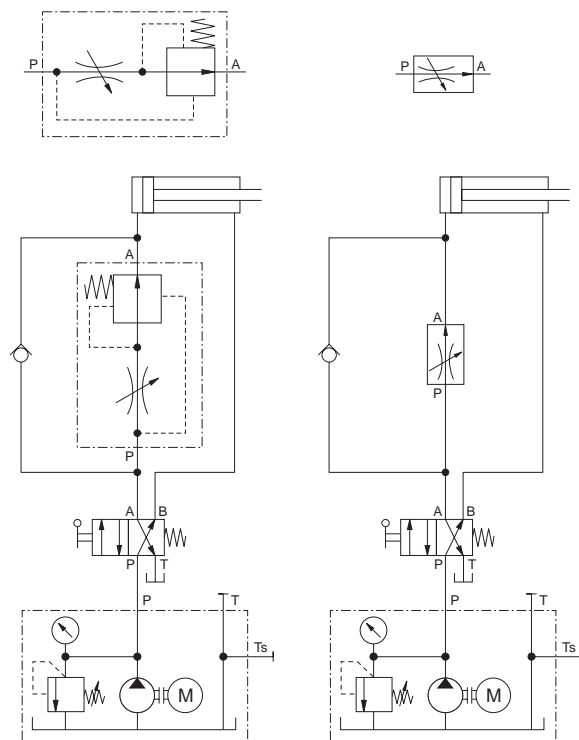

2-way flow control valve

2-way flow control valves may be used either in the inlet and/or outlet and for by-pass flow control.

Disadvantage of by-pass flow control: The uneven pump delivery caused by fluctuations in speed has an effect on the flow quantity to be regulated.

2-way flow control valves provide a constant flow rate in the face of changing loads meaning that they are suitable for the following application examples:

- Workpiece slides which operate at a constant feed speed with varying working loads;
- Lifting gear where the lowering speeds need to be carefully restricted.

**Note**

The flow control valve is opened when the system is at a standstill. Once the system has been switched on, there is a higher flow rate until the pressure balance has been set to the desired position; this procedure is referred to as the **initial jump**. There are several ways to reduce the initial jump.

- A by-pass valve opens before the main valve opens.
- Or the measuring restrictor is closed by a spring in unpressurised status.

# **Chapter 13**

## **Hydraulic cylinder**

The hydraulic cylinder converts hydraulic energy into mechanical energy. It generates linear movements. For this reason, it is also referred to as a “linear motor”.

There are two basic types of hydraulic cylinder

- single-acting and
- double-acting cylinders.

Sectional views of these two basic types are shown in the diagrams below.

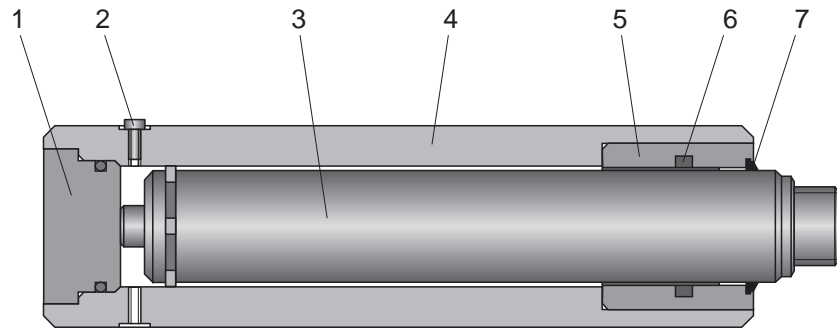

- |                   |                      |
|-------------------|----------------------|
| 1 Mounting screw  | 5 Piston rod bearing |
| 2 Vent screw      | 6 Piston rod seal    |
| 3 Piston rod      | 7 Wiper              |
| 4 Cylinder barrel |                      |

*Single acting cylinder*

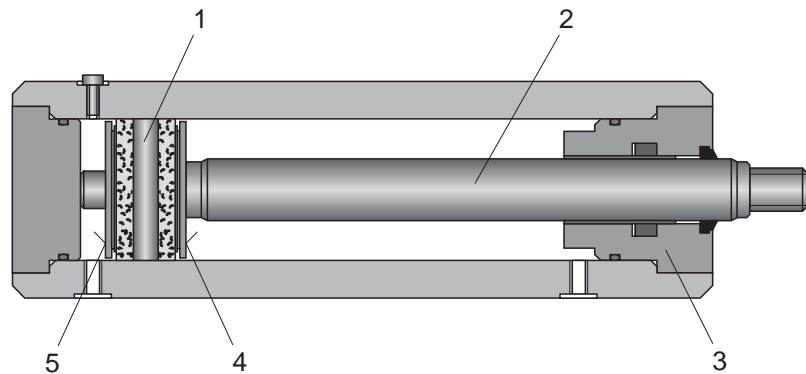

- |                          |
|--------------------------|
| 1 Piston                 |
| 2 Piston rod             |
| 3 Piston rod bearing     |
| 4 Annular piston surface |
| 5 Piston surface         |

*Double acting cylinder*

In single-acting cylinders, only the piston side is supplied with hydraulic fluid. Consequently, the cylinder is only able to carry out work in one direction. These cylinders operate according to the following principle: The hydraulic fluid flows into the piston area. Owing to the counter force (weight/load), pressure builds up at the piston. Once this counter force has been overcome, the piston travels into the forward end position.

During the return stroke, the piston area is connected to the reservoir via the line and the directional control valve whilst the pressure line is closed off by the directional control valve. The return stroke is effected either by intrinsic load, by a spring or by the weight load. In the process, these forces (load forces) overcome the frictional forces in the cylinder and in the lines and valves and displace the hydraulic fluid into the return line.

**13.1 Single-acting cylinder**

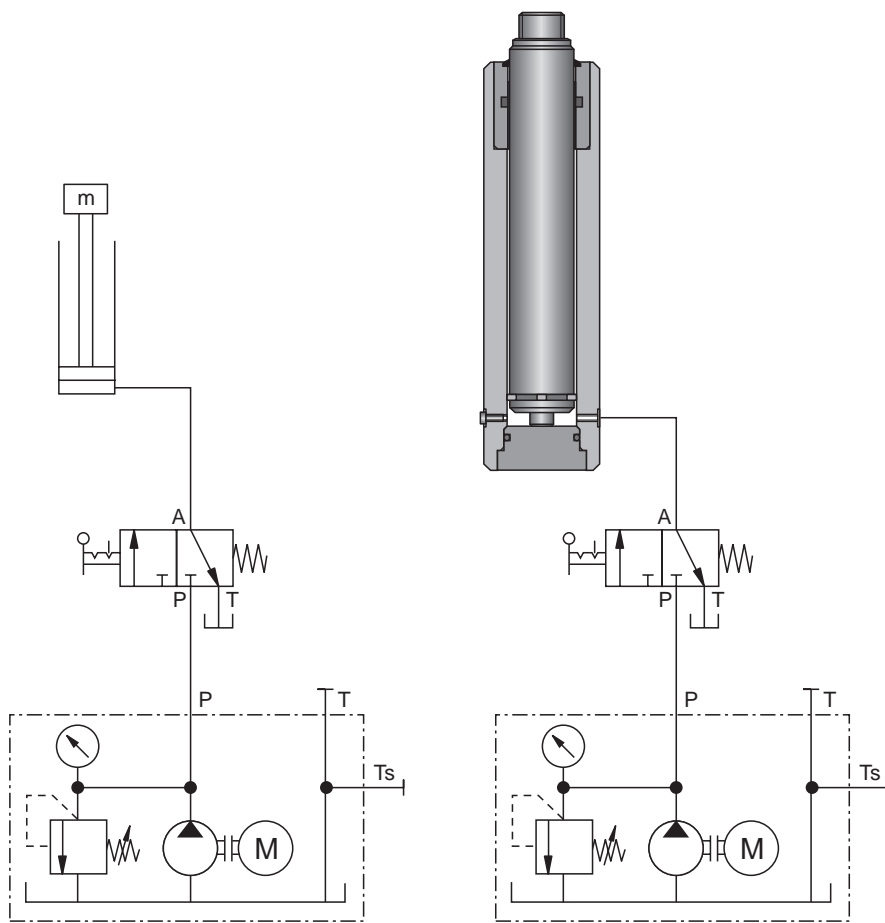

Single acting cylinder – hydraulic ram

Possible applications Single-acting cylinders are used wherever hydraulic power is required for only one direction of motion.

Examples For lifting, clamping and lowering workpieces, in hydraulic lifts, scissor lifting tables and lifting platforms.

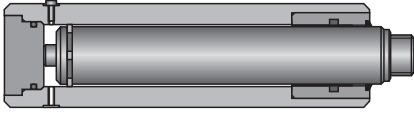
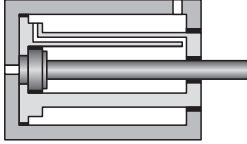
	Hydraulic ram	piston and rod form one unit	
<i>Single acting cylinder</i>	Telescopic cylinder	longer strokes	

Single-acting cylinders can be mounted as follows:

- vertical mounting: when the return movement of the piston is brought about by external forces (special instance: scissor lifting table);
- horizontal mounting: for single-acting cylinders with spring-return.

In large hydraulic presses, the return stroke is brought about by pull-back cylinders.

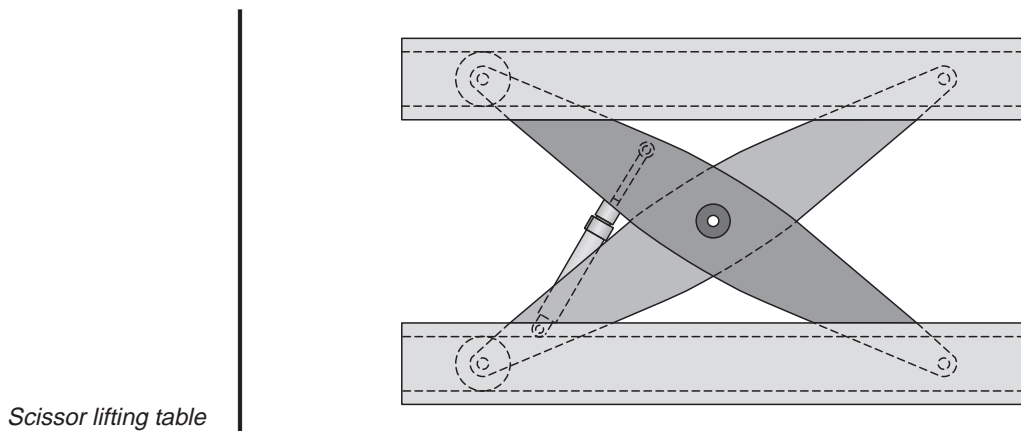



In the case of double-acting cylinders, both piston surfaces can be pressurized. Therefore, it is possible to perform a working movement in both directions. These cylinders operate according to the following principle:

The hydraulic fluid flows into the piston area and pressurises the piston surface. Internal and external resistances cause the pressure to rise. As laid down in the law  $F = p \cdot A$ , a force  $F$  is produced from the pressure  $p$  and the piston surface area  $A$ . Consequently, the resistances can be overcome and the piston rod extends. This is possible owing to the conversion of hydraulic energy into mechanical energy which is made available to a consuming device.

### 13.2 Double-acting cylinders

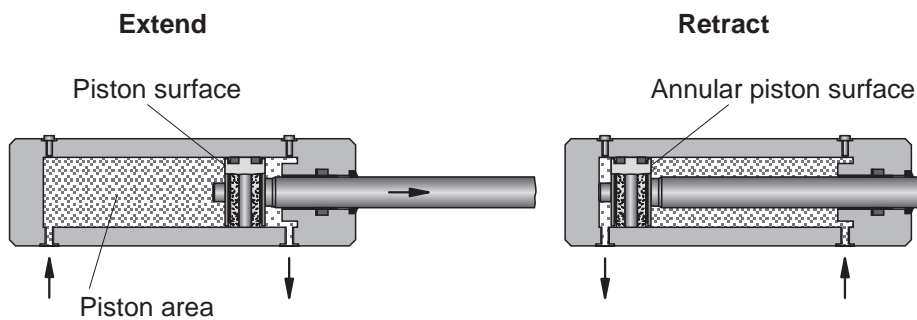

*Double acting cylinder*

It should be borne in mind that when the piston extends the oil on the piston rod side must be displaced via the lines into the reservoir. During the return stroke, the hydraulic fluid flows into the (annular) piston rod area. The piston retracts and the oil quantity is displaced from the piston area by the piston.

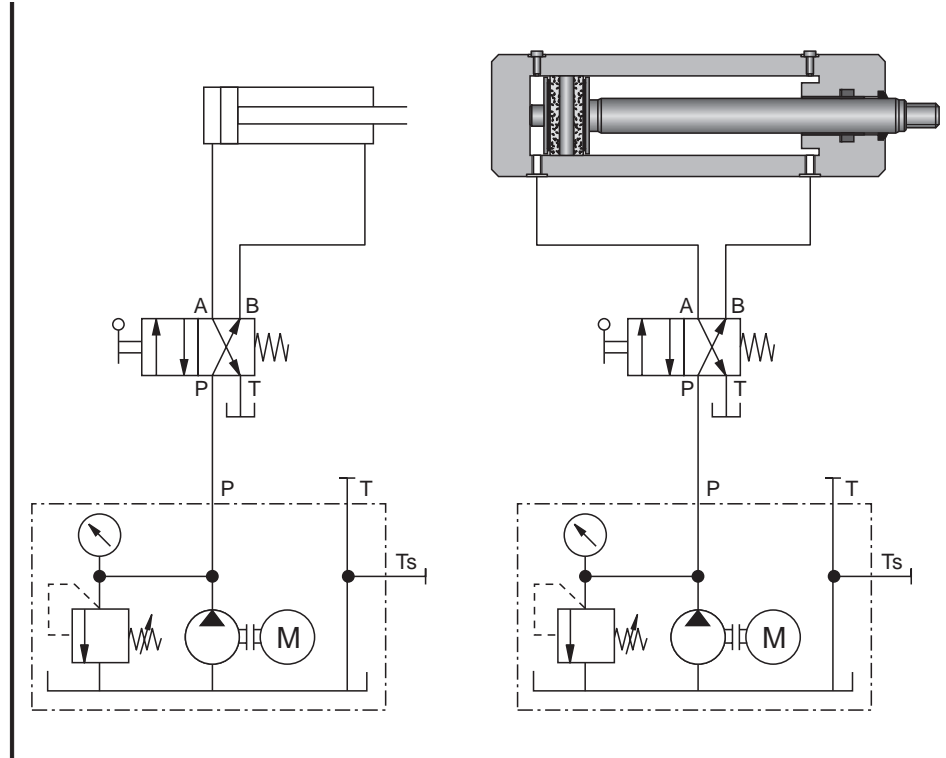

Double-acting cylinder

In double acting cylinders with a single-sided piston rod, different forces ( $F = p \cdot A$ ) and speeds are produced for the same flow rate on extension and retraction owing to the differing surfaces (piston surface and annular piston surface).

The return speed is higher since, although the flow rate is identical, the effective surface is smaller than for the advance stroke. The following equation of continuity applies:

$$v = \frac{Q}{A}$$

The following designs of double-acting cylinders exist fulfilling varying requirements:

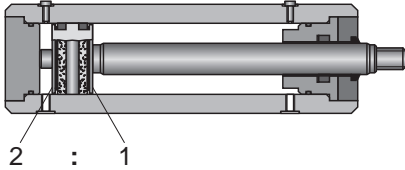
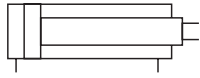
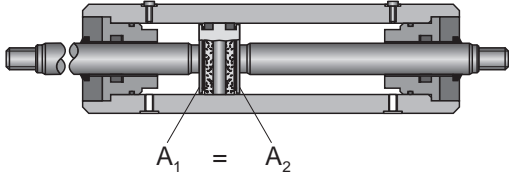
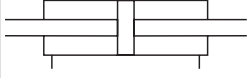
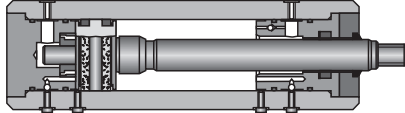
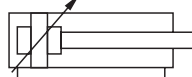
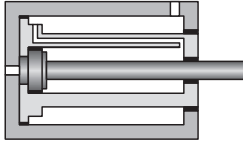
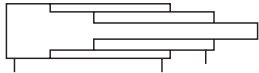
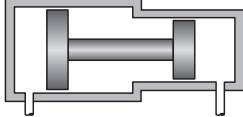
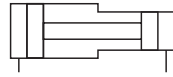
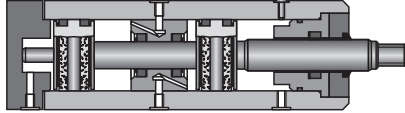
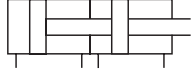
<b>Differential cylinder</b>	Area ratio 2:1 (piston surface: annular piston surface) piston return stroke twice as fast as advance stroke		
<b>Synchronous cylinder</b>	Pressurised area of equal size. Advance and return speeds identical		
<b>Cylinder with end-position cushioning</b>	To moderate the speed in the case of large masses and prevent a hard impact.		
<b>Telescopic cylinder</b>	Longer strokes		
<b>Pressure intensifier</b>	Increases pressure		
<b>Tandem cylinder</b>	When large forces are required and only small cylinder dimensions are possible.		

Cylinder types

The movements generated by hydraulic cylinders are used for:

■ **Machine tools**

- Feed movements for tools and workpieces;
- Clamping devices;
- Cutting movements on planing machines;
- shock-testing machines and broaching machines;
- Movements on presses;
- Movements on printing and injection moulding machines, etc.

■ **Handling devices and hoists**

- Tilting, lifting and swivel movements on tippers, fork-lift trucks, etc.

■ **Mobile equipment**

- Excavators,
- Power loaders,
- Tractors,
- Fork-lift trucks,
- Tipper vehicles.

■ **Aircraft**

- Lifting, tilting and turning movements on landing gear, wing flaps, etc.

■ **Ships**

- Rudder movements, adjustment of propellers

Cylinders with end position cushioning are used to brake high stroke speeds. They prevent a hard impact at the end of the stroke.

### 13.3 End position cushioning

Cushioning is not required for speeds of  $v < 6$  m/min. At speeds of  $v \geq 6-20$  m/min, cushioning is achieved by means of restrictors or brake valves. At speeds of  $v > 20$  m/min, special cushioning or braking procedures are required.

When the piston returns to the retracted end position, the normal discharge of the hydraulic fluid from the piston area is interrupted by the cushioning piston and flow is reduced from a certain point until it is finally closed. The hydraulic fluid in the piston area must then flow away via a restrictor (see diagram).

In this way, the piston speed is reduced and there is no danger of malfunctions resulting from high speeds. When the cylinder extends, the oil flows unhindered via the non-return valve, the throttle point being by-passed. To achieve end position cushioning, the pressure relief valve (flow division) must be used.

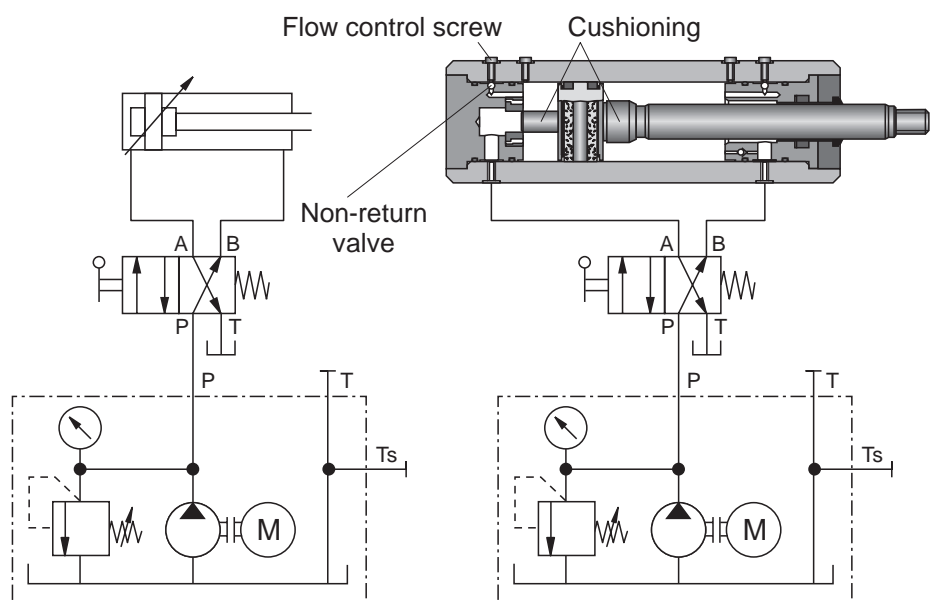

*Double-acting cylinder with end position cushioning*

In addition to this simple type of end position cushioning, there is also double cushioning for **forward and retracted end positions**. With this type of cushioning, a hard impact is avoided both on advancing and on retracting.

**13.4 Seals** The function of seals is to prevent leakage losses in hydraulic components. Since pressure losses also occur as a result of leakage losses, seals are of considerable importance for the efficiency of a hydraulic system.

In general, static seals are inserted between stationary parts and dynamic seals between movable parts.

- Static seals:
  - O-rings for the cylinder housing;
  - flat seals for the oil reservoir cover;
  
- Dynamic seals:
  - Piston and piston rod seals;
  - rotary shaft seals on turning devices.

The recommended maximum piston speed is approx. 0.2 m/s. and is dependent on the operating conditions as well as the sealing material and type of seal. Where extremely low speeds and/or a minimal break-away force are required, special sealing materials, systems and modified cylinder surfaces must be used.

The seals pictured opposite are used on cylinders according to requirements (pressure, temperature, velocity, diameter, oil, water):

**Seals on the piston**

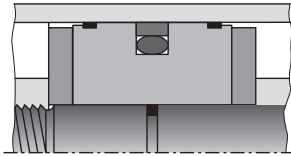

Slip-ring seal:  
 For low piston speeds at  
 low pressure  
 Three parts: pressure ring  
 sealing ring  
 support ring

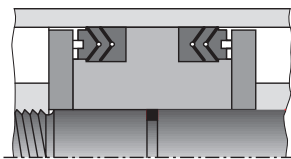

Packing seal:  
 For heavy-duty conditions  
 Three parts: pressure ring  
 sealing ring  
 support ring

**Seals on the piston rod**

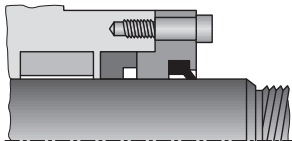

Seals on the piston  
 rod, slip-ring seal with  
 scraper ring

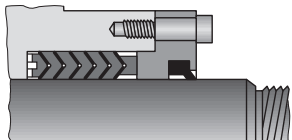

Packing seal  
 with scraper ring,  
 re-adjustable

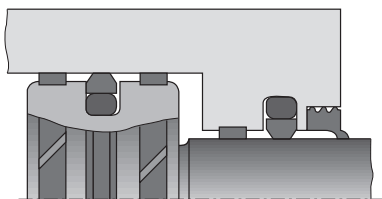

Sealing component of PTFE  
 for high speed and  
 high pressure,  
 contact force by means of  
 O-ring

*Cylinder seals*

**13.5 Types of mounting** Cylinders are mounted in various ways according to usage. Some types of mounting are shown in the diagram.

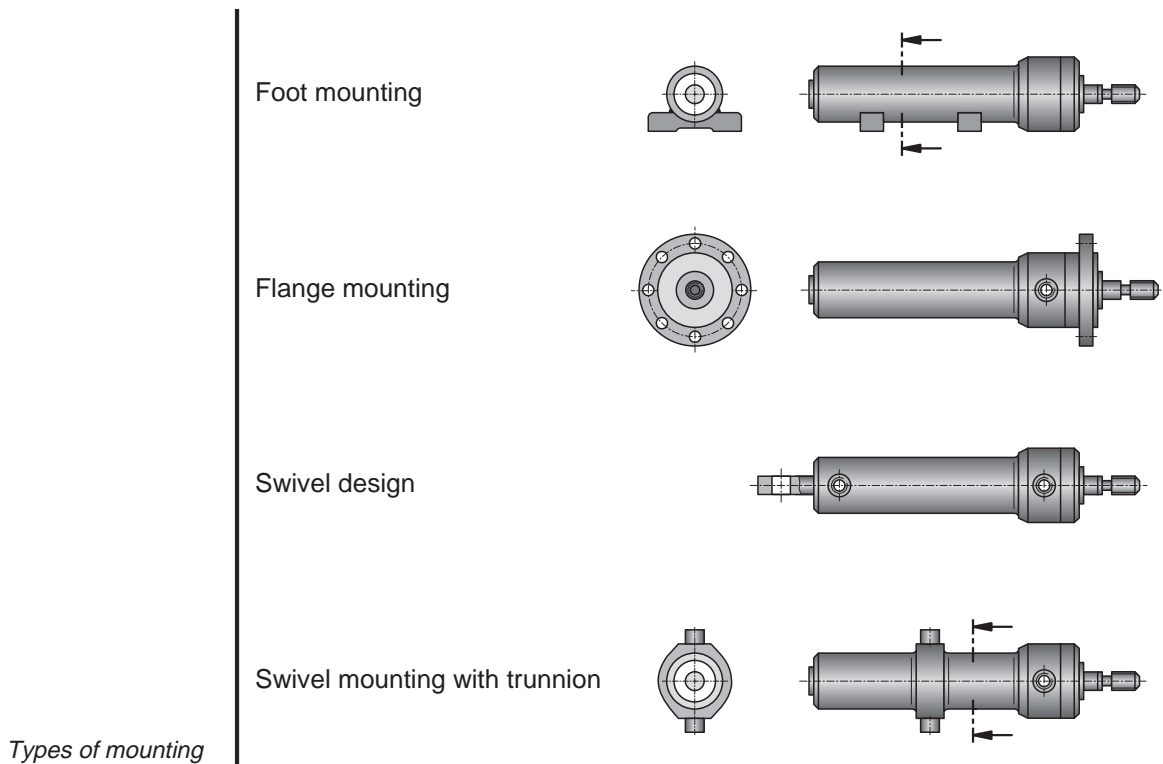

**13.6 Venting** A hydraulic cylinder must be vented to achieve jolt-free travel of a cylinder piston, i.e. the air carried along in the lines must be removed. As trapped air always gathers at the highest point of a system of lines, a vent screw or automatic venting valve must be positioned at this point.

Hydraulic cylinders are supplied with vent screws at both end positions. These ports can also be used for connecting pressure gauges.



The cylinder is selected to suit the load  $F$ . The required pressure  $p$  is selected in accordance with the application.

### 13.7 Characteristics

$$F = p \cdot A$$

This can be used for calculating the piston diameter. The hydraulic, mechanical efficiency  $\eta_{hm}$  must be considered here. This efficiency is dependent on the roughness of the cylinder barrel, the piston rod and the type of sealing system. The efficiency improves with increases in pressure. It lies between 0.85 and 0.95. Thus, the piston diameter is derived from:

$$F = p \cdot A \cdot \eta_{hm}$$

$$A = \frac{d^2 \cdot \pi}{4}$$

$$A = \frac{F}{p \cdot \eta_{hm} \cdot \pi}$$

$$d = \sqrt{\frac{4F}{p \cdot \eta_{hm} \cdot \pi}}$$

The volumetric efficiency  $\eta_v$  takes into consideration the leakage losses at the piston seal. Where the seal is intact,  $\eta_v = 1.0$  and is not, therefore, taken into consideration.

Cylinder diameter, piston rod diameter and nominal pressures are standardised in DIN 24334 and DIN ISO 3320/3322. In addition, a preferred ratio  $\phi$  = piston area  $A_P$  to annular piston area  $A_{PR}$  is laid down.

	12	16	20		25		32		40	50	63	80
<i>Internal diameter of the cylinder</i>	100	125	160	200	220	250	280	320	360	400		

	8	10		12	14	16	18	20	22	25	28	32	36	40	45	50	63	70	80	90
<i>Piston rod diameter</i>		100	110	112	140	160	180	200	220	250	280	320	360							

<i>Nominal pressures</i>	<u>25</u>	40	<u>63</u>	100	<u>160</u>	200	<u>250</u>	315	<u>400</u>	500	<u>630</u>
--------------------------	-----------	----	-----------	-----	------------	-----	------------	-----	------------	-----	------------

The values which are underlined are recommended values. The recommended range of piston strokes is laid down in DIN ISO 4393 and for piston rod threads in DIN ISO 4395.

In the table below, the area  $A_P$  appropriate to the cylinder diameter  $d_P$  and the annular piston area  $A_{PR}$  (not the piston rod area  $A_{ST}$ ) for the piston rod diameter  $d_{ST}$  are assigned to the area ratio  $\varphi$ .

$$\varphi = \frac{A_P}{A_{PR}} \quad A_{PR} = A_P - A_{ST}$$

Nominal value $\varphi$	$d_P$	25	32	40	50	60	63	80	100	125
	$A_{PR} \text{ cm}^2$	4.91	8.04	12.6	19.6	28.3	31.2	50.3	78.5	123
1.25	$d_{ST}$	12	14	18	22	25	28	36	45	56
	$A_{PR} \text{ cm}^2$	3.78	6.50	10.0	15.8	23.4	25.0	40.1	62.2	98.1
	$\varphi$ Actual value	1.30	1.24	1.25	1.24	1.21	1.25	1.25	1.26	1.25
1.4	$d_{ST}$	14	18	22	28	32	36	45	56	70
	$A_{PR} \text{ cm}^2$	3.37	5.50	8.77	13.5	20.2	21	34.4	54	84.2
	$\varphi$ Actual value	1.46	1.46	1.44	1.45	1.39	1.49	1.46	1.45	1.46
1.6	$d_{ST}$	16	20	25	32	36	40	50	63	80
	$A_{PR} \text{ cm}^2$	2.90	4.90	7.66	11.6	18.2	18.6	30.6	47.7	72.4
	$\varphi$ Actual value	1.69	1.64	1.64	1.69	1.55	1.68	1.64	1.66	1.69
2	$d_{ST}$	18	22	28	36	40	45	56	70	90
	$A_{PR} \text{ cm}^2$	2.36	4.24	6.41	9.46	15.7	15.3	25.6	40.0	59.1
	$\varphi$ Actual value	2.08	1.90	1.96	2.08	1.8	2.04	1.96	1.96	2.08
2.5	$d_{ST}$	20	25	32	40	45	50	63	80	100
	$A_{PR} \text{ cm}^2$	1.77	3.13	4.52	7.07	12.3	11.5	19.1	28.4	44.2
	$\varphi$ Actual value	2.78	2.57	2.78	2.78	2.3	2.70	2.64	2.78	2.78
5	$d_{ST}$	–	–	–	45	55	56	70	90	110
	$A_{PR} \text{ cm}^2$	–	–	–	3.73	4.54	6.54	11.8	14.9	27.7
	$\varphi$ Actual value	–	–	–	5.26	6.2	4.77	4.27	5.26	4.43

Table for the area ratio  $\varphi$

This table gives the area ratios up to a piston diameter of 125 mm. The complete table is included in DIN 3320.

**13.8 Buckling resistance**

Buckling resistance as defined by Euler must be taken into consideration when deciding on piston rod diameter and stroke length. Manufacturer's tables are available for this. When installing the cylinder, it is necessary to insure that no distortions are possible. In addition, the direction of force must be effective in the axial direction of the cylinder.

The permissible buckling force  $F_{perm}$  for a pressurised load is calculated as follows:

$$F_{perm.} = \frac{\pi^2 \cdot E \cdot I}{l_K^2 \cdot v}$$

$E$  = Elasticity module [ $\frac{daN}{cm^2}$ ] (for steel =  $2.1 \cdot 10^6$ )

$I$  = Area moment [ $cm^4$ ] (for  $\varnothing = \frac{d^4 \cdot \pi}{64} = 0.0491 \cdot d^4$ )

$l_K$  = Free buckling length [cm]

$v$  = Safety factor 2.5 - 3.5

The free buckling length  $l_P$  is dependent on the load in question:

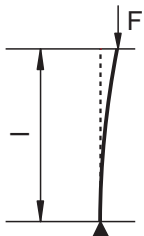
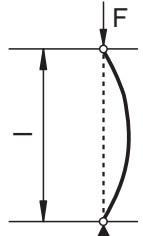
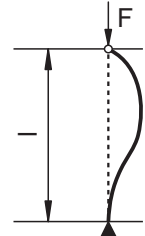
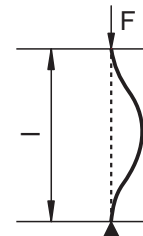
1st method	2nd method (Basic case)	3rd method	4th method
One end free, one end firmly clamped	Two ends with flexible guide	One end with flexible guide, one end firmly clamped	Two ends firmly clamped
			
$l_K = 2l$	$l_K = l$	$l_K = l \cdot \sqrt{\frac{1}{2}}$ (0.707)	$l_K = \frac{1}{2}l$

Alternative clamping methods as defined by Euler

Cylinders are designed for tensile and pressure forces only. Shearing forces must be absorbed by guides.

**Note:**

The type of mounting and installation determines the Euler method on which it should be based.

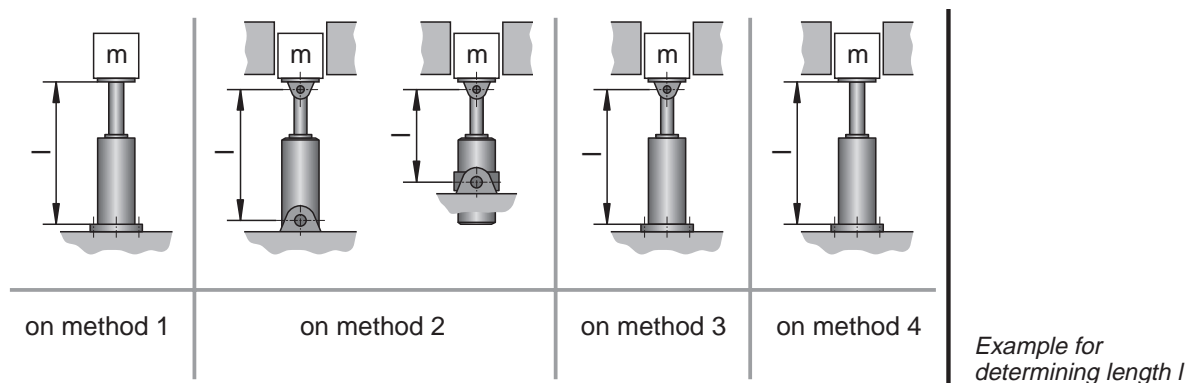

**The following apply in principle:**

The length  $l$  is calculated from the attachment area of the flange or other fixed bearing method (pivot pin, etc.). If the flange or pivot pin is at the cylinder head, for example, the length  $l$  is calculated from this point.

Mounting methods three and four should be avoided wherever possible. Distortion may occur where the load guide is imprecise in these areas.

### 13.9 Selecting a cylinder

Example: lifting device

A differential cylinder with the area ratio  $\phi$  of 2:1 is to lift 40 kN 500 mm in 5 secs. The maximum system pressure for the pump is to be 160 bar.

Calculate the piston diameter  $d_P$  and find the piston rod diameter  $d_{ST}$  in the area ratio table. On the basis of the piston rod diameter  $d_{ST}$ , find the maximum possible stroke length from the buckling resistance diagram (p.245). In addition, calculate the advance and return speeds for the piston and the pump delivery.

The mechanical, hydraulic efficiency of the cylinder amounts to  $\eta_{mh} = 0.95$ . Pipe loss amounts to 5 bar, pressure drop in the directional control valve 3 bar and back pressure from the return movement 6 bar.

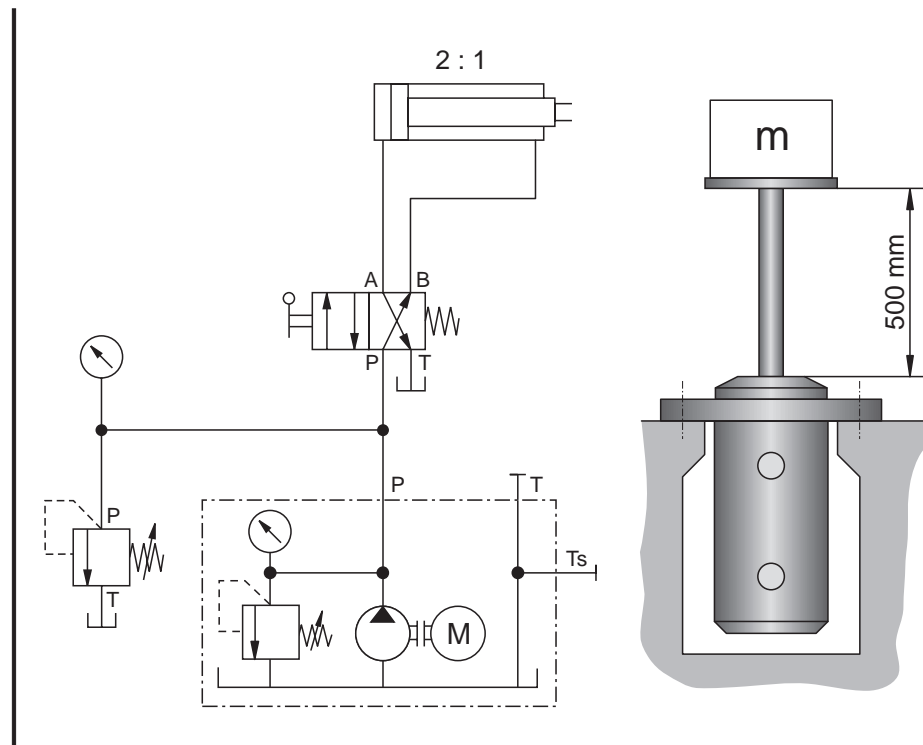

Lifting device

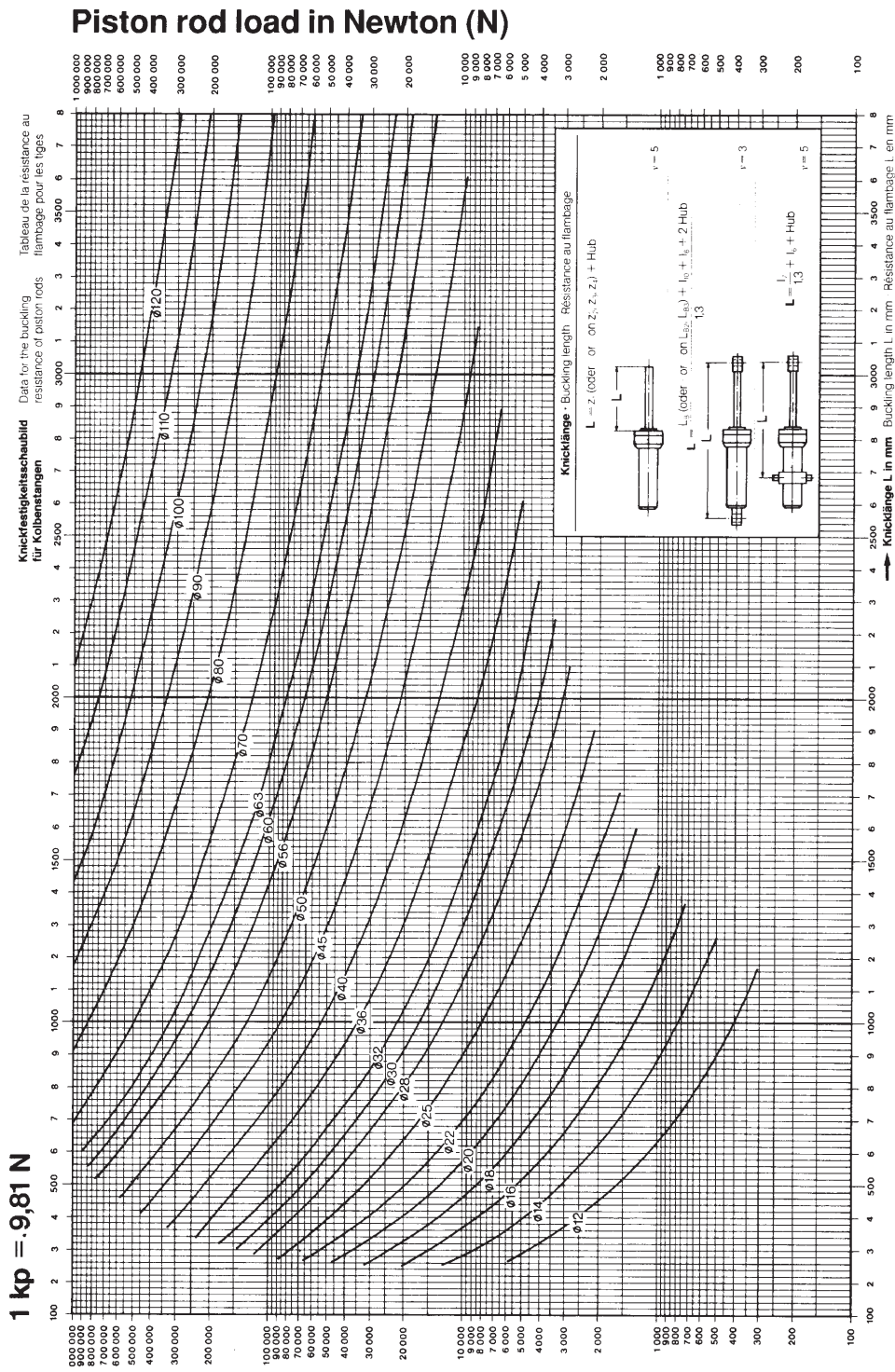

Buckling resistance diagram

The safety factor  $\nu$  is already included in the buckling resistance diagram.

Calculate the required piston diameter  $d_P$ .

Available system pressure	160 bar
minus line loss	5 bar
pressure loss in the directional control valve	3 bar
pressure from the return movement when	

$$\varphi = 2:1 = \frac{6 \text{ bar}}{2} \quad \underline{\quad 3 \text{ bar} \quad}$$

Thus, the following pressure force remains at the cylinder  $160 - 11 = 149 \text{ bar}$

$$F = p \cdot A_P \cdot \eta_{hm}$$

$$A_P = \frac{F}{p \cdot \eta_{hm}}$$

$$A_P = \frac{40000 \text{ N} \cdot \text{cm}^2}{1490 \cdot 0.95 \text{ N}} \quad 149 \text{ bar} = 1490 \text{ N/cm}^2$$

$$\underline{\underline{A_P = 28.3 \text{ cm}^2}}$$

$$A_P = \frac{d_P^2 \cdot \pi}{4} \quad d_P = \sqrt{\frac{4 \cdot A_P}{\pi}}$$

$$d_P = \sqrt{\frac{4 \cdot 28.3 \text{ cm}^2}{\pi}} = \sqrt{36 \text{ cm}^2}$$

$$\underline{\underline{d_P = 6.0 \text{ cm} = 60 \text{ mm}}}$$

Chosen piston diameter  **$d_P = 63 \text{ mm}$** .

The piston rod diameter  $d_{ST} = 45 \text{ mm}$  is read from the table for the area ratio  $\varphi = 2:1$ . A maximum stroke length of **1440 mm** is read from the buckling resistance diagram for 40 kN and a piston rod diameter  **$d_{ST} = 45 \text{ mm}$** . If an area ratio of 2:1 is not required for the job, a smaller  $d_{ST}$  can be selected.



Calculating the advance stroke speed  $v$ :

$$t = 5 \text{ sec} \quad \text{Stroke} = 500 \text{ mm}$$

$$v = \frac{s}{t}$$

$$v = \frac{0.5 \text{ m}}{5 \text{ s}}$$

$$\underline{v = 0.1 \text{ m/s} = 6 \text{ m/min}}$$

Required pump delivery  $Q_p$ :

$$Q_p = A_P \cdot v$$

$$A_P = 31.2 \text{ cm}^2 = 0.312 \text{ dm}^2$$

$$v = 6 \text{ m/min} = 60 \text{ dm/min}$$

$$Q_p = \frac{0.312 \text{ dm}^2 \cdot 60 \text{ dm}}{\text{min}}$$

$$Q_p = 18.7 \text{ dm}^3/\text{min}$$

$$\underline{Q_p = 18.7 \text{ l/min}}$$

Calculating the return speed  $v_R$ :

$$Q = A_{PR} \cdot v$$

$$v = \frac{Q}{A_{PR}}$$

$A_{PR}$  is read from the table for the area ratio  $\phi = 2:1$  where  $d_{ST} = 45$  mm:

$$A_{PR} = 15.3 \text{ cm}^2 = 0.153 \text{ dm}^2$$

$$v = \frac{18.7 \text{ dm}^3}{0.153 \text{ dm}^2 \cdot \text{min}}$$

$$v = 122 \text{ dm/min}$$

$$\underline{\underline{v = 12.2 \text{ m/min}}}$$

When selecting a cylinder, it should be borne in mind that end position cushioning is necessary for a piston speed of 6m/min upwards.

Conditional on the area ratio  $\phi = 2:1$ , the return speed of the piston is twice that of the advance stroke. This also means that the outlet flow of the cylinder is twice that of the advance stroke. For this reason, you are advised to calculate the speed of the return flow before a system is sized and, where necessary, to select a larger cross-section for the return line. The control valve should also be suitable for the increased return flow, if not, then an additional valve must be installed for the exhaust.

# **Chapter 14**

## **Hydraulic motors**

Hydraulic motors are components in the working section. They are drive components (actuators). They convert hydraulic energy into mechanical energy and generate rotary movements (rotary actuator). If the rotary movement only covers a certain angular range, the actuator is referred to as a swivel drive.

Hydraulic motors have the same characteristic values as pumps. However, in the case of hydraulic values we speak of capacity rather than displacement volume. Capacity is specified by the manufacturer in  $\text{cm}^3$  per revolution along with the speed range at which the motor is able to function economically. The following equation can be used to find the capacity of a hydraulic motor:

$$p = \frac{M}{V}$$

$$Q = n \cdot v$$

$p$  = pressure (Pa)

$M$  = torque (Nm)

$V$  = geometric displacement capacity ( $\text{cm}^3$ )

$Q$  = flow rate (L/min)

$n$  = speed (r.p.m.)

The flow rate required by the motor is calculated from the capacity and the desired speed.

**Example** A motor with a capacity of  $V = 10 \text{ cm}^3$  is to operate at a speed of  $n = 600$  revolutions per minute. What flow rate ( $Q$ ) is required by the motor?

$$Q = \frac{10 \text{ cm}^3 \cdot 600}{\text{min}} = 6000 \text{ cm}^3/\text{min} = 6 \text{ dm}^3/\text{min} = 6 \text{ l/min}$$

Therefore, the pump must supply 6 l/min for the motor to turn at 600 revolutions per minute.

The mechanical power rating of a hydraulic motor is calculated as follows:

$\omega$  = angle velocity in rad/s

$$\omega = 2 \cdot \pi \cdot n$$

A hydraulic motor with a capacity of  $V = 12.9 \text{ cm}^3$  is driven with a pump delivery of  $Q = 15 \text{ l/min}$ . At the resultant speed, the turning torque  $M = 1 \text{ Nm}$ . What is this speed ( $n$ ) and what is the power rating ( $P$ )?

Example

Calculate the torque which arises when the motor brakes suddenly causing a pressure of  $140 \text{ bar}$  ( $140 \cdot 10^5 \text{ Pa}$ ) to be generated.

#### Technical Data

$$Q = 15 \text{ dm}^3/\text{min}$$

$$M = 1 \text{ Nm}$$

$$V = 12.9 \text{ cm}^3$$

Calculation of the r.p.m.  $n$ :

$$Q = n \cdot V, \quad n = \frac{Q}{V}$$

$$n = \frac{15 \text{ dm}^3}{12.9 \text{ cm}^3 \text{ min}} = \frac{15 \cdot 10^{-3} \text{ m}^3}{12.9 \cdot 10^{-6} \text{ m}^3 \text{ min}}$$

$$n = \frac{15 \cdot 10^{-3} \text{ m}^3}{12.9 \cdot 10^{-6} \text{ m}^3 \cdot \text{min}}$$

$$\underline{\underline{n = 1163 \text{ r.p.m.}}}$$

Calculation of the power rating  $p$  in Watts:

$$P = 2 \cdot \pi \cdot n \cdot M$$

$$p = 2 \cdot \pi \cdot 1163 \text{ r.p.m.} \cdot 1 \text{ Nm}$$

$$p = \frac{2 \cdot \pi \cdot 1163 \cdot 1}{60} \cdot \frac{\text{Nm}}{\text{s}}$$

$$\underline{P = 122 \text{ W}}$$

Calculation of the **torque** at the maximum input pressure:

$$p_{\text{max}} = 140 \cdot 10^5 \text{ Pa}$$

$$p = \frac{M}{V}$$

$$M = p \cdot V$$

$$M = 140 \cdot 10^5 \text{ Pa} \cdot 12.9 \cdot 10^{-6} \text{ m}^3$$

$$M = 140 \cdot 10^5 \cdot 12.9 \cdot 10^{-6} \frac{\text{N} \cdot \text{m}^3}{\text{m}^3}$$

$$M = 1806 \cdot 10^{-1} \text{ Nm}$$

$$\underline{M = 180.6 \text{ Nm}}$$

The mechanical-hydraulic and volumetric efficiency were not taken into account for the purposes of these calculations.

Hydraulic motors are generally designed in the same way as hydraulic pumps. They are divided up into:

- Constant motors  
fixed displacement
- Adjustable motors  
adjustable displacement

Both of these basic types includes several different designs.

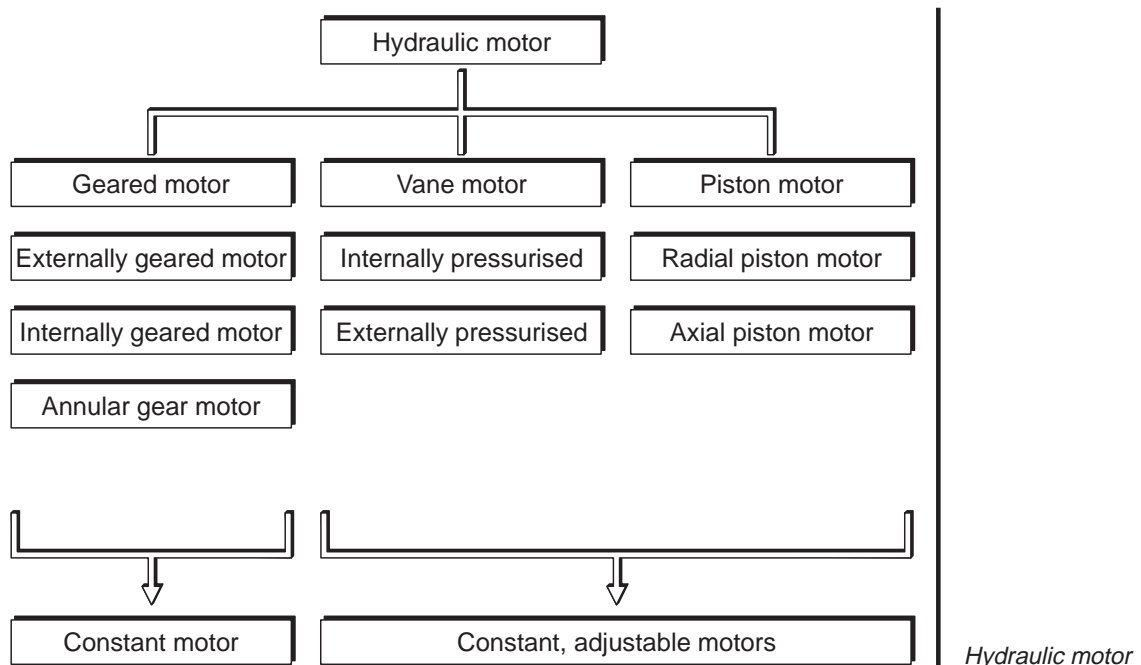





# **Chapter 15**

## **Accessories**

In addition to the hydraulic components described in the previous chapters – directional control valves, pressure valves, hydraulic cylinders, etc. – the following **accessories** are of importance for the functioning of a hydraulic system:

- flexible hoses
- quick-release couplings
- pipes
- screw fittings
- sub-bases
- air bleed valves
- pressure gauges and
- flow gauges.

These accessories are mainly used for transporting hydraulic energy (hoses, pipes, etc.), connecting and mounting components (screw fittings, sub-bases) and for implementing checking functions (gauges).

The components of a hydraulic system are connected together by means of hoses or pipes.

Flow cross-sections of **hoses** and **pipes** affect the pressure loss within the lines. To a large extent, they determine the efficiency of a system. To ensure that the pressure losses in the pipelines, elbows and bends and elbow connectors do not become too great and, at the same time, that the line dimensions are kept within certain limits, the system should be designed so that the following flow speeds are not exceeded:

Pressure lines:	up to 50 bar operating pressure 4.0 m/s
	up to 100 bar operating pressure 4.5 m/s
	up to 150 bar operating pressure 5.0 m/s
	up to 200 bar operating pressure 5.5 m/s
	up to 300 bar operating pressure 6.0 m/s
Suction lines:	1.5 m/s
Return lines:	2.0 m/s

The required flow cross-section is calculated on the basis of this data with the following formula:

$$A = \frac{Q}{v}$$

Q = flow rate

V = flow velocity

This equation can be used to determine the required size (diameter) of pipelines when sizing a hydraulic system.

**Calculations to determine the nominal size of lines:**

$$A = \frac{Q}{v} \quad \text{and} \quad A = \frac{\pi \cdot d^2}{4}$$

d = diameter

This results in the following equations for the nominal bore:

$$\frac{\pi \cdot d^2}{4} = \frac{Q}{v}$$

$$d^2 = \frac{4 \cdot Q}{\pi \cdot v} \quad d = \sqrt{\frac{4 \cdot Q}{\pi \cdot v}}$$

Technical Data

Example

Q = 4.2 dm<sup>3</sup>/min = 4.2 l/min Pressure line to 50 bar, v = 4 m/s

$$d = \sqrt{\frac{4 \cdot 4.2 \text{ dm}^3 / \text{min}}{\pi \cdot 4 \text{ m/s}}}$$

$$d = \sqrt{\frac{4 \cdot 4.2 \cdot 10^{-3}}{\pi \cdot 4 \cdot 60} \cdot \frac{\text{m}^3 / \text{s}}{\text{m/s}}} = \sqrt{0.022 \cdot 10^{-3} \text{ m}^2} = \sqrt{22 \text{ mm}^2}$$

d = 4.7 mm

**15.1 Flexible hoses** These are flexible line connections which are used between mobile hydraulic devices or in places where there is only limited space (particularly in mobile hydraulics). They are used in cases where it is not possible to assemble pipelines (e. g. on moving parts). Hoses are also used to suppress noise and vibration. They are made up of a number of layers:

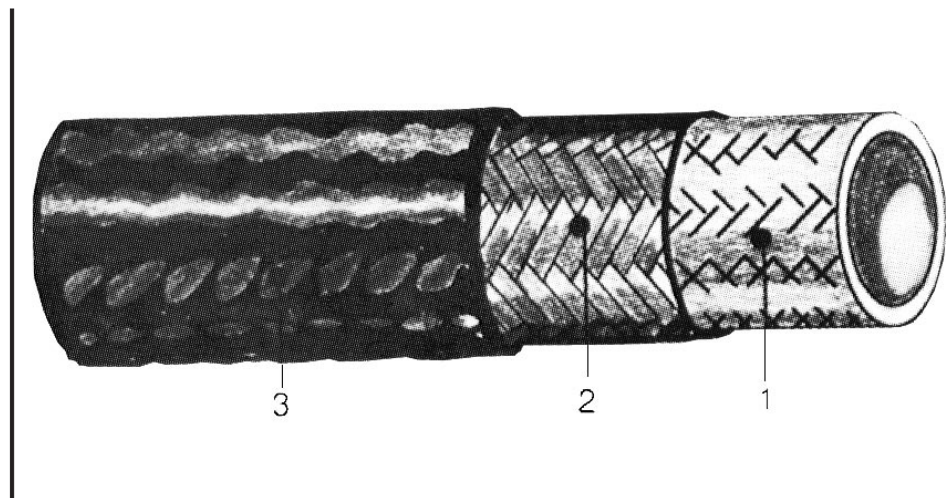

*Structure of the hydraulic hose*

The inner tube (1) is made of synthetic rubber, teflon, polyester-elastomer, perbunan or neoprene. The pressure carrier is a woven intermediate layer of steel wire and/or polyester or rayon.

This woven section (2) may consist of one or more layers depending on the pressure range.

The top layer (3) is made of wear-resistant rubber, polyester, polyurethane elastomer or other materials. The pipelines may be additionally protected against mechanical damage by external spirals or plaited material.

### Selecting flexible hoses

When deciding on flexible hoses, it is necessary to take into consideration their function and certain other factors.

In addition to power transmission by fluids, the hoses are subjected to chemical, thermal and mechanical influences. In particular, it is important to specify the operating pressure, both dynamic and static.

Pressures arising suddenly as a result of the fast switching of valves may be several times that of the calculated pressures.

As far as technical data such as nominal size, load, chemical and thermal resistance, etc. is concerned, only the manufacturer's specifications are definitive.

The recommendations regarding nominal size and pressure contained in DIN 20021, 20022 and 20023 should be observed. Testing instructions for flexible hoses are laid down in DIN 20024.

### Definitions of terms

- **Maximum permissible operating pressure**  
is specified by the manufacturer as far as static, and generally also dynamic, pressure is concerned. Static operating pressure is specified with a fourfold safety factor, i.e. operating pressure is 1/4 of bursting pressure.
- **Bursting pressure**  
This should be regarded purely as a test value. The hose will not burst or leak below this pressure.
- **Test pressure**  
Hoses are pressurised to double the operating pressure for at least 30 secs and at most 60 secs.
- **Change in length**  
Every hose changes in length to a certain extent at operating pressure, the extent of the change being dependent on the design of the woven intermediate layer. This change may not amount to more than +2% or less than -4%.
- **Bending radius**  
The specified minimum bending radius is intended for a stationary hose at maximum operating pressure. For reasons of safety, it is important not to fall below this minimum value.
- **Operating temperature**  
The specified temperatures refer to the oil passing through the system. High temperatures considerably reduce the service life of the hose.

The most important thing to ensure when installing flexible hoses is that the correct length of hose is used. It must be possible to move the parts without the lines being put under tension. In addition, the bending radii must be sufficiently large. The following diagram shows some basic rules on the assembly of hoses.

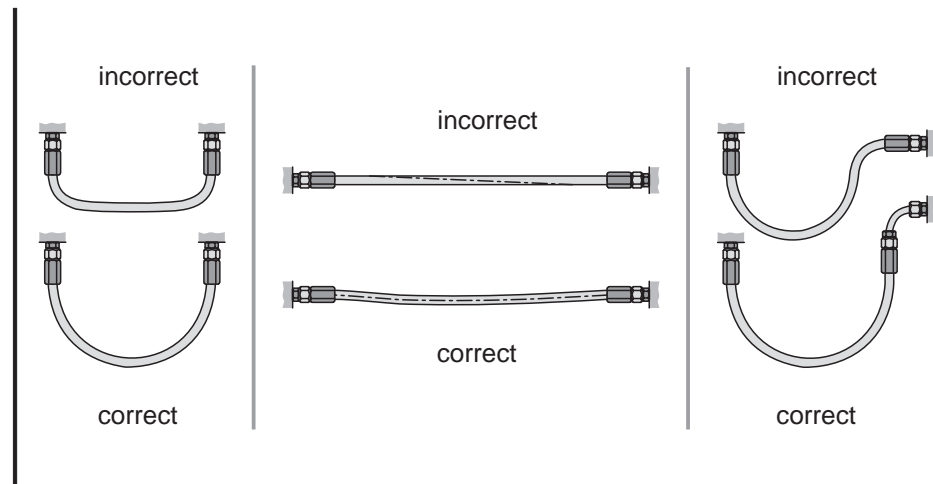

Installation of hose lines

Hoses are often used as connection components in mobile hydraulics and in many stationary systems. Therefore, it is necessary that the pressure drop  $\Delta p$  arising in the hoses is taken into consideration when sizing these systems.

$\Delta p$ in bar/m without connection fittings <span style="float: right;">(<math>\rho = 850 \text{ kg/m}^3</math>; <math>v = 20 \text{ mm}^2/\text{s}</math>)</span>											
NG	da (mm)	10 l/min	20	30	50	70	100	125	150	175	200 l/min
6	14	0.33	1.13	2.16							
	18	0.14	0.46	0.88							
8	16	0.10	0.31	0.59	1.41	1.2					
	20	0.045	0.12	0.23	0.55	0.97	0.82	1.2			
10	19	0.045	0.12	0.23	0.55	0.97	0.82	1.2			
	22	0.02	0.04	0.08	0.19	0.37	0.65	0.96	0.68	0.87	1.1
12	20	0.02	0.04	0.08	0.19	0.37	0.65	0.96	0.68	0.87	1.1
	26	0.008	0.02	0.03	0.075	0.15	0.27	0.39	0.57	0.73	0.92
16	26			0.01	0.041	0.07	0.14	0.2	0.27	0.35	0.43
	30				0.021	0.04	0.073	0.1	0.15	0.186	0.23
20	30				0.012	0.02	0.041	0.06	0.077	0.106	0.136
	34					0.013	0.025	0.035	0.05	0.06	0.083
24	36					0.009	0.016	0.023	0.032	0.04	0.051
	38.1						0.01	0.015	0.02	0.025	0.033
32	46						0.004	0.006	0.008	0.011	0.014
	50.8						0.003	0.004	0.005	0.007	0.009
40	60.3									0.003	0.004

*Flow resistance  $\Delta p$  of  
hose lines (Prof. Charchut)*

Hose lines may either be connected to the various pieces of equipment or else connected together by means of **screw fittings** or **quick connection couplings**. **Hose support connectors** ensure that connections do not affect operation:

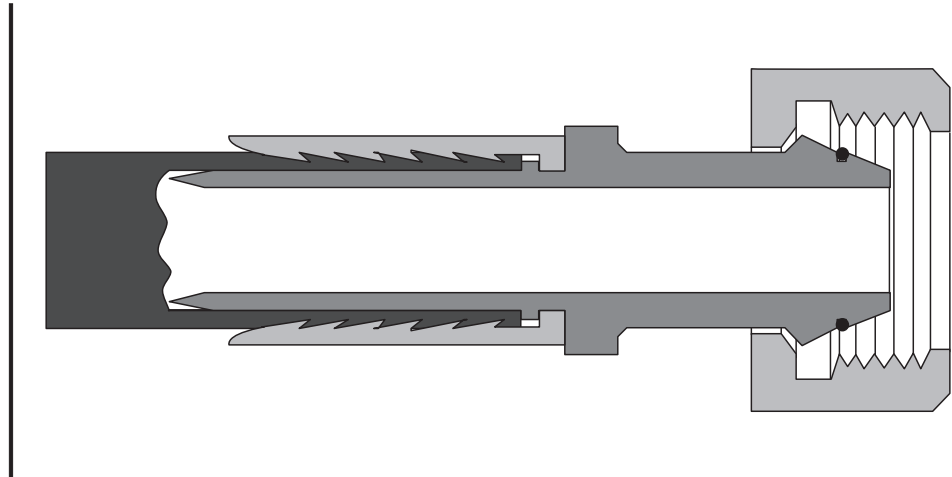

*Hose – connector*

DIN 24950 makes a distinction between the following mounting methods for the **hose side of the support connector**:

- **Screwed hose support connector**  
The support required by the hose is made by axial screwing together of individual parts. This hose fitting can generally be assembled without special tools and is re-usable.
- **Swaged hose support connector**  
The support required by the hose is achieved by distorting at least one connector support cone part. This hose fitting can only be assembled using special tools and is not re-usable.



- Sleeve support  
The support required by the hose is created using externally clamped sleeves or segments. This hose support is re-usable and can be assembled with or without special tools depending on type.
- Hose binding (hose clamp)  
The support required by the hose is achieved through bracing, e.g. using hose clamps as specified in DIN 3017 or tube straps as specified in DIN 32620. This hose support can be assembled either with or without special tools, depending on the design, and is in part re-usable – but is not, however, suitable for high pressures.
- Push-in hose support  
Usually made up of a nipple. The support required by the hose is generally achieved through the appropriate forming of the nipple. This hose support connector can be assembled without special tools and is re-usable. However, it is not suitable for high pressures.

DIN 24950 distinguishes between the following connections for the **connection side of the hose armature**:

- Screw connection  
provided with thread
- Pipe connection  
provided with pipe, for compression fittings
- Flange connection  
provided with flange
- Ring connection  
provided with ring
- Coupling connection  
provided with a symmetrical or asymmetrical coupling half
- Union connection  
provided with union

Connector nut

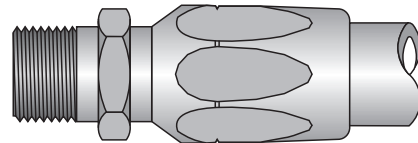

Pipe end

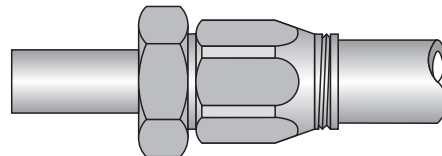

External thread

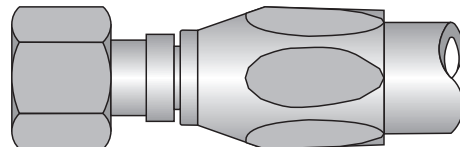



Nipple for SAE flange



*Hose support connection  
on connection side*

As shown in the diagram on page 264, the following components also form part of a hose support connector:

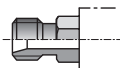
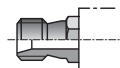
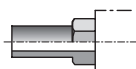
- Connector nut
- Sleeve  
The part of a hose support which encircles the hose. Distinction is made between screwed fixtures, swaged fixtures, clamping fixtures and hose clamps.
- Nipple insert (sleeve, tube support elbow)  
Component which is inserted into the hose forming the connection on the connection side. Even in the case of barbed fittings, DIN 24950 makes a distinction between a **connecting part on the hose side** and **one on the connection side**:
  - On the **hose side** of the fitting: screw-in, swaged and barbed fittings.
  - On the **connection side** of the fitting: threaded, sealing end, screw-in, pipe, collar, flanged and ring connections.

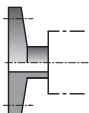
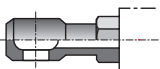
Nipple with sealing end connection		Diagram shows a sealing cone with O-ring
Nipple with threaded connection		
Nipple with screw-in connection		
Nipple with pipe connection		
Nipple with collar connection		
Nipple with flange connection		
Nipple with ring connection		

Hose support connectors – nipples

Quick-release couplings can be used for the fast connection and disconnection of devices.

These couplings are available both with and without a mechanically unlockable non-return valve. Where there is no pressure, connection is possible via the non-return valve without bleeding the hydraulic fluid.

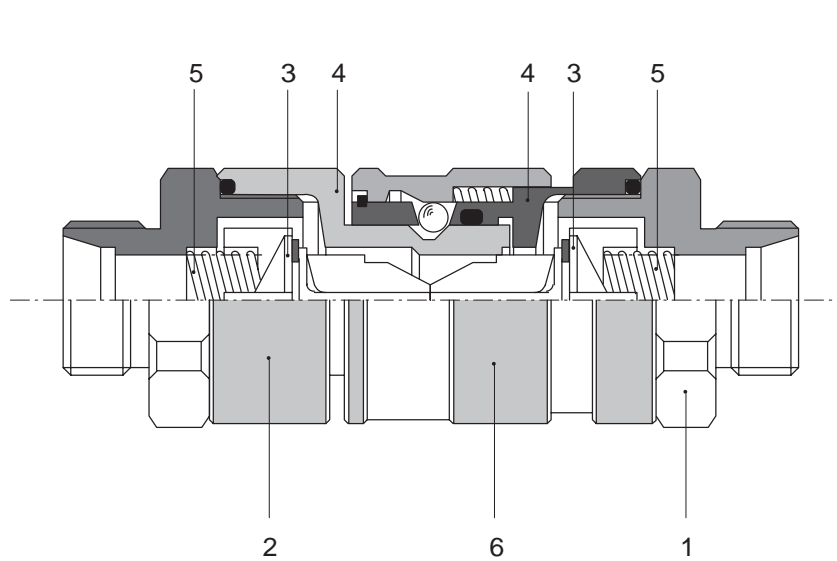

- |                         |                |
|-------------------------|----------------|
| 1 Quick coupling socket | 4 Sealing seat |
| 2 Coupling nipple       | 5 Spring       |
| 3 Sealing cone          | 6 Ring grip    |

Quick-release coupling

Seamless precision steel tubes are used as pipelines as specified in DIN 2391. The thickness of the walls of the pipelines is determined by the maximum pressure in the pipeline and a safety factor for control impacts.

## 15.2 Pipelines

Before installation, pipes can be bent either when cold or by being heated up using the appropriate bending devices. After being bent when hot, pipes should be cleaned to remove the scale layer formed during this procedure, for example.

The following components are suitable for pipe to pipe and pipe to device connection:

- Screwed pipe joints: up to nominal bore 38 (depending on operating pressure)
- Flanged connections: above nominal bore 30.

DIN 3850 distinguishes between the following screwed pipe joints:

- Solderless fittings
- Compression fittings
- Double conical ring screwed fittings
- Soldered and welded screwed fittings
- Brazed nipple type fittings
- Ball-type screw fittings

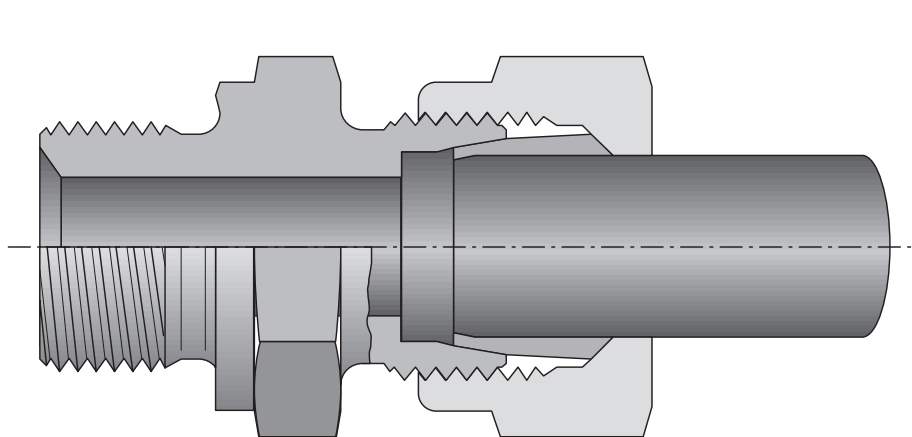

Screwed pipe joint

Owing to ease of use, the compression fitting is the most commonly used type of screwed fitting. When screwed together, a compression ring (olive) is pushed into the internal cone of the connector by tightening the connector nut. The olive is swaged into the pipe as it is pressed against a sealing stop.

Distinction is made in DIN 3850 between the following **sealing** and **connection components** for the specified pipe joints:

*Overview of sealing components*

Description	Defined in DIN
Compression ring	3816
Double conical ring	3862
Spherical-bush	3863
Flanged bushing	3864
Pressure ring	3867

*Overview of connection components*

Description		Defined in DIN	For sealing component
Connector nut	A B C	3870	Compression ring
			Double conical ring
			Soldered flanged bush
			Welded flanged bush
Connector nut		3872	Olive with pressure ring
Connector screw	A C	3871	Compression ring
			Double conical ring
			Spherical bush
			Flanged bushing

In addition, the following stub-end fittings are used with screwed pipe joints:

- straight connectors
- angle, L-, T- and soldered connectors.
- bulkhead fittings, welded hexagon nipples and brazed hexagon nipples

The specified types of connector are available in a number of different designs which are listed in DIN 3850. Specifications about nominal sizes and pressures for the standardised screwed pipe joints can also be found in DIN 3850.

**Flange connections** are also used for larger pipes. The flange may either be screwed or welded onto the pipe.

The diagram shows two flange connections, one for the pipe and one for the hose. B.S.F thread, metric fine thread and NPT (tapered thread) are commonly used in hydraulics as connecting threads.

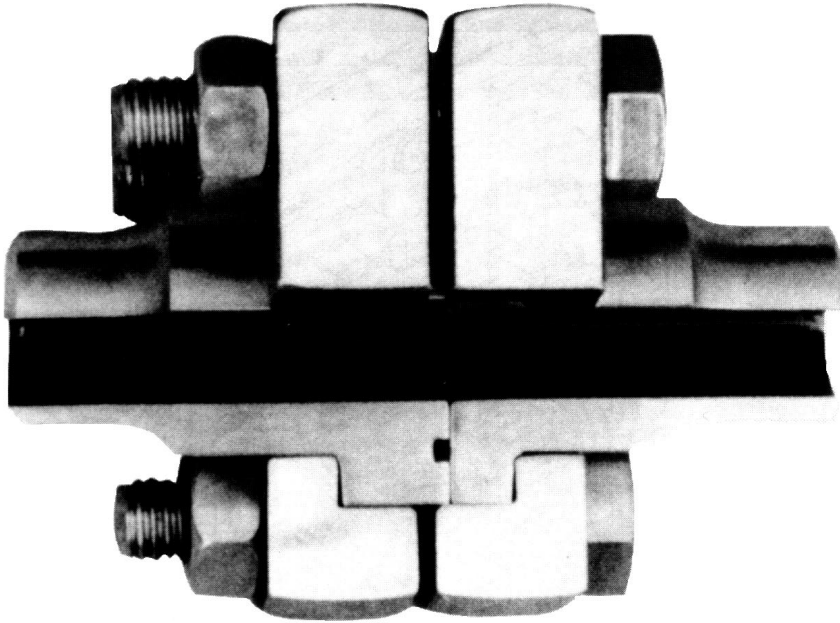

*Flange connection*

**15.3 Sub-bases** Direct connection of valves by means of pipes and hoses does not always fulfil requirements for a compact, economical and safe system. For this reason, sub-bases are commonly used in hydraulics for connecting equipment. This connection method allows fast valve exchanges. In addition, it reduces the flow paths of the hydraulic fluid. Like the valves, these sub-bases have standardised connection holes defined in DIN ISO 4401. The valves are screwed onto these bases and then mounted on front panels or valve supports and connected to hydraulic pipes on the reverse side.

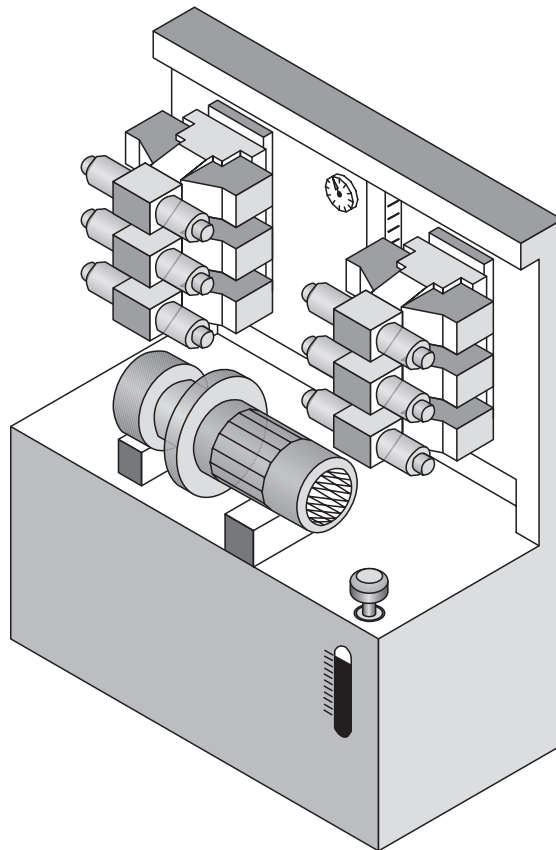

Front panel with tank  
and pump



To save piping costs, manifold blocks are used for valves switched in parallel (block hydraulics). Special control blocks of cast steel with the necessary connecting holes incorporated are manufactured for controls with repeated cycles, e.g. press controls, meaning that the valves simply need to be screwed on.

These special control blocks can be connected as required to form complex controls (interlinking of blocks).

### Vertical interlinking

Intermediate plate valves are connected together for vertical interlinking and screwed onto a common sub-base. As a result, only a limited amount of tubing is required.

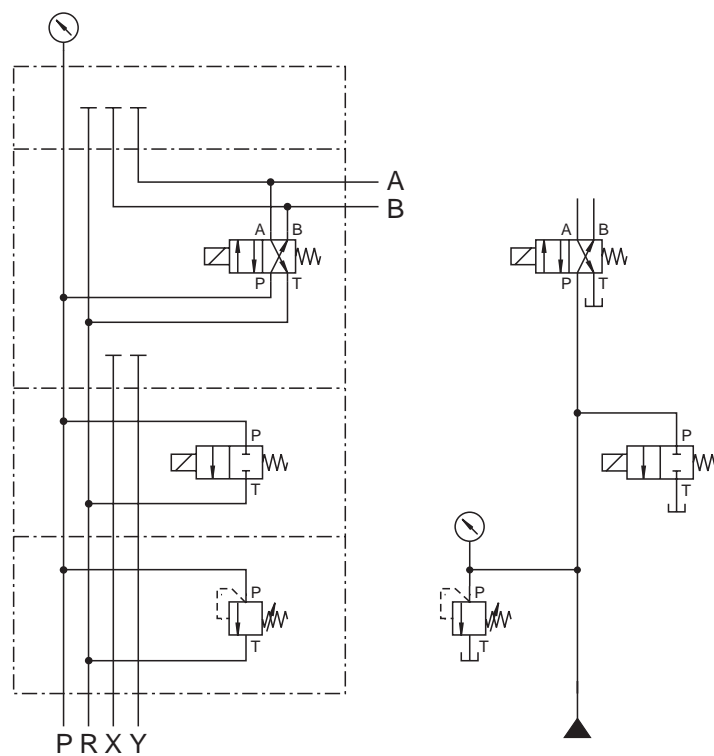

Standardised circuit diagram and vertical linking

**Longitudinal interlinking**

In systems with several control circuits, longitudinal plates are lined up separated by baffle plates. Either individual valves or a vertical valve arrangement can be screwed onto the baffle plate.

**Cartridge technology**

A further improvement with regard to the realisation of complete controls on a single block with compact multiple assembly has produced cartridge technology. With this method, the various control functions are realised by the individual activation of 2/2-way panel-mounted valves. The 2/2-way panel-mounted valves are standardised in DIN 2432. Panel-mounted valves (control blocks) only become economical from a nominal diameter of 16 mm upwards and with a larger numbers of items.

Bleed valves should be fitted at the highest point in a system of lines since this is where the trapped air collects.

The diagram shows an automatic bleed valve. Figures 1 to 3 illustrate the following phases:

**Fig. 1**

The cylinder has retracted, at the same time the piston of the bleed valve closes.

**Fig. 2**

When the piston rod extends, the piston of the bleed valve is lifted. The air is able to escape via the vent hole until the hydraulic fluid reaches the piston and pushes it upwards.

**Fig. 3**

With the cylinder extended, the piston of the bleed valve is pushed up as far as it can go by the hydraulic fluid, sealing off the outlet and closing off the air escape route. If the pressure falls, the spring releases the piston until the vent port is reopened and the process is repeated.

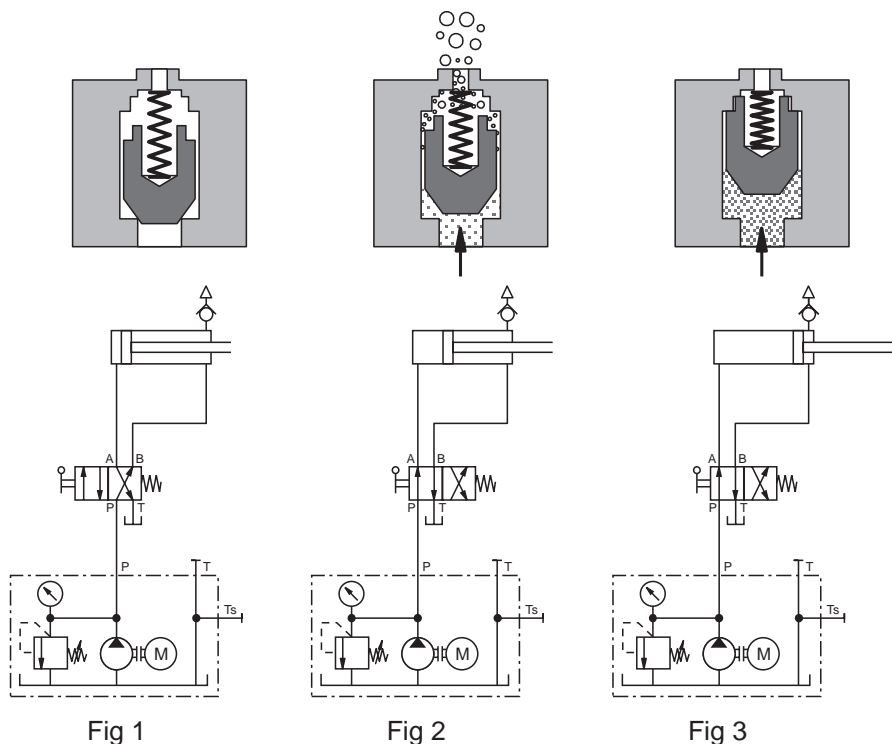

Automatic bleed valve

### 15.5 Pressure gauge Bourdon tube gauge

The most commonly used pressure gauge operates on the principle of the Bourdon tube. The curved Bourdon tube has a flat oval cross-section. When hydraulic fluid flows into the tube, an identical pressure is produced throughout. Owing to the difference in area between the outer curved surface and the inner curved surface, a greater force is produced at the outer area bending the Bourdon tube upwards. This movement is transferred to the pointer via the lever, rack segment and pinion. The pressure can then be read off the scale. This type of gauge is not protected against overpressure. A cushioning throttle must be installed in the inlet connection to prevent the spring being damaged by pressure surges. For pressures above 100 bar, a helicoid or screw-shaped Bourdon tube is used in place of the circular one. Pressures of up to 1000 bar can be measured. These gauges are sensitive with respect to their position and may only be installed in the position specified.

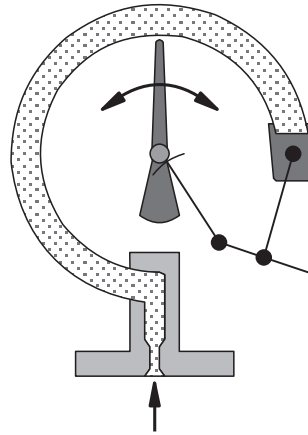

*Bourdon tube gauge*

**Diaphragm pressure gauge**

In these gauges, the Bourdon tube is replaced by a pressure-resistant capsule of corrugated metal or a pressure-resistant diaphragm clamped between two flanges. When the inside of the capsule or diaphragm is pressurised, it is deflected. This amount of the deflection determines the pressure being measured and is transferred to the pointer via a mechanism. The pressure range is dependent on design and may go up to 25 bar.

**Piston pressure gauge**

In the piston pressure gauge, the hydraulic fluid operates on a piston, the forces of which work against a pressure spring. The pointer is directly connected to the piston which displays the relevant pressure at the gauge. Piston pressure gauges are protected against overloading.

**15.6 Pressure sensors**

More precise pressure measurements are possible with quartz pressure sensors which exploit the piezo-electric effect. In these sensors, the pressure operates on a diaphragm and, consequently, on the quartz crystal which emits an appropriate voltage or current when under pressure. This electrical signal is electronically amplified and displayed by an evaluating device in the form of a measurement of pressure.

Other types of pressure sensor operate with strain gauges which are arranged on a diaphragm. Under pressure the diaphragm is deformed. The stretching of the gauge resulting from this is converted into electrical signals. These signals are again electronically amplified and displayed by a separate piece of equipment. In the case of these sensors, the electronic section controlling this amplification is integrated directly into the housing.

Advantages of electronic pressure sensors: The pressure which is displayed can be evaluated at remote points by connection cables or recorded by operation recorders. Direct activation of pressure valves via the amplifier is also possible.

**Volumetric flow gauges**

If a single measurement is required in order to check the pump delivery or to set a flow control valve, the simplest method of checking the volumetric flow rate is to use a measuring container and a stop watch.

If the flow rate in a hydraulic system is to be continually monitored and displayed, one of the devices on the following pages should be selected to suit requirements for application and precision.

The hydraulic flow to be measured passes through a measuring tube. A fixed cone is located in the measuring tube, which can be acted upon by a piston. If the hydraulic fluid flows through the gauge between the cone and the piston, the piston is pressed against a spring according to the rate of flow. The piston serves as a mobile orifice. A flow cross-section is produced corresponding to its position on the cone. The piston moves until the set pressure difference which moves the piston against the spring is in equilibrium. As the flow rate is dependent on the pressure difference at the orifice, the displacement of the piston can be displayed as a measure of the flow rate. The display error is in the range of 4%.

### 15.7 Flow measuring instruments

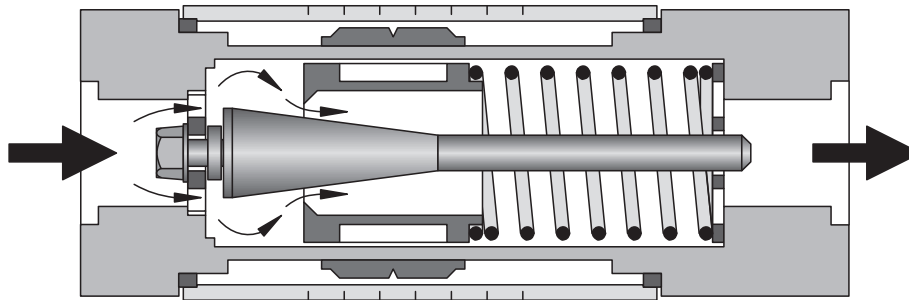

Flow meter  
(works diagram UCC)

**Measuring turbines, oval disk meters, gear meters, orifice gauges and retarding disks** are used for more precise measurements for the regulation or control of synchronous cylinders or motors and for positioning control.

The rotor or turbine is set in rotation by the flow rate. The speed is evaluated as a measurement of flow rate and displayed (diagram).

The gear meter is constructed like a gear motor. Each tooth is inductively sensed by a measuring device. The speed is shown via a transducer in the form of a flow rate.

The oval disk meter operates by the same principle. Once again, the speed is measured inductively. Since, as in the case of the gear meter, the chamber volume is known, the flow rate can be calculated from the speed which is measured.

In the case of the orifice gauge, the  $\Delta p$  is measured, electronically converted and displayed as a flow rate.

The baffle plate operational principle is as follows: the flow rate acts on a baffle plate located in the flow pipe which executes a stroke in accordance with the value of the flow rate. The stroke length is contactlessly sensed. The electrical output signal is converted and displayed as a flow rate.

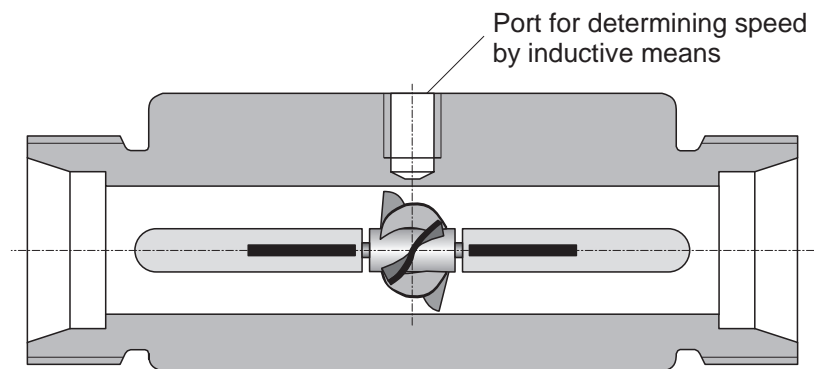

*Turbine meter*



# Chapter 16

## Appendix



In hydraulics, the pressure unit bar is generally used owing to the high pressures which arise. The international system of units SI (Système International) specifies the use of the pressure units Pascal and, with certain reservations, bar; the units atm and Torr are to be avoided.

$$1 \text{ Pascal} = 1 \text{ Pa} = 1 \frac{\text{N}}{\text{m}^2} = 10^{-5} \text{ bar}$$

	Pa	bar	mbar	Torr	at
1 Pa = 1 N/m <sup>2</sup>	1	10 <sup>-5</sup>	10 <sup>-2</sup>	7.5 • 10 <sup>-3</sup>	1.02 • 10 <sup>-5</sup>
1 bar = 10 N/cm <sup>2</sup>	10 <sup>5</sup>	1	103	750	1.02
1 mbar = 1 N/dm <sup>2</sup>	100	10 <sup>-3</sup>	1	0.75	1.02 • 10 <sup>-3</sup>
1 Torr = 1 mm Hg	1.33 • 10 <sup>2</sup>	1.33 • 10 <sup>-3</sup>	1.33	1	1.36 • 10 <sup>-3</sup>
1 at = 1 kp/cm <sup>2</sup>	0.981 • 10 <sup>5</sup>	0.981	0.981 • 10 <sup>3</sup>	736	1

*Conversion of pressure units (values have been rounded off) DIN 1314 (12.71)*

$$5\,000 \text{ kPa} = ? \text{ bar}$$

Example

$$p = 5\,000 \text{ kPa} \quad \frac{\text{mbar}}{\text{Torr}}$$

$$p = 5\,000\,000 \text{ Pa}$$

$$p = 5\,000\,000 \cdot 10^{-5} \text{ bar}$$

$$p = \frac{5\,000\,000}{100\,000} \text{ bar}$$

$$\underline{p = 50 \text{ bar}}$$

**Safety regulations** For hydraulic systems, we advise you to adhere to the technical safety specifications laid down in DIN 24346. The accident prevention specifications (VBG) of the Employer's Liability Insurance Association which are relevant for both individual machines and complete systems, e.g. "Hydraulic presses" (VBG 7n5.2; UVV 11.064), should also be taken into consideration.

Some other important safety principles are listed below:

- Never operate a system or press a switch if you are unaware of its function.
- Do not switch on the power supply until all lines are connected up. Important: check whether all return lines (leakage pipes) lead to the tank.
- Before commissioning, carefully flush the system. Then, change the filter elements. On initial commissioning of the system, open the system pressure relief valve almost completely and slowly adjust the system to the operating pressure. Pressure relief valves must be installed in such a manner that they cannot become ineffective.
  
- All setting values must be known.
- Bleed the system and the cylinders.
- Install the Emergency Stop switch in a position where it is easily reached.
- Use only standard parts.
- Incorporate all changes into the circuit diagram without delay.
- Nominal pressure must be clearly indicated.
- Check that the devices installed in the system are permissible for the maximum operating pressure.
- Suction lines must be designed in such a way as to eliminate the possibility of air being taken into the system.
- The temperature of the oil in the intake line to the pump must not exceed 60 °C.
- The cylinder piston rods must not be bent; they must not be subjected to lateral forces.
- Protect piston rods against damage and dirt.

Particular care should be taken in the use of hydraulic reservoirs:

- Before commissioning the reservoir, the manufacturer's specifications should be studied.
- The hydraulic lines to the reservoir must be carefully bled. This can usually be accomplished at the safety and shut-off block of the reservoir.
- Repair work to hydraulic systems can only be carried out after releasing the oil pressure to the reservoir. Where possible, separate the reservoir from the system (by means of a valve).
- Never drain off the contents of the reservoir unthrottled!
- For details regarding installation and operation, see "Technical Specifications for Pressure Reservoirs" (TRB).
- All hydraulic reservoirs are subject to the pressure reservoir standards.

