

# Electrohydraulics

## Basic Level



Workbook TP 601



#### Authorised applications and liability

The Learning System for Automation and Communication has been developed and prepared exclusively for training in the field of automation and communication. The training organization and / or trainee shall ensure that the safety precautions described in the accompanying Technical documentation are fully observed.

Festo Didactic hereby excludes any liability for injury to trainees, to the training organization and / or to third parties occurring as a result of the use or application of the station outside of a pure training situation, unless caused by premeditation or gross negligence on the part of Festo Didactic.

Order no.:	094470
Description:	TEACHW. E-HYDR.
Designation:	D.S601-C-SIBU-GB
Edition:	07/2003
Layout:	04.07.2003, OCKER Ingenieurbüro
Graphics:	OCKER Ingenieurbüro
Author:	D. Merkle, H. Werner

© Festo Didactic GmbH & Co. KG, 73770 Denkendorf, Germany, 2003

The copying, distribution and utilization of this document as well as the communication of its contents to others without expressed authorization is prohibited. Offenders will be held liable for the payment of damages. All rights reserved, in particular the right to carry out patent, utility model or ornamental design registrations.

Parts of this training documentation may be duplicated, solely for training purposes, by persons authorised in this sense.

## Preface

Festo Didactic's Learning System for Automation and Communications is designed to meet a number of different training and vocational requirements. The Training Packages are structured accordingly:

- Basic Packages provide fundamental knowledge which is not limited to a specific technology.
- Technology Packages deal with the important areas of open-loop and closed-loop control technology.
- Function Packages explain the basic functions of automation systems.
- Application Packages provide basic and further training closely oriented to everyday industrial practice.

Technology Packages deal with the technologies of pneumatics, electropneumatics, programmable logic controllers, automation with PCs, hydraulics, electrohydraulics, proportional hydraulics and application technology (handling).

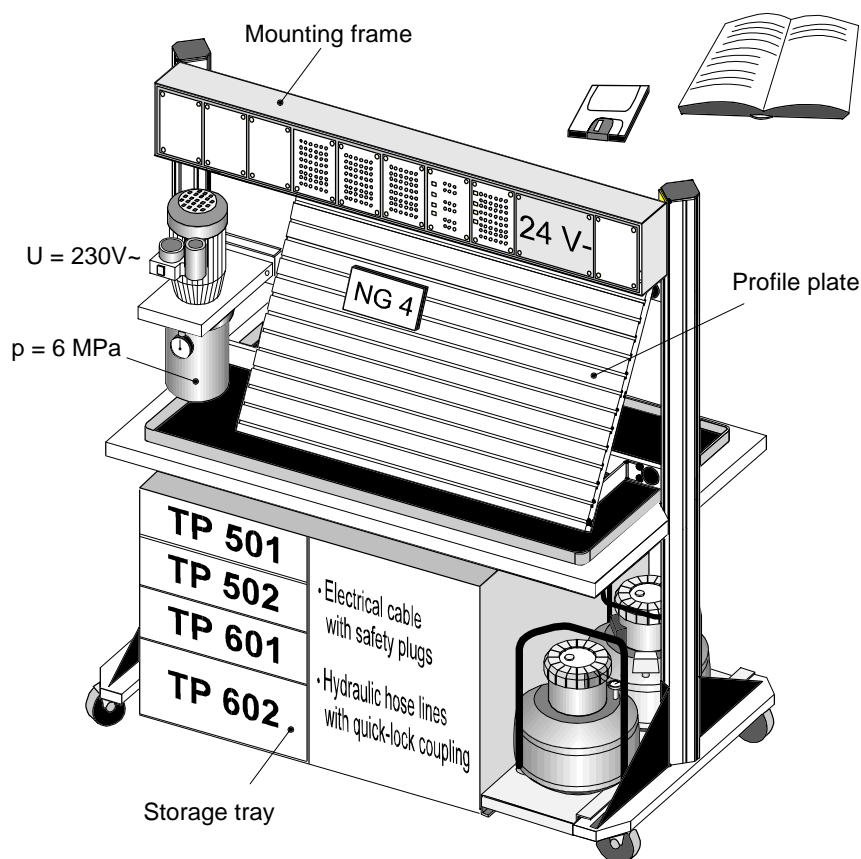

Fig. 1  
Example of  
Hydraulics 2000:  
Mobile laboratory trolley

The modular structure of the Learning System permits applications to be assembled which go beyond the scope of the individual packages. It is possible, for example, to use PLCs to control pneumatic, hydraulic and electrical actuators.

All training packages have an identical structure:

- Hardware
- Courseware
- Software
- Courses

The hardware consists of industrial components and installations, adapted for didactic purposes.

The courseware is matched methodologically and didactically to the training hardware. The courseware comprises:

- Textbooks (with exercises and examples)
- Workbooks (with practical exercises, explanatory notes, solutions and data sheets)
- OHP transparencies, electronic transparencies for PCs and videos (to bring teaching to life)

Teaching and learning media are available in several languages. They have been designed for use in classroom teaching but can also be used for self-study purposes.

In the software field, CAD programs, computer-based training programs and programming software for programmable logic controllers are available.

Festo Didactic's range of products for basic and further training is completed by a comprehensive selection of courses matched to the contents of the technology packages.

Latest information about the technology package **TP601**.

New in Hydraulic 2000:

- Industrial components on the profile plate.
- Exercises with exercise sheets and solutions, leading questions.
- Fostering of key qualifications:  
Technical competence, personal competence and social competence form professional competence.
- Training of team skills, willingness to co-operate, willingness to learn, independence and organisational skills.

Aim – **Professional competence**

### **Content**

Part A	Course	Exercises
Part B	Fundamentals	Reference to the text book
Part C	Solutions	Function diagrams, circuits, descriptions of solutions and equipment lists
Part D	Appendix	Storage tray, mounting technology and datasheets



## **Table of contents**

Introduction	11
Notes on safety	13
Notes on operation	14
Technical notes	15
Training contents	21
Training aims/exercise table (Table 1)	22
Equipment set for Basic Level TP 601	23
Equipment set for Advanced Level TP 602	26
List of additional components for TP600	27
Component/exercise table (Table 2)	28
Methodological structure of exercises	29

## **Part A – Course**

### **Simple control circuits without limit switches**

Exercise 1: Sorting device Double-acting cylinder, directly actuated, manually	A-3
Exercise 2: Component selection on conveyor belt Double-acting cylinder, indirectly actuated, manually	A-13
Exercise 3: Lifting station Single-acting cylinder, indirectly actuated, manually	A-23
Exercise 4: Bending device Double-acting cylinder, latching	A-29
Exercise 5: Press-fitting device Double-acting cylinder, latching, return stroke using pressure switch	A-33

Exercise 6:	Stamping machine Double-acting cylinder, differential circuit	A-39
Exercise 7:	Door control Double-acting cylinder, interlock, INCHING operation	A-43

### ***Control circuits with limit switches***

Exercise 8:	Machining unit Differential circuit return stroke using limit switch	A-49
Exercise 9:	Feed for drilling machine Rapid-traverse feed circuit, speeds controlled by limit switch	A-53
Exercise 10:	Press Pressure control circuit with limit switch and pressure switch	A-59
Exercise 11:	Feed device Pressureless pump bypass with limit switch	A-63

### ***Control circuits with two actuators***

Exercise 12:	Assembly device Pressure-dependent sequence control with cylinder and hydraulic motor	A-69
Exercise 13:	Lifting device for packages Position-dependent sequence control with two cylinders	A-75



## **Part B – Fundamentals**

### **Teil C – Solutions**

Solution 1: Sorting device	C-3
Solution 2: Component selection on conveyor belt	C-7
Solution 3: Lifting station	C-11
Solution 4: Bending device	C-15
Solution 5: Press-fitting device	C-19
Solution 6: Stamping machine	C-23
Solution 7: Door control	C-27
Solution 8: Machining unit	C-33
Solution 9: Feed for drilling machine	C-39
Solution 10: Press	C-45
Solution 11: Feed device	C-49
Solution 12: Assembly device	C-55
Solution 13: Lifting device for packages	C-61

### **Part D – Appendix**

Storage tray	D-2
Mounting systems	D-3
Sub-base	D-5
Coupling system	D-6
Data sheets	...



## ***Introduction***

This workbook forms part of Festo Didactic's Learning System for Automation and Communications. The Training Package TP 600 is designed to provide an introduction to the fundamentals of electrohydraulic control technology. This package comprises a basic level and an advanced level. The basic level package TP 601 teaches basic knowledge of electrohydraulic control technology. The equipment sets TP 601 and TP 602 (for the advanced level) provide the student with the key qualification "Technical competence".

The hydraulic components have been designed to provide the following:

- Easy handling
- Secure mounting
- Environmentally-friendly coupling system
- Compact component dimensions
- Authentic measuring methods

You will require the following for the practical execution of the exercises:

- A Festo Didactic profile plate or a laboratory trolley
- An equipment set TP 601 (cylinders, valves, relay plate, ...)
- A hydraulic power pack
- A number of hydraulic hose lines
- An electrical power supply unit
- A set of electrical cables

The Training Package TP 601 specifies fundamental training contents. These help develop both technical and methodological competence in electrohydraulics:

- Physical interrelationships in electrical engineering and hydraulics
- Drafting, assembly and understanding of basic electrohydraulic circuits
- Comparison of the use of various valves and other components
- Development of alternative solutions

The technical requirements for safe operation of the components are as follows:

- A hydraulic power pack to provide an operating pressure between 0.5 and 6 Mpa (5 to 60 bar) and a flow rate of 2 l/min.
- An electrical power supply for the above of 230 V AC, 50 Hz, with a 10 A fuse.
- A short-circuit-proof electrical power supply for the electrical components with an output of 24 V DC and a 3 A fuse.
- A profile plate to mount the components  
The profile plate (1100 x 700 mm) has 14 parallel T-grooves at intervals of 50 mm.

This workbook has been developed for use in the “Dual system” of vocational training. It is, however, equally suitable for use in providing a practical introduction to electrohydraulics for students at universities and technical colleges. The modular design of the hardware allows theoretical questions to be dealt with experimentally in a simple and efficient form.

The theoretical background to facilitate understanding of this workbook is provided in the textbook

Learning System for Automation and Communications

■ **Electrohydraulics** Basic Level

Festo Didactic also offers the following further training materials for hydraulics:

- Sets of OHP transparencies and electronic transparencies for PCs
- Linear videos and interactive videos (video discs)
- Autosketch CAD software and symbol library
- Hydraulics simulation program for planning, simulation and visualisation (in course of preparation)
- Sets of magnetic symbols and symbols for OHPs, hydraulic slide rule
- Transparent models for OHPs, with special hydraulic power pack
- Equipment sets: BIBB, hand-lever hydraulics, proportional hydraulics, closed-loop hydraulics, measurement kit in case

Please see our special brochures for a detailed description of further training materials.

### ***Notes on safety***



Observe the following in the interests of your own safety:

- **Caution!**  
Cylinders may move unexpectedly when the hydraulic power pack is switched on.
- Do not exceed the maximum permissible hydraulic operating pressure. See the relevant data sheets.
- Do not operate electrical limit switches directly by hand when carrying out fault-finding. Use a tool for this.
- Use only an extra-low voltage of 24 V to operate the components.
- Observe all general safety instructions.



## **Notes on operation**

### **Assembly**

Always work in the following sequence when assembling or dismantling an electrohydraulic circuit.

1. The hydraulic power pack and electrical power supply must be switched off during the assembly of the circuit.
2. All components must be securely fitted to the profile plate or mounting frame.
3. Connect up the hydraulic hose lines.  
All valves, other components and hose lines are fitted with self-closing quick-acting couplings. Do not exceed the maximum permissible pressure of 12 MPa (120 bar). The maximum operating pressure is 6 MPa (60 bar).
4. Connect up the electrical cables.  
Connect test leads to the component sockets by means of 4 mm plugs.
5. Before commissioning a hydraulic control circuit, check that all return lines are connected and that all connectors are secure.
6. Switch on the electrical power supply first and then the hydraulic power pack.
7. Commissioning the control circuit
  - Press the START pushbutton
  - Set components, etc.
  - Compare what you have assembled with the description in the book.

### **Dismantling**

8. Before dismantling the circuit, ensure that pressure in hydraulic components has been released:

**Couplings must be disconnected only under zero pressure!**

9. Switch off the hydraulic power pack first and then the electrical power supply.

## Technical notes

Observe the following in order to ensure safe operation.

- The hydraulic power pack incorporates an adjustable pressure relief valve. In the interests of safety, the pressure is limited to approx. 6 MPa (60 bar). Every time a control circuit is assembled on the profile plate, a second pressure relief valve is used. We recommend that this should be set to a maximum pressure of 5 MPa (50 bar).
- All valves, cylinders and hose lines are fitted with quick-acting couplings which ensure minimum leakage. The maximum pressure for all components in the training package is 12 MPa (120 bar). Thanks to their design, the couplings reduce leakage during connection and disconnection to a minimum.

**The operating pressure should not exceed 6 MPa (60 bar)**

- In the case of double-acting cylinders, the pressure intensification effect may produce an increased pressure proportional to the area ratio of the cylinder. With an area ratio of 1:1.7 and an operating pressure of 6 MPa (60 bar), this increased pressure may be over 10 MPa (100 bar)!

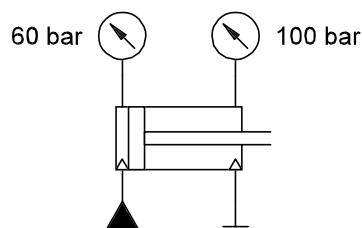

Fig. 2:  
Pressure intensification

- If connections are detached under pressure, the non-return valve in the coupling may cause pressure to become trapped in the valve or other component concerned. The pressure relief device can be used to release this pressure. Exception: This is not possible in the case of hose lines and non-return valves. Ensure therefore that control circuits are depressurised before hose lines are disconnected and the circuit is dismantled.
- All valves, other components and hose lines are fitted with self-closing quick-acting couplings. This prevents the accidental spillage of hydraulic fluid. In the interests of simplicity, these couplings are not shown in circuit diagrams.

Fig. 3:  
Simplified representation  
in circuit diagrams



Throttle

Hose

Shut-off valve

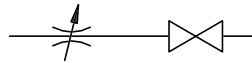



**Symbolic representation of directional control valves**

Valves are shown in the “Circuit diagram, hydraulic” in essentially the same way as in the textbook. The crossover position is on the right and the parallel position on the left. Working port A is, however, on the right, and port B is therefore on the left. This symbolic representation conforms to the new “Hydraulics 2000” hardware.

The drawing “Practical assembly, hydraulic” is based on the symbol on the valve. The crossover position is on the left and the parallel position on the right. Working port A is now on the left and port B on the right. This symbolic representation is hardware-oriented.

The two different symbolic representations describe all functions of a given valve. In practice, valves by different manufacturers with identical functions are sometimes given different symbols. This is permitted by the applicable standard, DIN ISO 1219 Part 1, of November 1993 with the title “Fluidics: Graphic Symbols and Circuit Diagrams”.

	<i>Circuit diagram, hydraulic</i>	<i>Practical assembly, hydraulic</i>	<i>Representation of directional control valves</i>
4/2-way solenoid valve			
4/3-way solenoid valve in mid-position			

Since hydraulic valves are very expensive, only a small number of these and only a small number of different types are used in the equipment set.

The 4/2-way valve can be used to produce four further basic functions.

	<i>Basic function in "Circuit diagram, hydraulic"</i>	<i>Connection of 4/2-way solenoid valve in "Practical assembly, hydraulic"</i>
2/2-way valve with closed in neutral position		
2/2-way valve with flow in neutral position		
3/2-way valve with closed in neutral position		
3/2-way valve with flow in neutral position		

Ports on the directional control valve which are not required are sealed by the self-closing coupling nipples. It is not necessary to seal these ports by means of plugs.

The 4/3-way valve with closed mid-position fulfils various different functions in the exercises in this book.

	<i>Function of solenoid valves in "Circuit diagram, hydraulic"</i>	<i>Connection of 4/3-way solenoid valve in "Practical assembly, hydraulic"</i>
No electrical connection is made to solenoid 1Y2		
Solenoid 1Y2 must be activated in "Practical assembly, electrical" via an additional path.		
No electrical connection is made to solenoid 1Y2.  or  No electrical connection is made to solenoid 1Y1		

## Electrical

Power supply:  
230 VAC, 50 Hz

- The hydraulic power pack is protected by a 10 A fuse.
- The short-circuit proof electrical power supply has a 3 A fuse.
- The output voltage of this power supply is 24 V DC.
- The output current is limited to a maximum of 4.5 A.

Wiring:

Universal cable set: 61 red and 37 blue laboratory cables in 5 lengths. All electrohydraulic components are equipped with 4 mm sockets. The electrical connections for these components are made using the laboratory cables with 4 mm plugs.

A distinction should be made between the two designs of electrical limit switches:

- Electrical limit switch, actuated from the **left**.
- Electrical limit switch, actuated from the **right**.
- When cylinder piston speeds are high, the limit switches should be actuated by cylinder cams only in the specified direction.
- Limit switches must not be actuated from the front.
- Both types of limit switches are shown by the same symbol in the hydraulic and electrical circuit diagrams.

## **Training contents**

- Basic physical principles of electrical engineering and hydraulics
  - Function and use of electrical and electrohydraulic components such as switches, pushbuttons and solenoid valves
  - Naming and identifying electrical and hydraulic symbols
  - Development and reading of standard circuit diagrams
  - Representation of control exercises as function diagrams
  - Drafting, assembly and commissioning of basic circuits
  - Direct and indirect activation of cylinders
  - Activation of a hydraulic motor
  - MANUAL and AUTOMATIC modes
  - Position and pressure dependent control circuits
  - Interlock circuit
  - Rapid-traverse circuit
  - Fault-finding with simple electrohydraulic control circuits
- Basic Level  
(TP601)*
- 
- Function and use of electronic sensors, hydraulic motors and hydraulic accumulators
  - Complex sequence controls
  - Combination position and pressure dependent control circuits
  - Electrical control circuit with several actuators
  - Sequence controls with MANUAL/AUTOMATIC, EMERGENCY STOP and SETTING modes
  - Circuit with hydraulic accumulator
  - Position and time dependent control circuits
  - Systematic fault-finding in electrohydraulic control circuits
  - Development of sequence controls from a function diagram
  - Controls with timer relays with pick-up and drop-off delays
  - Counter controls with predetermining counters
- Advanced Level  
(TP602)*

**Training aims/exercise table (Table 1)**

List of training aims	Training aims	Exercise												
		1	2	3	4	5	6	7	8	9	10	11	12	13
	Actuation of double-acting cylinders	•	•		•	•	•	•	•	•	•	•	•	•
	Actuation of single-acting cylinders			•										
	Actuation of a hydraulic motor												•	
	Direct actuation	•												
	Indirect actuation		•	•	•	•	•	•	•	•	•	•	•	•
	Control circuit operated manually	•	•	•										
	Control circuit with latching				•	•								
	Use of a pressure switch					•					•		•	
	Production of a differential circuit						•		•					
	Interlock circuit							•						
	INCHING operation							•						
	Use of limit switches								•	•	•	•	•	•
	Rapid-traverse feed circuit									•	•			
	Pressureless pump bypass												•	

## Equipment set for Basic Level TP 601







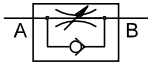

This equipment set has been compiled for use in basic training in electrohydraulic control technology. The set can be combined in any desired way with other equipment sets from the Festo Didactic Learning System.

<i>Description</i>	<i>Order No.</i>	<i>Qty.</i>
Pressure gauge	152841	3
One-way flow control valve	152843	1
Non-return valve, 1 bar	152845	1
Non-return valve, 5 bar	152846	1
Branch tee	152847	8
Pressure relief valve, pressure sequence valve	152848	2
2-way flow control valve	152851	1
Non-return valve, piloted	152852	1
Double-acting cylinder, 16/10/200	152857	1
Hydraulic motor, 8 l/min	152858	1
Loading weight, 9 kg	152972	1
Relay, 3-fold*	162241	2
Signal input unit, electrical*	162242	1
Indicator and distributor unit, electrical *	162244	1
4/2-way solenoid valve	167082	1
4/3-way solenoid valve closed in mid-position	167083	1
Limit switch, electrical, actuated from the right	183322	2
Limit switch, electrical, actuated from the left	183345	2
<i>We recommend</i>	<i>Order No.</i>	<i>Qty.</i>
Hose line with quick-release coupling, 600 mm	152960	10
Hose line with quick-release coupling, 1000 mm	152970	8

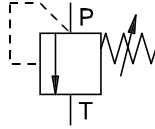
Order No.: 184463 for equipment set TP 601

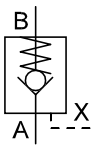
\* These components can be mounted in the mounting frame or, by using the adapter set (Order No. 35651), on the profile plate.

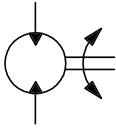
*Symbols for  
equipment set TP 601*

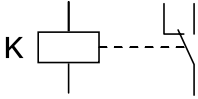
<p>Pressure gauge</p> 	<p>One-way flow control valve</p> 
<p>Non-return valve, 1 bar resp. 5bar</p> 	<p>Pressure relief valve, pressure sequence valve</p> 
<p>2-way flow control valve</p> 	<p>Non-return valve, piloted</p> 
<p>Double-acting cylinder, 16/10/200</p> 	<p>Hydraulic motor, 8 l/min</p> 
<p>Weight, 9 kg</p> 	<p>Relay, 3-fold</p> 



Signal input unit, electrical

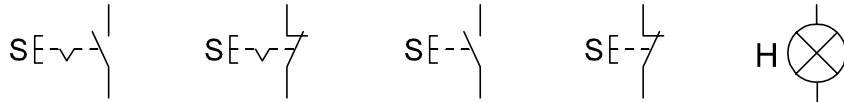

Symbols for equipment set TP 601

Indicator and distributor unit, electrical



Limit switch, electrical, actuated from the left or from the right

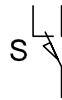

4/2-way solenoid valve

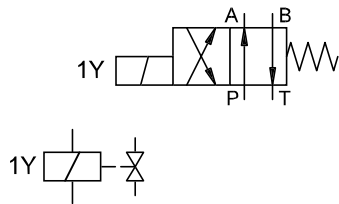

4/3-way solenoid valve closed in mid-position

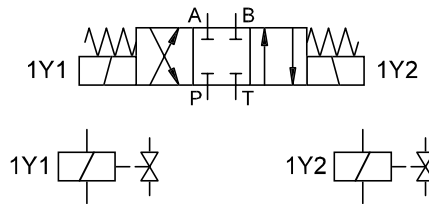

### **Equipment set for Advanced Level TP 602**

This equipment set has been compiled for advanced-level teaching of electrohydraulic control technology. The two equipment sets TP 601 and TP602 can be expanded in any desired way with other equipment sets from Festo Didactic's Learning System for Automation and Communications.

Order No.: 184464  
for equipment set TP 602

<i>Description</i>	<i>Order-No.</i>	<i>Qty.</i>
Relay, 3-fold*	162241	2
Timer relay, 2-fold*	162243	1
Predetermining counter, electrical, additive *	162355	1
Indicator and distributor unit, electrical *	162244	1
Pressure switch	167080	1
Branch tee	152847	4
Pressure relief valve, piloted	152849	1
3-way pressure reducing valve	152850	1
4/2-way solenoid valve	167082	1
Double-acting cylinder, 16/10/200	152857	1
Diaphragm accumulator with shut-off block	152859	1
EMERGENCY STOP, electrical	183347	1
Proximity switch, inductive	178574	1
Proximity switch, capacitive	178575	1
Proximity switch, optical	178577	1

<i>We recommend:</i>	<i>Order-No.</i>	<i>Qty.</i>
Hose line with quick-release coupling, 600 mm	152960	10
Hose line with quick-release coupling, 1000 mm	152970	2

\* These components can be mounted in the mounting frame or, by using the adapter set (Order No. 35651), on the profile plate.

### List of additional components for TP600

Description	Order-No.
Extension kit for hydraulic cylinder	120778
Throttle valve	152842
Shut-off valve	152844
Hose line with quick-release coupling, 600 mm	152960
Power pack, hydraulic, 2 l/min	152962
Hose line with quick-release coupling, 1000 mm	152970
Pressure relief device	152971
Cover (for loading weight, 9 kg)	152973
Hose line with quick-release coupling, 1500 mm	158352
Hose line with quick-release coupling, 3000 mm	159386
Power supply unit, attachment fixture, 24V 4.5A, Deutsch	159396
Profile plate, large	159411
Power supply unit, table, 24V 4.5A, Deutsch	162417
Flow rate / rotary speed measuring device	167081
4/3-way solenoid valve with relieving mid-position	167084
4/3-way solenoid valve with recirculating mid-position	167085
Cable set with safety plugs	167091
Coupling nipple	342047
Coupling socket	346491

For further additional components from our "Hydraulics 2000" system, please see our price lists.

#### Learning System for Automation and Communications

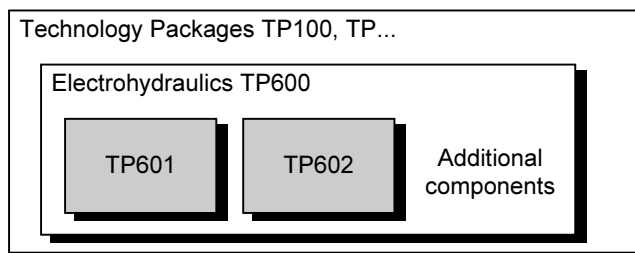

**Component/exercise table (Table 2)**

Description	Exercise												
	1	2	3	4	5	6	7	8	9	10	11	12	13
Relay, 3-fold		1	1	1	1	1	1	1	1	1	1	1	2
Signal input unit, electrical	1	1	1	1	1	1	1	1	1	1	1	1	1
Indicator and distributor unit, electrical		1	1	1	1	1	1	1	1	1	1	1	1
Pressure gauge		2	2	2	2	2	1	2	2	2	1	2	2
One-way flow control valve		2	1				1			1		1	2
Non-return valve, 1 bar									1				
Non-return valve, 5 bar												1	
Pressure relief valve, pressure sequence valve		1	1	1	1	1	1	1	1	2	1	1	1
2-way flow control valve				1	1	1		1	1	1	1		
Non-return valve, piloted							1					1	
4/2-way solenoid valve	1	1	1	1	1	1	1	1	1	1	2	1	1
4/3-way solenoid valve with closed in mid-position							1	1	1	1		1	1
Double-acting cylinder 16/10/200	1	1	1	1	1	1	1	1	1	1	1	1	2
Hydraulic motor, 8 l/min													
Limit switch, electrical, actuated from the left								1	1		1		2
Limit switch, electrical, actuated from the right								1	1	1	1	2	2
Loading weight			1										
Branch tee		2	3	2	2	2	3	2	7	4	4	5	4
Hose line with quick-release coupling, 600 or 1000 mm	4	5	7	7	7	7	9	9	11	11	8	12	12

For exercises 5, 10 and 11 a pressure switch of the equipment set TP 602 is required. For exercise 13 you will need another double-acting cylinder.

## ***Methodological structure of exercises***

All 13 exercises have the same methodological structure.

- The exercises in Part A are structured as follows:
  - Subject
  - Title
  - Training aim(s)
  - Exercise
  - Problem definition
  - Positional sketch

A worksheet then follows for use in carrying out the exercise:

- The suggested solutions in Part C are structured as follows:
  - Circuit diagram, hydraulic-
  - Circuit diagram, electrical
  - Solution description with evaluation and conclusions
  - Practical assembly, hydraulic
  - Practical assembly, electrical
  - Components list, hydraulic
  - Components list, electrical
- How should I work through an exercise?
  - Read the worksheet
  - Complete the worksheet
  - Assemble and commission the control circuit
  - Work out your own solution
  - Compare your solution with the one in this book
  - Incorporate your solution into the control circuit
  - Commission this circuit
  - Does your control circuit fulfil the requirements specified in the-worksheet?



## **Part A – Course**

### **Simple control circuits without limit switches**

Exercise 1:	Sorting device Double-acting cylinder, directly actuated, manually	A-3
Exercise 2:	Component selection on conveyor belt Double-acting cylinder, directly actuated, manually	A-13
Exercise 3:	Lifting station Single-acting cylinder, directly actuated, manually	A-23
Exercise 4:	Bending device Double-acting cylinder, latching	A-29
Exercise 5:	Press-fitting device Double-acting cylinder, latching, return stroke using pressure switch	A-33
Exercise 6:	Stamping machine Double-acting cylinder, differential circuit	A-39
Exercise 7:	Door control Double-acting cylinder, interlock, INCHING operation	A-43

## ***Control circuits with limit switches***

Exercise 8:	Machining unit Differential circuit, return stroke using limit switch	A-49
Exercise 9:	Feed for drilling machine Rapid-traverse feed circuit, speeds controlled by limit switch	A-53
Exercise 10:	Press Pressure control circuit with limit switch and pressure switch	A-59
Exercise 11:	Feed device Pressureless pump bypass with limit switch	A-63

## ***Control circuits with two actuators***

Exercise 12:	Assembly device Pressure-dependent sequence control with cylinder and hydraulic motor	A-69
Exercise 13:	Lifting device for packages Position-dependent sequence control with two cylinders	A-75

We hope you enjoy the designing and practical assembly of the circuits.  
Understanding hydraulics is fun!



## *Electrohydraulics*

### **Sorting device**

- Understanding an directly actuated, manually operated circuit
  - Actuation of a double-acting cylinder using a 4/2-way solenoid valve
  - Naming the most important components of a double-acting cylinder
  - Naming the most important components of a 4/2-way solenoid valve
  - Understanding the use of the electrical signal input unit
  - Selection of required components
  - Developing and drawing the hydraulic and electrical circuit diagrams
  - Understanding the variants available for mounting components on the profile plate
  - Mounting components in a mounting frame
  - Working with hydraulic hose lines
  - Connecting up electrical test leads in accordance with a diagram
  - Commissioning the control circuit
- 
- Complete the worksheets
  - Define the required components
  - Draw the hydraulic and electrical circuit diagrams
  - Label the connections
  - Number the components in the circuit assembly
  - Familiarise yourself with the hydraulic and electrical power supplies
  - Carry out practical assembly of the hydraulic and electrical control circuits
  - Commission the control circuit
  - Compile the components lists
  - Dismantle the control circuit and replace the components in the storage tray

*Subject*

*Title*

*Training aims*

*Problem definition*

# A-4

## Exercise 1

*Exercise* A sorting device is used to sort heavy steel workpieces.

When a START pushbutton is pressed, the piston rod of a double-acting cylinder pushes the adjacent workpiece off the conveyor belt. When the START pushbutton is released, the piston rod returns to its retracted end position.

Parameter

Only a small number of hydraulic and electrical components should be used.

*Fig. 1/1:  
Positional sketch*

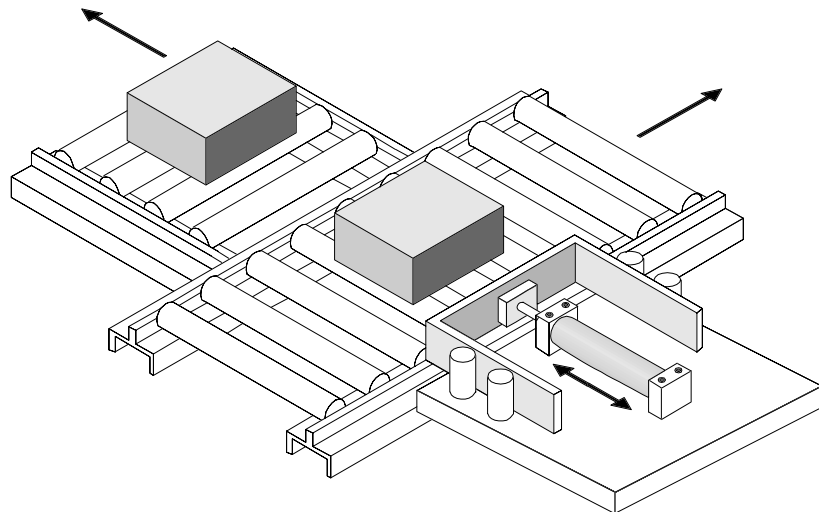

## WORKSHEET

Produce a freehand sketch of the double-acting cylinder.

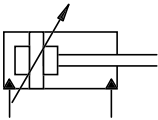
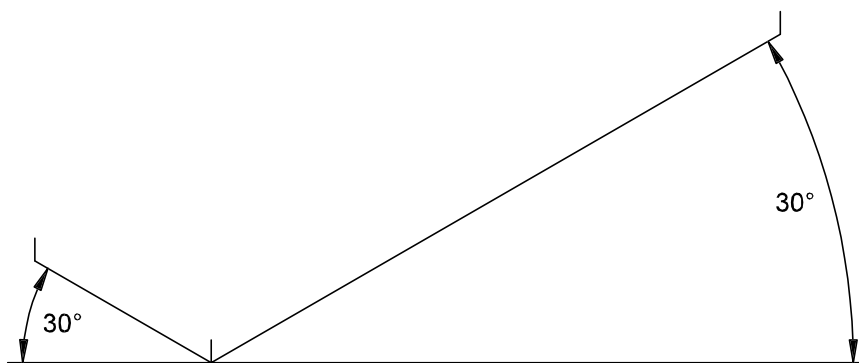

Fig. 1/2:  
Isometric projection of  
cylinder, 16/10/200



Name the six most important components of the cylinder.  
Number these on your freehand sketch.

1. \_\_\_\_\_
2. \_\_\_\_\_
3. \_\_\_\_\_
4. \_\_\_\_\_
5. \_\_\_\_\_
6. \_\_\_\_\_

# A-6

## Exercise 1

Produce a freehand sketch of the 4/2-way solenoid valve.

Fig. 1/3:  
Isometrische Projektion  
4/2-Wege-Magnetventil

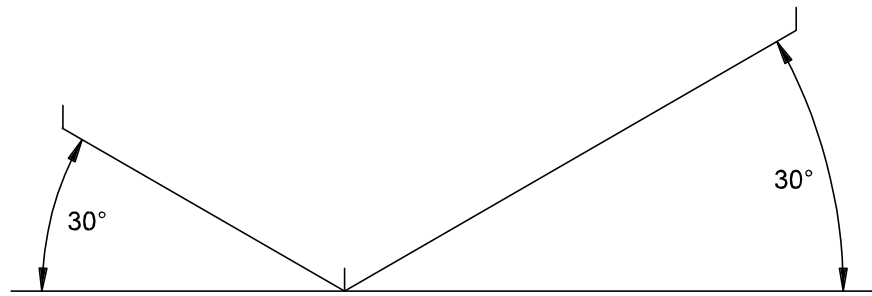
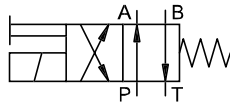

Name five major components of the 4/2-way solenoid valve.  
Number these on your freehand sketch.

1. \_\_\_\_\_
2. \_\_\_\_\_
3. \_\_\_\_\_
4. \_\_\_\_\_
5. \_\_\_\_\_

## WORKSHEET

Name five major components of the electrical signal input unit.  
Number these on the illustration.



Fig. 1/4:  
Signal input unit (photo)

1. \_\_\_\_\_
2. \_\_\_\_\_
3. \_\_\_\_\_
4. \_\_\_\_\_
5. \_\_\_\_\_

# A-8

## Exercise 1

Fig. 1/5:  
Signal input unit;  
front panel

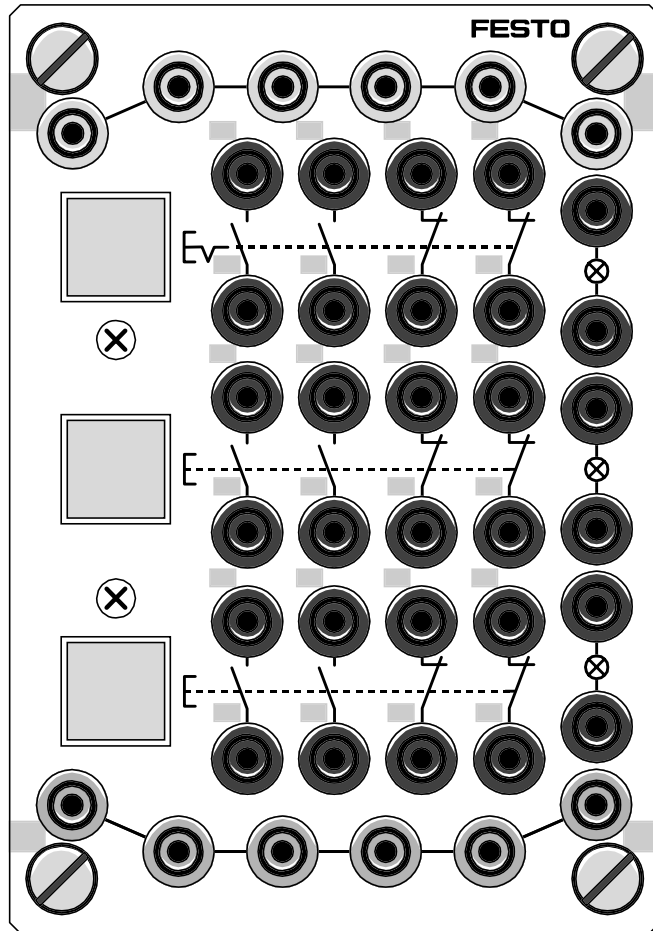

Mark the connection designations on the front panel.

What colour are the 4 mm sockets? Please indicate this.

What is the difference in the function of a pushbutton and a switch?

---

---

---

---

## WORKSHEET

Complete the hydraulic circuit diagram.

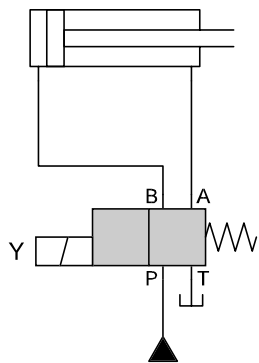

Fig. 1/6:  
Circuit diagram, hydraulic

Complete the list of hydraulic components.

Qty.	Description
	Hydraulic power pack, 2 l/min
	Double-acting cylinder, 16/10/200
	Hose line with quick-release coupling, 600 and 1000

List of  
hydraulic components

# A-10

## Exercise 1

Complete the electrical circuit diagram.

Fig. 1/7:  
Circuit diagram, electrical

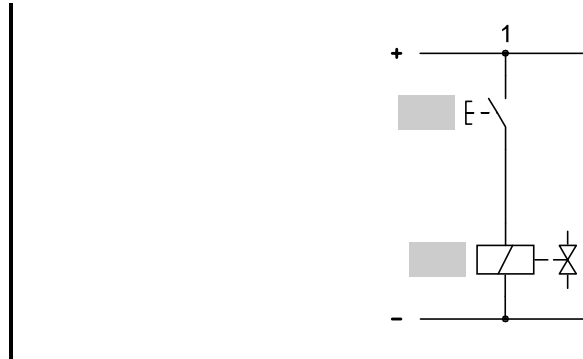

Complete the list of electrical components.

List of  
electrical components

Qty.	Description
	Signal input unit, electrical
	Cable set, universal with safety plugs
	Power supply unit, 24V



## WORKSHEET

How do you mount the cylinder on the profile plate?

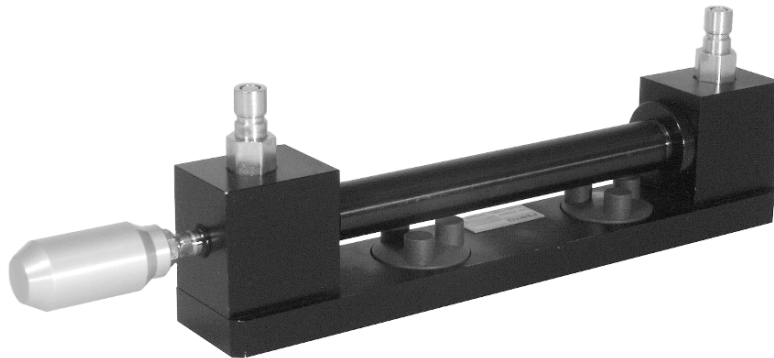

Fig. 1/8:  
Variant B

How do you mount the 4/2-way solenoid valve on the profile plate?

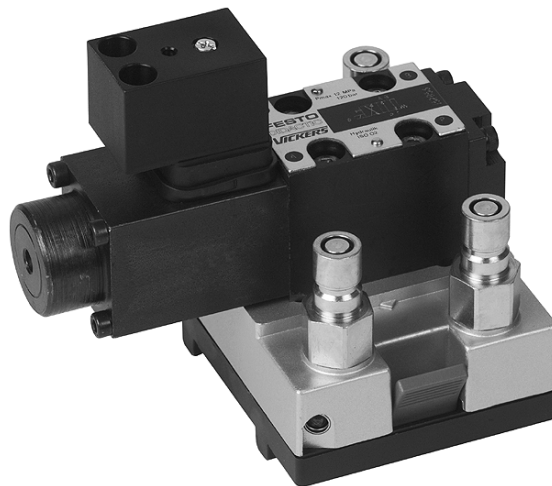

Fig. 1/9:  
Variant A

# A-12

## Exercise 1

How do you mount the electrical signal input unit on the profile plate??

Fig. 1/10:  
Variant D

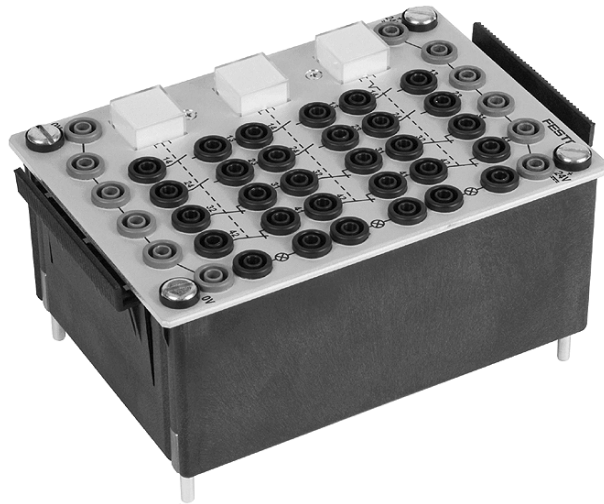

---

---

---

Where else could you mount the electrical signal input unit?

---

---

---