

**FESTO**

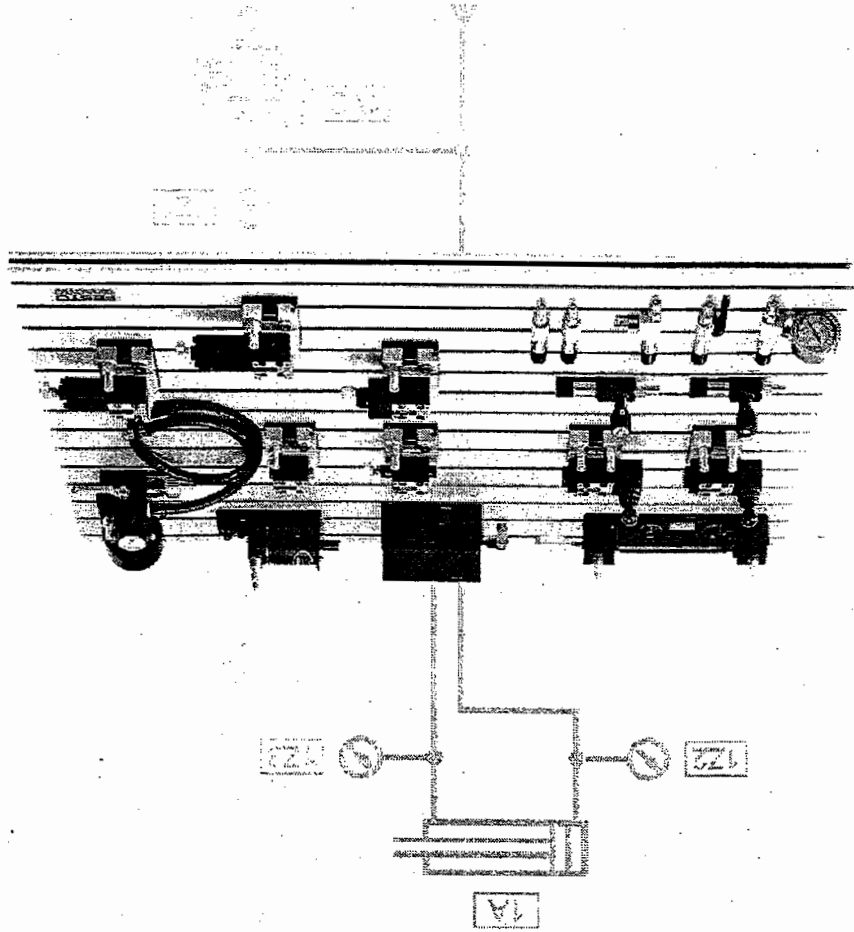

Workbook Basic Level

# Hydraulics

© Festo Didactic GmbH & Co. KG, 73770 Denkendorf, Germany, 2003  
The copying, distribution and utilization of this document as well as the communication of its contents to others without expressed authorization is prohibited. Offenders will be held liable for the payment of damages. All rights reserved, in particular the right to carry out patent, utility model or ornamental design registrations.  
Parts of this training documentation may be duplicated, solely for training purposes, by persons authorised in this sense.

Order no.: 094468  
Description: TEACHW. HYDRAUL.  
Designation: D.S501-C-SIBU-GB  
Edition: 07/2003  
Layout: 14.07.2003, OCKER Ingenieurbüro  
Graphics: OCKER Ingenieurbüro  
Author: D. Waller, H. Werner

Authorised applications and liability  
The Learning System for Automation and Communication has been developed and prepared exclusively for training in the field of automation and communication. The training organization and / or trainee shall ensure that the safety precautions described in the accompanying Technical documentation are fully observed.  
Festo Didactic hereby excludes any liability for injury to trainees, to the training organization and / or to third parties occurring as a result of the use or application of the station outside of a pure training situation, unless caused by premeditation or gross negligence on the part of Festo Didactic.

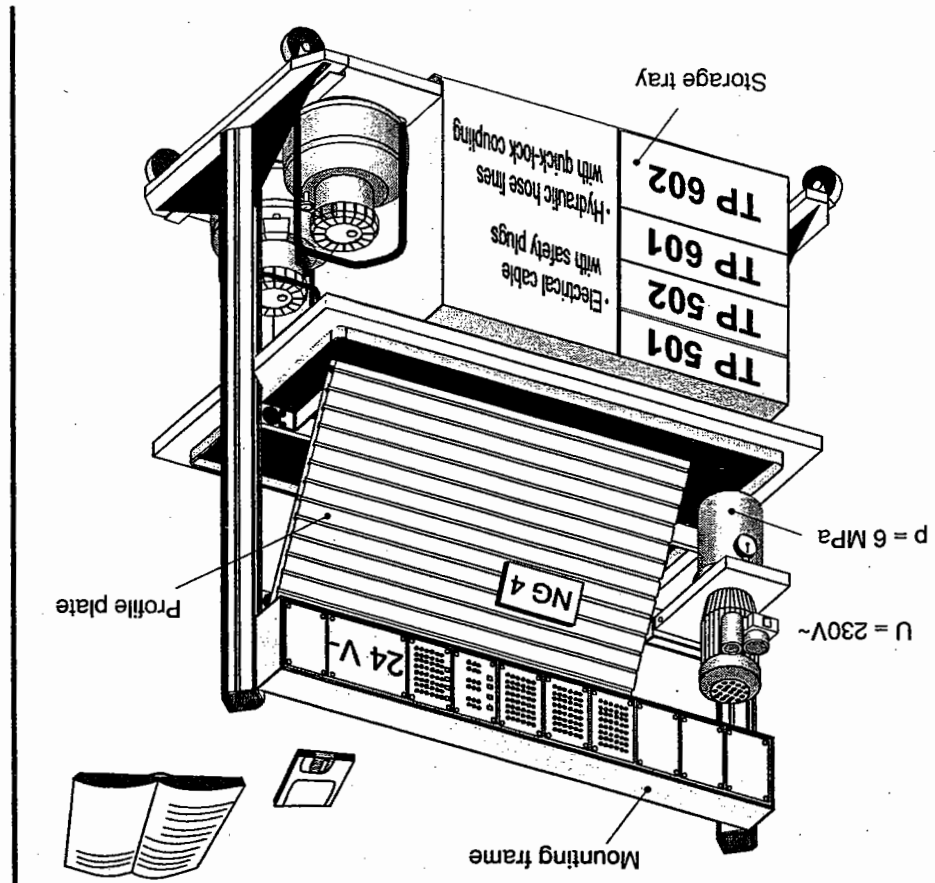

Fig. 1:  
Hydraulics 2000 –  
i.e. mobile workstation

Festo Didactic's Learning System for Automation and Communications is designed to meet a number of different training and vocational requirements. The Festo Training Packages are structured accordingly:

- Basic Packages provide fundamental knowledge on a wide range of technologies.
- Technology Packages deal with important areas of open-loop and closed-loop control technology.
- Function Packages explain the basic functions of automation systems.
- Application Packages provide basic and further training closely oriented to everyday industrial practice.

Technology Packages deal with the technologies of pneumatics, electropneumatics, programmable logic controllers, automation with PCs, hydraulics, electrohydraulics, proportional hydraulics and application technology (handling).

## Preface

The modular structure of the Learning System permits applications to be assembled which go beyond the scope of the individual packages. It is possible, for example, to use PLCs to control pneumatic, hydraulic and electrical actuators.

All training packages have an identical structure:

- Hardware
- Courseware
- Software
- Courses

The hardware consists of industrial components and installations, adapted for didactic purposes.

The courseware is matched methodologically and didactically to the training hardware. The courseware comprises:

- Textbooks (with exercises and examples)
- Workbooks (with practical exercises, explanatory notes, solutions and data sheets)
- OHP transparencies and videos (to bring teaching to life)

Teaching and learning media are available in several languages. They have been designed for use in classroom teaching but can also be used for self-study purposes.

In the software field, computer-based training programs and programming software for programmable logic controllers are available.

Festo Didactic's range of products for basic and further training is completed by a comprehensive selection of courses matched to the contents of the technology packages.

Part A Course	Exercises
Part B Fundamentals	Reference to the text book
Part C Solutions	Function diagrams, circuits, descriptions of solutions and equipment lists
Part D Appendix	Storage tray, mounting technology and datasheets

**Content**

**Aim – Professional competence**

- Training of team skills, willingness to co-operate, willingness to learn, independence and organisational skills.
- Fostering of key qualifications:
  - Technical competence, personal competence and social competence
  - form professional competence.
- Exercises with exercise sheets and solutions, leading questions.
- Industrial components on the profile plate.

New in Hydraulic 2000:

Latest information about the technology package TP501.



A-41	Exercise 10: Painting booth Flow control valve characteristic
A-37	Exercise 9: Rotary machining station Flow control valve and counter-holding
A-33	Exercise 8: Cold-store door Accumulator
A-29	Exercise 7: Conveyor tensioning device 4/3-way valve with bypass to pump
A-23	Exercise 6: Furnace door control Double-acting cylinder
A-19	Exercise 5: Hardening furnace Single-acting cylinder (measurement and calculation)
A-15	Exercise 4: Calendar feeding device Single-acting cylinder (basic circuit)
A-11	Exercise 3: Drawing press Hydraulic resistances
A-7	Exercise 2: Package lifting device Pressure relief valve characteristic
A-3	Exercise 1: Automatic lathe Pump characteristic

**Section A – Course**

11	Introduction
13	Notes on safety
13	Notes on operation
14	Technical notes
17	Training contents
19	Equipment set for "Hydraulics Basic Level"
24	Component / exercise table for TP 501

**Table of contents**

## Section B - Fundamentals

- Exercise 11: Embossing machine  
A-45
- Exercise 12: Surface grinding machine  
A-49
- Exercise 13: Drilling machine  
A-55
- Exercise 14: Bulkhead door  
Hydraulic clamping of a cylinder  
A-59
- Exercise 15: Ferry loading ramp  
Flow control valve in inlet and outlet lines  
A-63
- Exercise 16: Skip handling  
Varying load  
A-69
- Exercise 17: Bonding press  
Comparison of pressure regulator and –  
pressure relief valve  
A-73
- Exercise 18: Assembly device  
Pressure sequence circuit,  
displacement-step diagram  
A-77
- Exercise 19: Assembly device  
Calculation of pressure and time  
A-81
- Exercise 20: Tipping container  
Electrohydraulics  
A-85



**Section D – Appendix**

D-3	Storage tray
D-4	Mounting systems
D-6	Sub-base
D-7	Coupling system
...	Data sheets

**Section C – Solutions**

C-3	Solution 1: Automatic lathe
C-7	Solution 2: Package lifting device
C-11	Solution 3: Drawing press
C-15	Solution 4: Calender feeding device
C-19	Solution 5: Hardening furnace
C-23	Solution 6: Furnace door control
C-27	Solution 7: Conveyor tensioning device
C-33	Solution 8: Cold-store door
C-37	Solution 9: Rotary machining station
C-41	Solution 10: Painting booth
C-45	Solution 11: Embossing machine
C-49	Solution 12: Surface grinding machine
C-59	Solution 13: Drilling machine
C-65	Solution 14: Bulkhead door
C-69	Solution 15: Ferry loading ramp
C-73	Solution 16: Skip handling
C-77	Solution 17: Bonding press
C-79	Solution 18: Assembly device
C-83	Solution 19: Calculation for an assembly device
C-85	Solution 20: Tipping container



## Introduction

This workbook forms part of Festo Didactic's Learning System for Automation and Communications. The Technology Package "Hydraulics", TP500, is designed to provide an introduction to the fundamentals of hydraulic control technology. This package comprises a basic level and an advanced level. The basic level package TP501 teaches basic knowledge of hydraulic control technology, while the advanced level package TP502 builds on this.

The basic level hydraulic exercises are designed to be carried out with manual actuation. It is, however, also possible to use electrical actuation. The hydraulic components have been designed to provide the following:

- Easy handling
- Secure mounting
- Environmentally-friendly coupling system
- Compact component dimensions
- Authentic measuring methods

We recommend the following for the practical execution of the exercises:

- Hydraulic components: Equipment set TP501
- One hydraulic power pack
- A number of hose lines
- A profile plate or a suitable laboratory trolley
- A measuring set with the appropriate sensors

This workbook provides knowledge of the physical interrelationships and the most important basic circuits in hydraulics. The exercises deal with the following:

- Plotting of characteristics for individual components
- Comparison of the use of different components
- Assembly of various basic circuits
- Use of basic hydraulics equations

The following technical equipment is required for safe operation of the components:

- A hydraulic power pack providing an operating pressure of 60 bar and a flow rate of 2 l/min
- An electrical power supply of 230V AC for the hydraulic power pack
- A power supply unit with an output of 24V DC for solenoid-actuated valves
- A Festo Didactic profile plate for mounting the components

The theoretical background is described in the "Hydraulics Basic Level" textbook TP501. Technical descriptions of the components used are given in the data sheets in Part D of this workbook.

Festo Didactic offers the following further training material for hydraulics:

- Magnetic symbols
- Hydraulics slide rule
- Set of OHP transparencies
- Transparent models
- Interactive video
- Symbol library

6. Switch off the hydraulic power pack first and then the electrical power supply.

**Couplings must be connected and disconnected only under zero pressure!**

5. Before dismantling the circuit, ensure that pressure in hydraulic components has been released.
4. Switch on the electrical power supply first and then the hydraulic power pack.
3. Check that all return lines are connected and all hose lines are securely fitted.
2. All components must be securely fitted to the profile plate, i.e. securely snap-fitted or bolted down.
1. The hydraulic power pack and electrical power supply must be switched off during the assembly of the circuit.

Always work in the following sequence when assembling a hydraulic circuit.



### **Notes on operation**

- Exercise care when switching on the hydraulic power pack. Cylinders may advance unexpectedly!
- Do not exceed the maximum permissible operating pressure (see data sheets).
- Observe all general safety instructions (DIN 58126 and VDE 100).



### **Notes on safety**

Observe the following in the interests of your own safety:

**Technical notes**

Observe the following in order to ensure safe operation.

- The hydraulic power pack PN 152962 incorporates an adjustable pressure relief valve. In the interests of safety, the pressure is limited to approx. 60 bar (6 MPa).
- The maximum permissible pressure for all hydraulic components is 120 bar (12 MPa).

**The operating pressure should not exceed 60 bar (6 MPa).**

- In the case of double-acting cylinders, the pressure intensification effect may produce an increased pressure proportional to the area ratio of the cylinder. With an area ratio of 1:1.7 and an operating pressure of 60 bar (6 MPa), this increased pressure may be over 100 bar (10 MPa)!

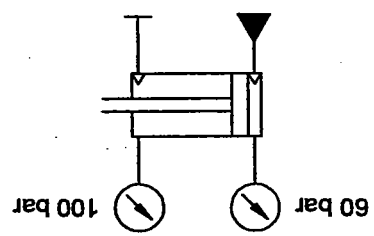

Fig. 2: Pressure intensification

- If connections are detached under pressure, the non-return valve in the coupling may cause pressure to become trapped in the valve or other component concerned. The pressure relieving device PN 152971 can be used to release this pressure. Exception: This is not possible in the case of hose lines and non-return valves.
- All valves, other components and hose lines are fitted with self-closing quick-release couplings. This prevents the accidental spillage of hydraulic fluid. In the interests of simplicity, these couplings are not shown in circuit diagrams.

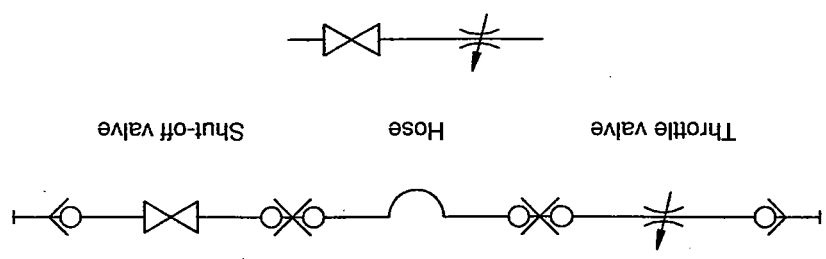

Fig. 3: Simplified drawing of self-closing couplings

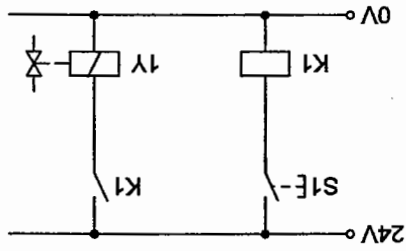
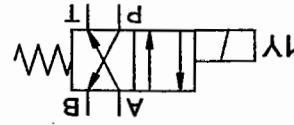
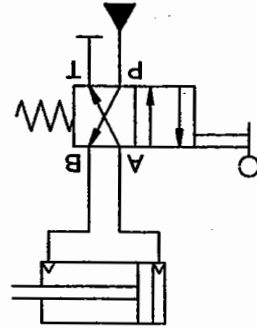
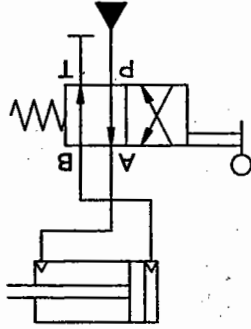

Fig. 7:  
Solenoid-actuated  
directional control valve



Circuit diagram



Practical assembly

Fig. 6:  
Directional control valves  
with various  
normal positions

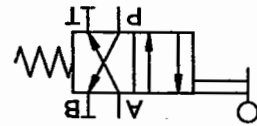

4/2-way valve

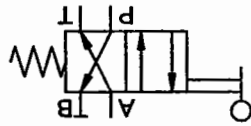

4/2-way valve

Fig. 5:  
Practical assembly

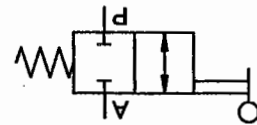

2/2-way valve

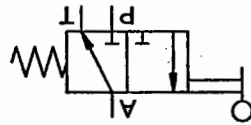

3/2-way valve

Fig. 4:  
Circuit diagram

- It is frequently necessary when assembling a control circuit to modify the given circuit diagram. Within the scope of the equipment set in this Training Package, the following alternative solutions are possible:
  - Plugs can be used to change the function of directional control valves (Figs. 4 and 5).
  - Directional control valves with different normal positions can be used (Fig. 6).
  - Solenoid-actuated valves can be used in place of hand lever valves (Fig. 7).

**Flow rate sensor**

The flow rate sensor consists of:

- A hydraulic motor, which converts the flow rate  $q$  into a rotary speed  $n$ .
- A tachogenerator, which produces a voltage  $V$  proportional to the rotary speed  $n$ .
- A universal display unit, which converts the flow rate  $q$  into  $l/min$ . The universal display should be set to sensor no. 3 for this purpose.

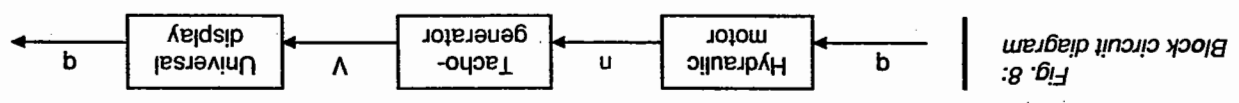

Fig. 9: Circuit diagrams, hydraulic and electrical

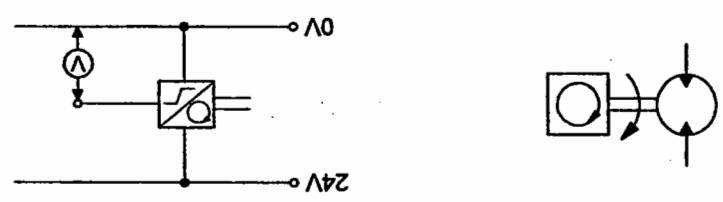
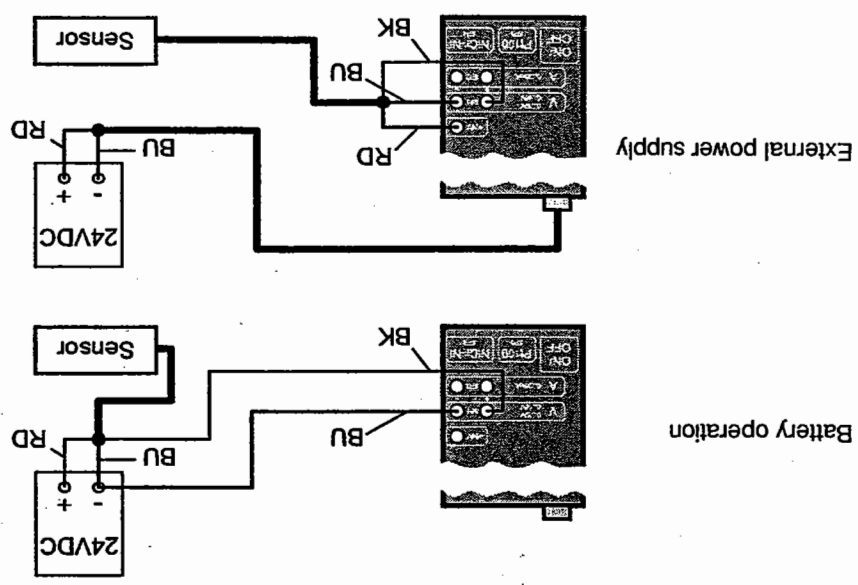

Fig. 10: Connecting up the universal display





## **Training contents**

- Characteristics of valves and other components.
- Uses of individual valves and other components.
- Comparison of uses and functions of different valves and other components.
- Measurement of variables such as pressure, flow rate and time.
- Control of pressure and speed.
- Calculations of area ratios, forces, power and speed.
- Basic physical principles of hydraulics.
- Use of basic hydraulics equations.
- Understanding and drafting of circuit diagrams.
- Drafting of displacement/step diagrams.
- Use of symbols in accordance with DIN/ISO 1219.
- Assembly and commissioning of control circuits, including fault-finding.
- Assessment of energy consumption.
- Basic hydraulic circuits such as a pressure sequence circuit, a bypass circuit to the pump, a differential circuit, circuits with flow control valves in the inlet, outlet and bypass, circuits with counter-holding and bypass circuits with a non-return valve.

## List of training aims

Exercise	Training aims
1	Drawing a pump characteristic.
2	Drawing a characteristic for a pressure relief valve.
3	Measuring flow resistances.
4	Application of a non-return valve. Use of a 2/2-way valve to control a single-acting cylinder.
5	Application of a 3/2-way valve. Determination of times
6	Application of a 4/2-way valve. Determination of times
7	Application of a 4/3-way valve. Use of a pilot-operated non-return valve.
8	Use of a hydraulic accumulator as a power source. Use of accumulator to power advance and return strokes of cylinder after pump is switched off.
9	Application of a 2-way flow control valve. Assembly of a counter-pressure circuit.
10	Plotting of characteristic for a 2-way flow control valve. Comparison between this valve and a throttle valve.
11	Application of a one-way flow control valve. Difference between flow control valve and throttle valve on the basis of a concrete application.
12	Design and mode of operation of a differential circuit. Influence of piston areas on pressures
13	Design of a control circuit with reduced output pressure. Explanation of mode of operation of a 3-way pressure regulator.
14	Hydraulic clamping with a double-acting cylinder. Comparison of circuits with and without counter-holding.
15	Speed control circuit with tractive load. Comparison of circuits with flow control valves in the inlet line and outlet line respectively.
16	Circuit for a double-acting cylinder with a varying load.
17	Specification of pressure for a double-acting cylinder. Choice of either a pressure relief valve or a pressure regulator
18	Pressure sequence circuit. Drawing of a displacement/step diagram
19	Calculation of forces associated with a double-acting cylinder Calculation of advance-stroke time of a cylinder piston.
20	Electrohydraulic control circuit.

**Equipment set for "Hydraulics Basic Level"**

TP501, PN 080246

Description	Order No.	Qty.
Pressure gauge	152841	3
Throttle valve	152842	1
One-way flow control valve	152843	1
Shut-off valve	152844	1
Non-return valve, opening pressure 1 bar	152845	1
Non-return valve, opening pressure 5 bar	152846	1
Branch tee	152847	7
Pressure relief valve	152848	1
Pressure relief valve, piloted	152849	1
Pressure regulator	152850	1
Flow control valve	152851	1
Non-return valve, hydraulically piloted	152852	1
Double-acting cylinder	152857	1
Hydraulic motor	152858	1
Diaphragm accumulator	152859	1
Loading weight, 9 kg	152972	1
4/2-way hand lever valve	152974	1
4/3-way hand lever valve, recirculation mid-position	152977	1









152845, 152846

*Additional equipment*

<i>Description</i>	<i>Order No.</i>	<i>Qty.</i>
Stop-watch	151504	1
4/3-way hand lever valve, closed in mid-position	152975	1
4/3-way hand lever valve, relieving mid-position	152976	1
Relay, 3-fold	162241	1
Signal input unit, electrical	162242	1
Flow-rate sensor	183736	1
4/2-way solenoid valve	167082	1
4/3-way solenoid valve, closed in mid-position	167083	1
4/3-way solenoid valve, relieving mid-position	167084	1
4/3-way solenoid valve, recirculating mid-position	167085	1
Universal display	183737	1
Pressure sensor	184133	1

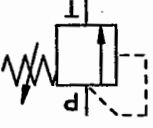
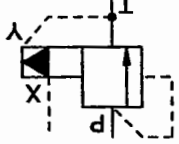
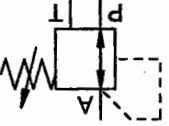

*Accessories*

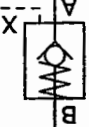
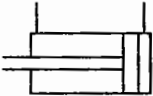
<i>Description</i>	<i>Order No.</i>	<i>Qty.</i>
Profile plate, large	159411	1
Schlauchleitung, 600 mm	152960	12
Hydraulik-Aggregat	152962	1
Hose line, 1000 mm	152970	4
Pressure relieving device	152971	1
Protective cover (for weight, 9kg)	152973	1
Power supply unit, 24 V, 4.5 A	162417	1
Cable set with safety plugs	167091	1

Symbol	Description
	Pressure gauge
	Throttle valve
	One-way flow control valve
	Shut-off valve
	Non-return valve
	Branch tee
	Pressure relief valve
	Pilot-operated pressure relief valve
	Pressure regulator
	Flow control valve
	Pilot non-return valve
	Double-acting cylinder

Symbols for equipment set TP501

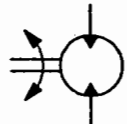
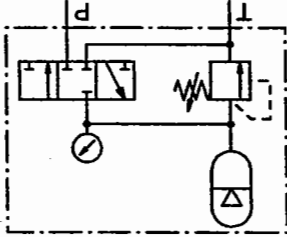
Symbols for equipment set TP501

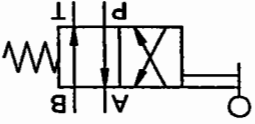
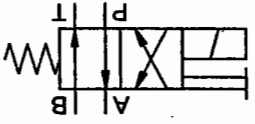
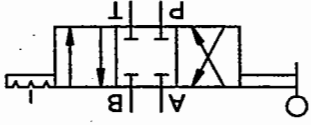
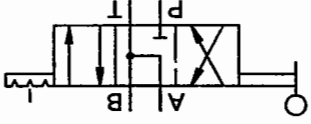
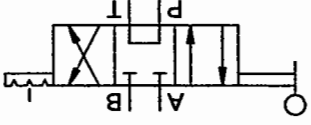
Description	Symbol
Hydraulic motor	
Diaphragm accumulator, detailed	
Diaphragm accumulator, simplified	
Weight	
4/2-way hand lever valve	
4/2-way solenoid valve	
4/3-way hand lever valve, closed in mid-position	
4/3-way hand lever valve, relieving mid-position	
4/3-Wege-Handhebelventil mit Umlaufstellung	

Description	Symbol
4/3-way solenoid valve, closed in mid-position	
4/3-way solenoid valve, relieving mid position	
4/3-way solenoid valve, recirculating mid-position	
Hose line	
Hydraulic-power pack, detailed	
Hydraulic power pack, simplified	
Pressure sensor	
Flow rate sensor	
Hydraulic motor with tachogenerator	

Symbols for equipment set TP501

**Component / exercise table for TP 501**

Exercises	Description	1	2	3	4	5	6	7	8	9	10	11	12	13	14	15	16	17	18	19	20
	Pressure gauge	1	1	3	1	3	1	3	1	1	2	5	3	5	3	4	3	3	3	3	2
	Throttle valve											1									
	One-way flow control valve																				
	Shut-off valve	1	1	1	1	1	1	1	1	1	1	1	1	1	1	1	1	1	1	1	1
	Non-return valve, 1 bar																				
	Non-return valve, 5 bar																				
	Branch tee	2	3	4	3	2	3	3	3	6	2	4	4	5	4	4	4	4	5	7	2
	Pressure relief valve *)	1	2	1	1	1	1	1	1	2	2	2	2	1	1	2	2	3	2	3	1
	Pressure relief valve, piloted			(1)	(1)					(1)	(1)	(1)			(1)	(1)	(1)	(1)	(1)		
	Pressure regulator																				
	Flow control valve																				
	Piloted non-return valve																				
	Cylinder, double-acting																				
	Hydraulic motor																				
	Diaphragm accumulator																				
	Weight																				
	4/2-way hand lever valve																				
	4/3-way hand lever valve recirculating mid-position																				
	Hydraulic power pack	1	1	1	1	1	1	1	1	1	1	1	1	1	1	1	1	1	1	1	1
	Hose line, 600 mm	3	5	5	6	5	4	7	5	9	4	12	5	12	10	11	8	5	12	4	
	Hose line, 1000 mm																				
	Stop-watch																				
	Pressure sensor			(2)																	
	Flow-rate sensor	1	1	1	1	1	1	1	1	1	1	1	1	1	1	1	1	1	1	1	1
	Universal display	1	1	1	1	1	1	1	1	1	1	1	1	1	1	1	1	1	1	1	1
	Power supply unit	1	1	1	1	1	1	1	1	1	1	1	1	1	1	1	1	1	1	1	1

\*) If a sufficient number of directly-controlled pressure relief valves is not available, the pilot-operated pressure relief valve can also be used.



- Hydraulic circuit diagram
- Practical assembly
- Component list
- Solution description
- Evaluation
- Conclusions

The solutions in Section C contain the following:

A worksheet then follows for use in carrying out the exercise.

- Subject
- Title
- Training aim(s)
- Problem definition
- Exercise
- Positional sketch

The exercises in Section A are structured as follows:

The exercises appear in Section A of the workbook, with solutions to these in Section C. The methodological structure is the same for all exercises. *Methodological structure of exercises*

Description	Order No.	Qty.
4/3-way solenoid valve, relieving mid-position	167084	1
Signal input unit, electrical	162242	1
Relay, 3-fold	162241	1
Cable set	167091	1

**Electrical equipment for exercise 20**



**Section D – Appendix**

D-3	Storage tray	152 841
D-4	Mounting systems	152 842
D-6	Sub-base	152 843
D-7	Coupling system	152 844
		152 845, 152 846
	Non-return valve	152 847
	Branch tee	152 848
	Pressure relief valve	152 849
	Piloted pressure relief valve	152 850
	Pressure reducing valve	152 851
	Flow control valve	152 852
	Cylinder	152 857
	Hydraulic motor	152 858
	Diaphragm accumulator	152 859
	Hose line, 600 mm, 1000 mm	152 960, 152 970
	Hydraulic power pack	152 962
	Loading weight, 9 kg	152 972
	4/2-way hand-lever valve	152 974
	4/3-way hand-lever valve with closed in mid-position	152 975
	4/3-way hand-lever valve with relieving mid-position	152 976
	4/3-way hand-lever valve with recirculating mid-position	152 977

**Data sheets**

**Data sheets**

- 162 241 Relay, 3-fold
- 162 242 Signal input, electrical
- 167 082 4/2-way solenoid valve
- 167 083 4/3-way solenoid valve with closed in mid-position
- 167 084 4/3-way solenoid valve with relieving mid-position
- 167 085 4/3-way solenoid valve with recirculating mid-position

All the components of the equipment set for the technology package TP 501 are retained in a storage tray.  
This storage tray serves both as packaging for despatch purposes and as a drawer insert for the Didactic furniture range.

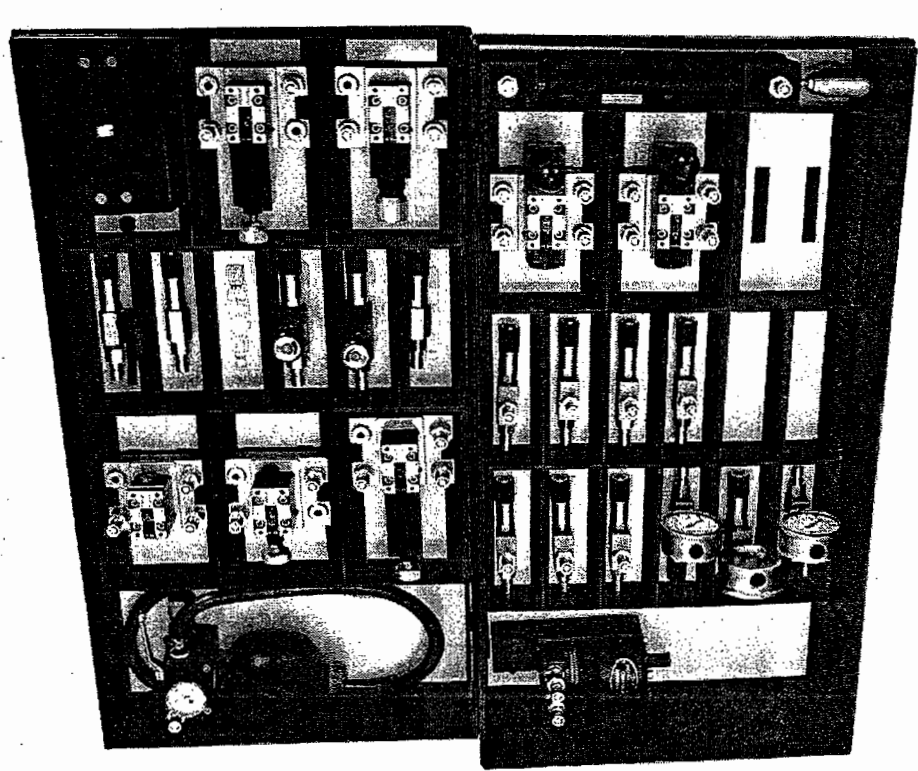

Equipment set TP 501  
in storage tray

### Storage tray

## Mounting systems

The components of the equipment set are mounted on the Festo Didactic profile plate. The profile plate has 14 parallel T-grooves equally spaced 50 mm apart.

There is a choice of four alternative systems for mounting the components on the profile plate:

**Variant A:** Detent system, used without additional devices. Clamping mechanism with lever and spring which can be moved along the T-groove, for light non-load-bearing components

**Variant B:** Rotary system, used without additional devices. Grip nut with locking disc and T-head bolt, vertical or horizontal alignment, for medium-weight load-bearing components

**Variant C:** Screw-in system, used with additional devices. Cheese-head bolt with T-head nut, vertical and horizontal alignment, for heavy load-bearing components or components which are rarely removed from the profile plate

**Variant D:** Plug-in system, used with adapter. Components used on plug-in assembly board with locating pins, can be moved along the T-groove, for light non-load-bearing components

The signal input unit and indicator and relay plates can also be mounted in the mounting frame for ER units.

In the case of **variant D**, our well-proven ER units, for plug-in assembly boards with locating pins on a 50 mm grid pattern, can be attached to the profile plate by means of adapters. A black plastic adapter is required for each locating pin. The adapters are positioned in the T-grooves at intervals of 50 mm and secured by rotating them through 90°. The locating pins of the ER units are then inserted into the holes in the adapters.

**Variant C** is used with heavy components or components which are to be secured to the profile plate once only or seldom removed. In this case, components are secured by means of internal-hex-head bolts and T-head nuts.

After the locking disc has been set to the desired position, the component is placed on the profile plate. When the grip nut is turned clockwise, the T-head bolt is turned through 90° in the T-groove by thread friction. The grip nut is then turned further to clamp the component to the profile plate.

In the case of **variant B**, the component is secured to the profile plate by a T-head bolt and a blue grip nut. A locking disc which can be positioned in steps of 90° is used to position the components, allowing these to be aligned either parallel to or at right angles to the grooves.

In the case of **variant A**, a slide engages in the T-groove of the profile plate. This slide is pre-tensioned by a spring. When the blue lever is pressed, the slide is retracted to allow the component to be removed from or fitted to the profile plate. Components are aligned with the groove and can be moved along this.

**Sub-base**

The hole pattern of the sub-base for valves of nominal size 4 (DN 4) conforms to ISO 228 size 02. Due to the similarity between this hole pattern and the one for size 03, it has been possible by changing the dimensions slightly and providing additional mounting holes to allow valves of nominal size 6 (DN 6) to be used as well.

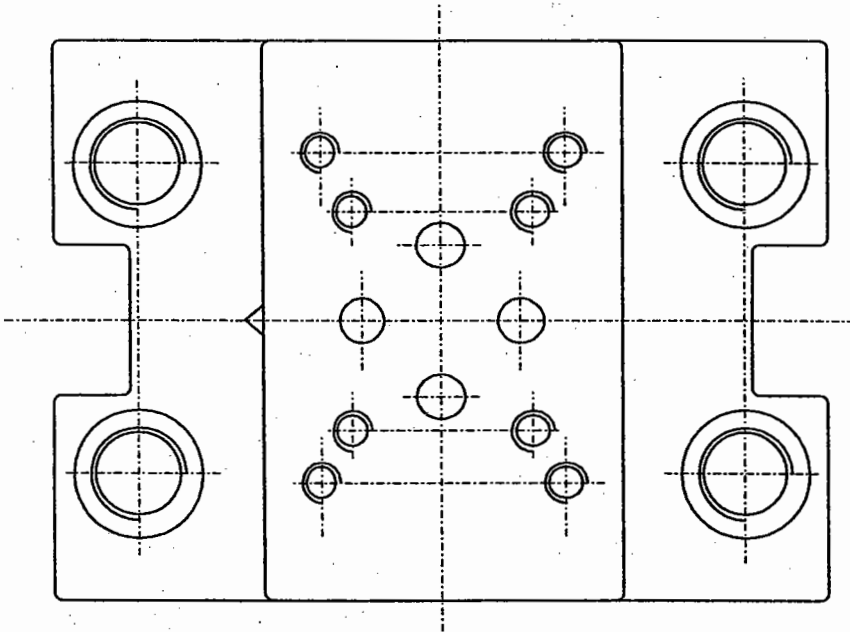

Connection panel



Self-closing coupling

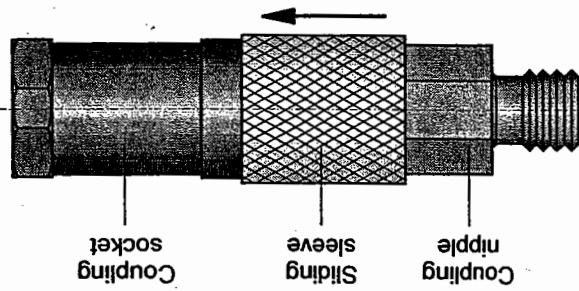

All hydraulic components are equipped with self-closing couplings. These have been designed in particular enabling circuits to be assembled and dismantled with nearly no oil leakage, while at the same time allowing connections to be made with very little effort.

A coupling consists of a nipple and socket. Connections are made by pushing a socket onto a nipple. The sliding sleeve then engages to provide a secure connection. This sleeve is pushed back to detach a connection. A spring then pushes the socket away from the nipple.

Coupling nipples can be screwed into the sub-bases. All valves mounted on sub-bases can thus be connected up via nipples. All other components should preferably also be equipped with nipples, and hoses and hoses should therefore be fitted with two sockets. Components such as shut-off valves or non-return valves which are connected on one side to hoses and on the other to components are equipped with coupling nipples and coupling sockets respectively.

## Coupling system

Since the couplings close to create a leakproof seal, it may occur that pressure is trapped inside a component. If this happens, the force required to operate the coupling will increase to such an extent that the component cannot subsequently be coupled up again. The remedy in cases of this kind is to use a pressure relieving device. This is of similar design to a coupling socket but incorporates an adjustment spindle. The spindle should initially be rotated fully out and the device then pushed onto a nipple until the sliding sleeve engages. The spindle can be rotated inward to push back the sealing pin of the nipple and open the seal. The pressure behind the nipple will then be relieved; a drop of oil may escape during this operation. The pressure relieving device can be removed again by pushing back the sliding sleeve.

<b>Hydraulic</b>	
Medium	Mineral oil, recommended viscosity 22 cSt (mm <sup>2</sup> /s)
Accuracy	1,6 % of full-scale value
Indicating range	10 MPa (100 bar)
Operating pressure	Static: 3/4 of full-scale value Dynamic: 2/3 of full-scale value
Damping fluid	Glycerine
Actuation	Hydraulic via a spiral Bourdon tube
Connections	For coupling nipple/socket

Technical data

Note

The pressure gauge has a glycerine filled to protect it against impacts, condensation and the entry of water during cleaning.

Function

The branch tee can be interposed at any desired point or connected close to a measuring point to allow pressure measurement. The pressure causes a spiral Bourdon tube to open out. This motion is applied to the pointer of the pressure gauge. The position of the pointer is therefore proportional to the pressure applied.

Design

Pressure gauge, branch tee, 2 connections (A = nipple, B = socket)

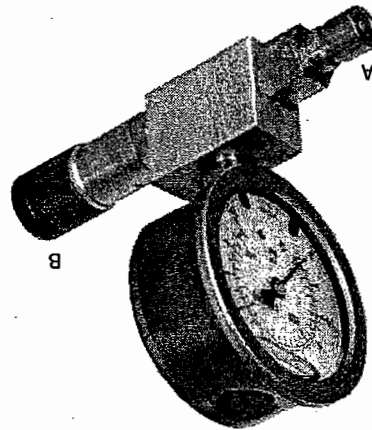

Pressure gauge

152841



Pressure-drop/flow-rate characteristic for various rotary-knob settings (division lines)

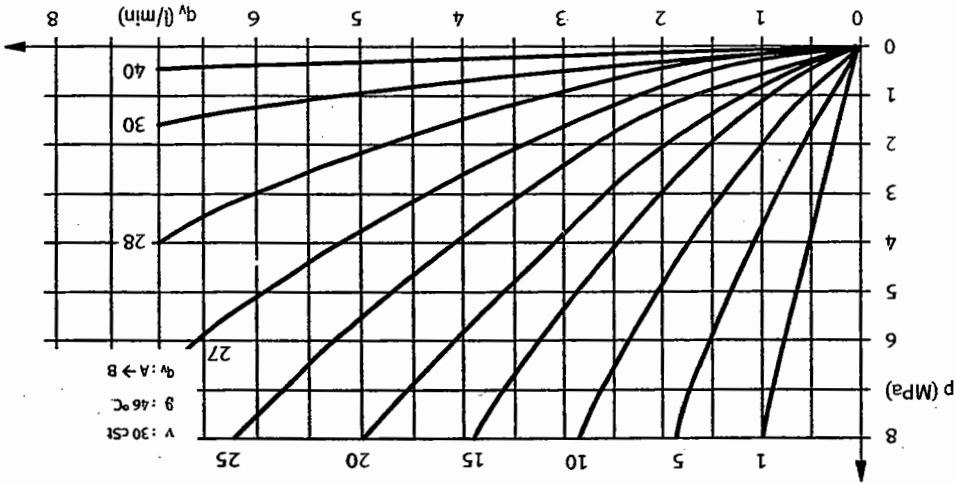

In both directions, from A to B and B to A, hydraulic fluid flows through the throttle point (3), the size of which can be adjusted by means of the rotary knob.

Function

Valve housing (1), rotary knob (2), throttle point (3), nipple (A), socket (B).

Design

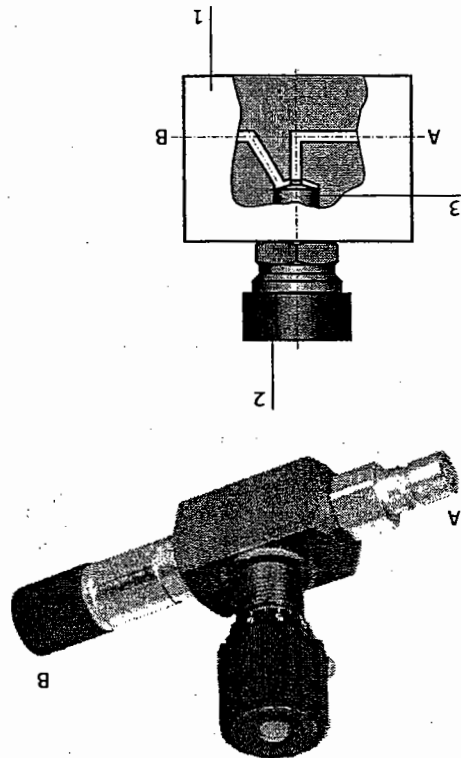

<b>Hydraulic</b>	
Medium	Mineral oil, recommended viscosity 22 cSt (mm <sup>2</sup> /s)
Operating pressure	6 MPa (60 bar)
Max. permissible pressure p <sub>max</sub>	12 MPa (120 bar)
Nominal flow rate	9 l/min
Actuation	Manual
Connections	For coupling nipple/socket

Note

The valve ports identified by letters A and B are the working ports.

Function

A one-way flow control valve is a combination of a throttle valve and non-return valve. In the flow direction from A to B, the hydraulic fluid flows only through the throttle point (3), the size of which is adjustable by means of the rotary knob (2). The valve seat (4) is closed by the sealing ball (5) and the spring (6). In the opposite direction, the non-return valve is open and the full flow cross-section is available.

Design

Valve housing (1), rotary knob (2), throttle valve (3), valve seat (4), sealing ball (5), spring (6), nipple (A), socket (B).

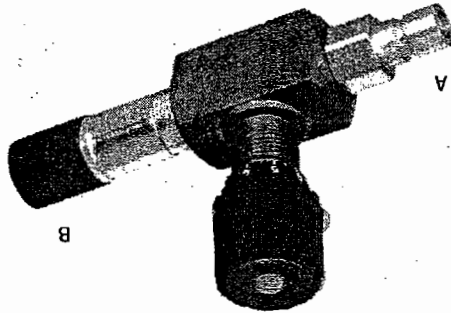
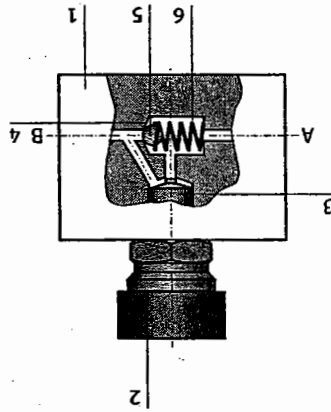

One-way flow control valve

152843

Technical data

Hydraulic	
Medium	Mineral oil, recommended viscosity 22 cSt (mm <sup>2</sup> /s)
Operating pressure p	6 MPa (60 bar)
Max. permissible pressure P <sub>max</sub>	12 MPa (120 bar)
Nominal flow rate	9 l/min
Opening pressure	70 kPa (0.7 bar)
Actuation	Manual
Connections	For coupling nipple/socket

Pressure-drop/flow-rate characteristic for various rotary-knob settings

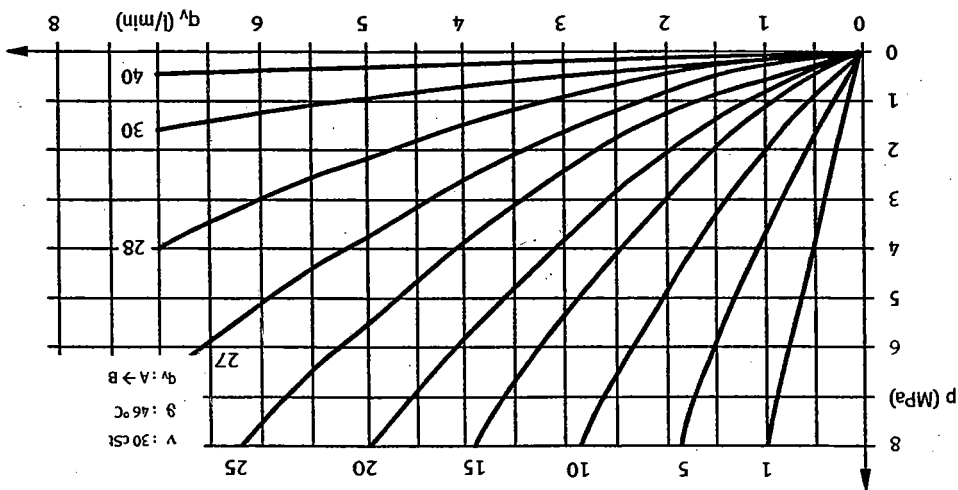

One-way flow control valve

152843



<b>Hydraulic</b>	
Medium	Mineral oil, recommended viscosity 27cSt (mm <sup>2</sup> /s)
Operating pressure p	6 MPa (60 bar)
Max. permissible pressure p <sub>max</sub>	12 MPa (120 bar)
Actuation	Manual
Connections	For coupling nipple/socket

Technical data

Note  
In order to reduce leakage during coupling, the shut-off valve should always be open when being coupled up.

Pressure-drop/flow-rate characteristic

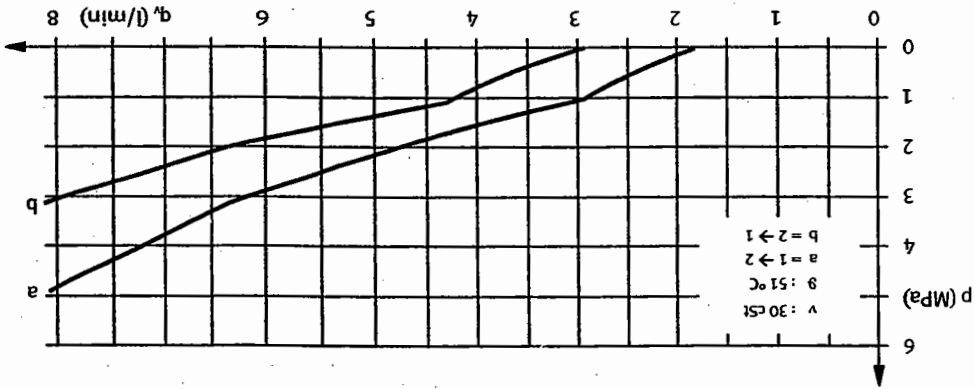

Function  
The shut-off valve can be interposed at any point in the circuit to allow flow to be interrupted by means of the shut-off lever.

Design  
Shut-off valve with two connections.

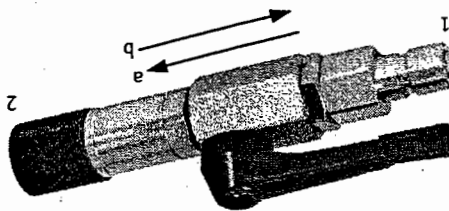

Shut-off valve

152844



Circuits must always be depressurised before a non-return valve is coupled up. It is not possible in this case to release pressure by means of the pressure relief device (Order no. 152971).

A non-return valve prevents flow in one direction, while allowing free flow in the opposite direction. In the closed position, the spring (3) presses the sealing ball (2) onto the valve seat. Flow begins when the pressure in the flow direction exceeds a value of approx. 1 bar or 5 bar. The sealing ball (2) is then lifted off the valve seat against the force of the spring (3).

Housing (1), sealing ball (2), spring (3), nipple (A), socket (B)

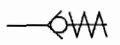
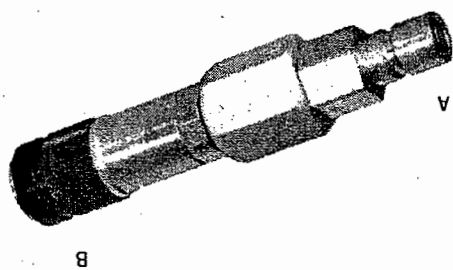
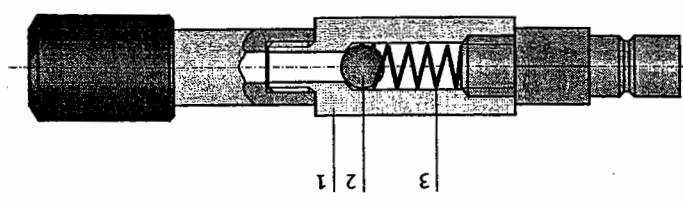

152845, 152846  
Non-return valve, 1 bar, 5 bar

Note

Function

Design

Technical data

Hydraulic	152845	152846
Medium	Mineral oil, recommended viscosity 22 cSt (mm <sup>2</sup> /s)	
Operating pressure p	6 MPa (60 bar)	
Max. permissible pressure p <sub>max</sub>	12 MPa (120 bar)	
Opening pressure	0.1 MPa (1 bar)	0.5 MPa (5 bar)
Actuation	Hydraulic	
Connections	For coupling nipple/socket	

Pressure-drop/flow-rate characteristic

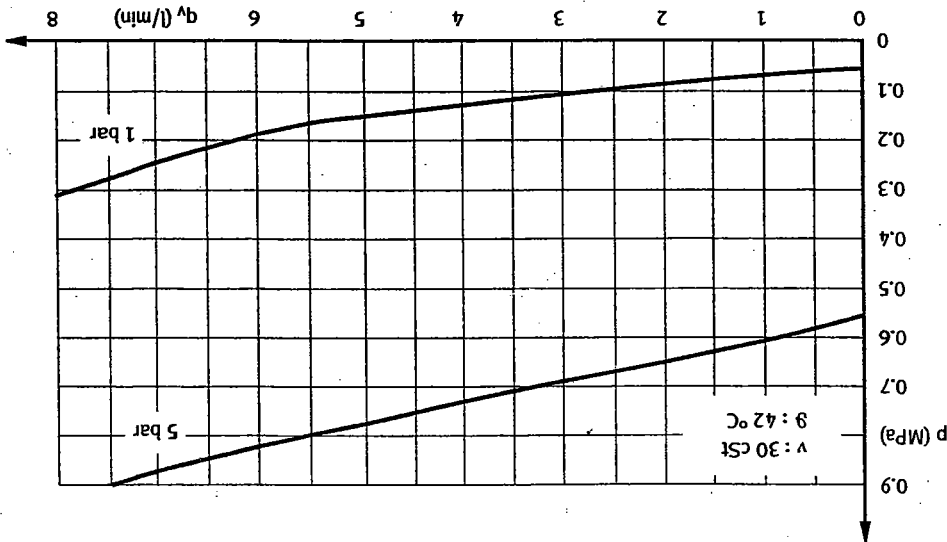

Non-return valve, 1 bar, 5 bar

152845, 152846

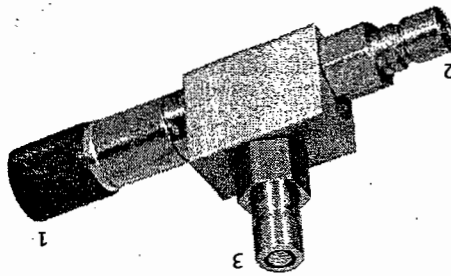

Branch tee with 3 connections (1 = socket, 2 and 3 = nipples).

This component can be fitted at any desired point to create a branch.

Design  
Function

Pressure-drop/flow-rate characteristic

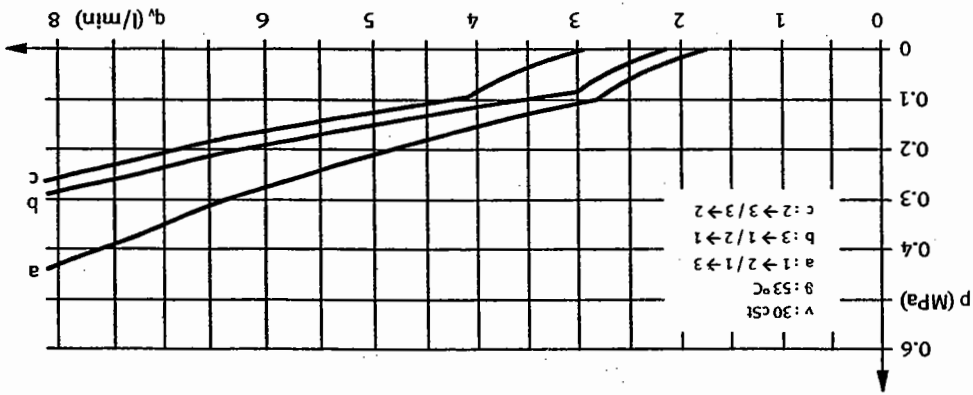

Technical data

Hydraulic	
Medium	Mineral oil, recommended viscosity 22 cSt (mm <sup>2</sup> /s)
Operating pressure p	6 MPa (60 bar)
Max. permissible pressure p <sub>max</sub>	12 MPa (120 bar)
Connections	For coupling nipple/socket



Function

Used as a pressure-relief valve, this valve limits the pressure at port P and any excess oil is discharged into the tank.

In the form of a pressure sequence valve, it connects the consuming devices at port T once the pressure set at P has been reached.

This valve is normally closed. If the force from the differential pressure of port P and T, times the front surface area of the piston, is greater than the spring force, the sealing cone (1) lifts off the valve seat (2), and the hydraulic fluid is discharged via port T. The valve closes again once the pressure at port P diminishes. The cushioning piston, similar to a shock absorber, ensures greater stability.

Design

The pressure relief valve is mounted on a function plate equipped with two quick coupling connectors. The component is fitted to the grid system of the slotted assembly board by means of the two blue levers (mounting variant "A").

The valve consists of:

- Sealing cone (1), valve seat (2), spring (3), rotary knob (4), lock nut (5), screw spindle (6), spring disc (7), cushioning piston (8).

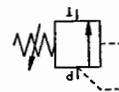
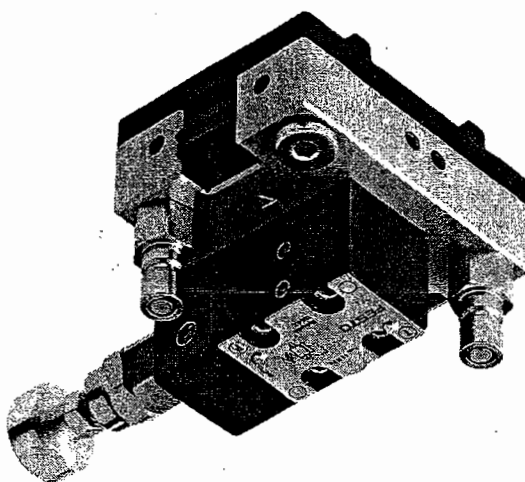
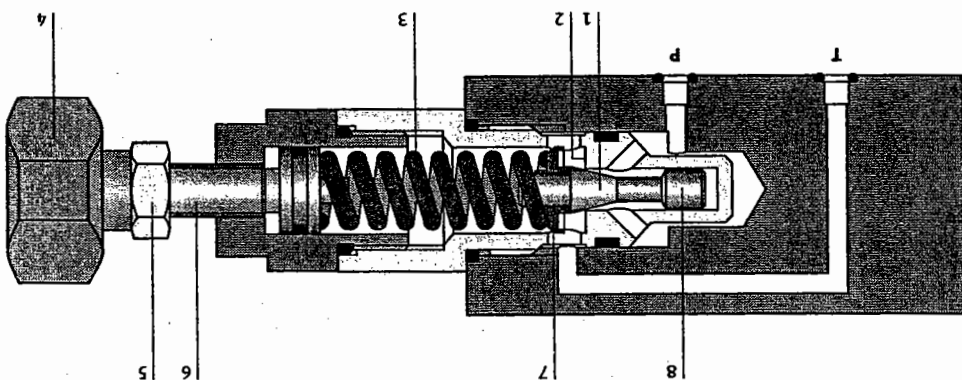

Pressure relief valve, Pressure sequence valve

152848

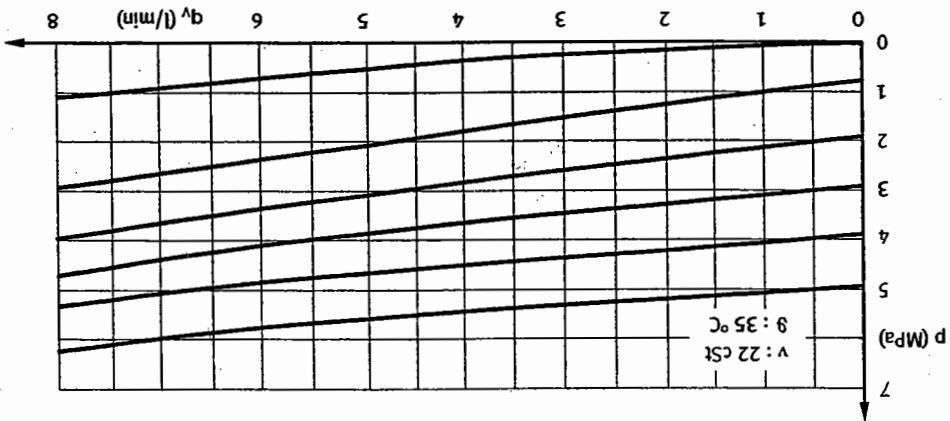

Pressure/flow-rate characteristic for various rotary-knob settings

Note

The valve ports are identified by letters.  
 P Supply port  
 T Return-line port (tank connection)

Technical data

Hydraulic	
Medium	Mineral oil, recommended viscosity 22 cSt (mm <sup>2</sup> /s)
Operating pressure p	60 bar (6 MPa)
Max. permissible pressure p <sub>max</sub>	120 bar (12 MPa)
Adjustment	Manual
Actuation	Hydraulic
Connections	Via 2 coupling sockets



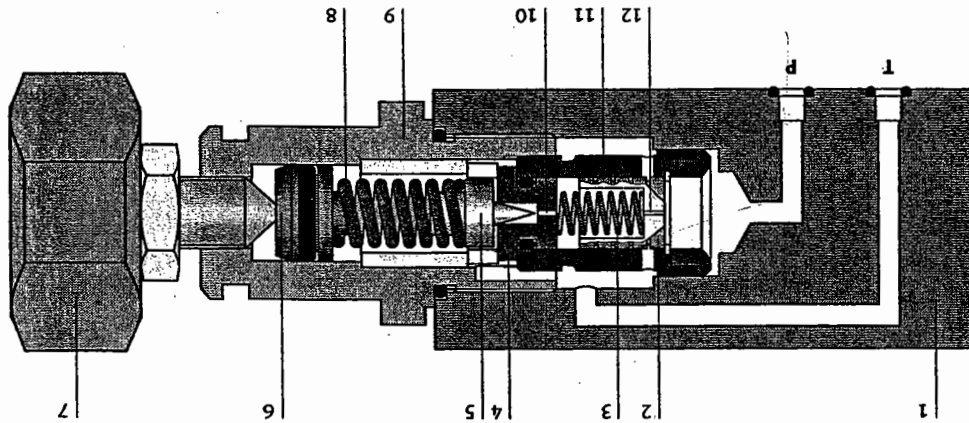
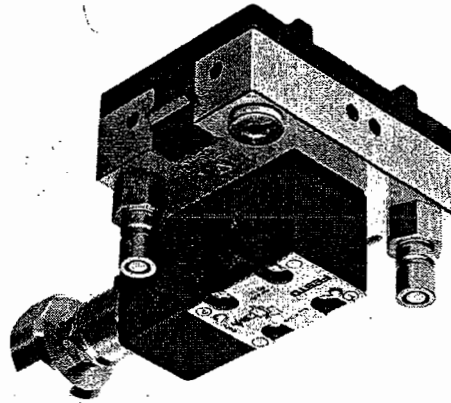
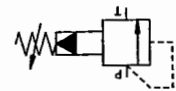

Design

The pressure relief valve is mounted on a function plate with two quick coupling connectors. The component is fitted to the grid system of the slotted assembly board plate by means of the two blue levers (mounting variant "A").

The valve consists of:

- Housing (1), piston (2), spring (3), cone seat (4),
- sealing cone (5), spring disc (6), adjusting screw (7),
- spring (8), cartridge housing (9), throttling nozzle (10),
- main control sleeve (11), throttling nozzle (12).

Function

The piloted pressure relief valve limits the pressure at port P to a set value. The main stage is controlled by means of a small volumetric flow rate in the pilot stage, whereby the pressure of much higher volumetric flow rates can be limited than would be possible with a directly actuated valve. The pressure is applied at the sealing cone (5) by means of the P channel via the two throttle nozzles (10 + 12). The pressure at port T prevails in the spring chamber. The sealing cone to the spring chamber opens if the force from the differential pressure and active surface of the cone is greater than the set spring force (8).

The volumetric flow rate passing over the cone seat (pilot stage) creates a pressure drop via the throttling nozzle (12). The pressure upstream and downstream of the piston (2) is therefore no longer the same. The piston is pressed against the spring (3) with the resulting force and opens towards the main control sleeve. The combination of the two control nozzles in conjunction with the opening characteristics of the main piston determine the amplification of the pilot control. The greater the amplification, the flatter the flow characteristic curve. The extent of amplification is limited by the stability of the valve and its working range. In this case, the amplification is small due to the very small flow rates, so that the advantage over the directly actuated pressure relief valve is not so clearly apparent.

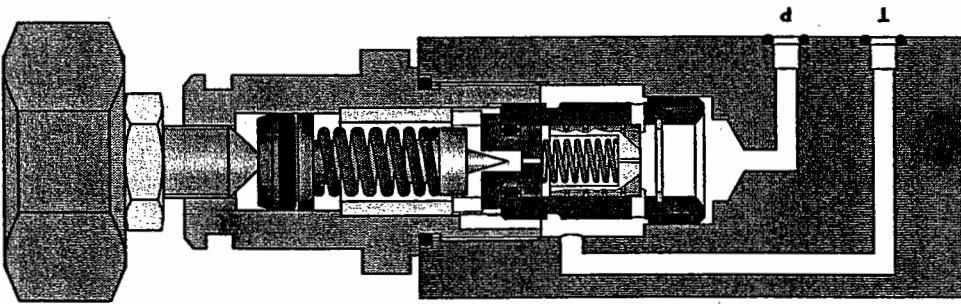

The valve ports are identified by letters.

P Supply port

T Return-line port (tank connection)

Note

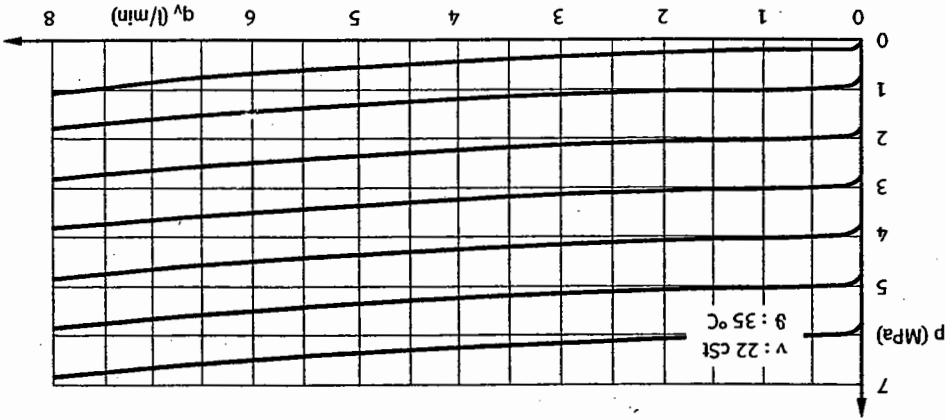

Pressure/flow-rate characteristic for various rotary-knob settings

152849

Pressure relief valve, piloted

Technical Data

Hydraulic	
Medium	Mineral oil, recommended viscosity 22 cSt (mm <sup>2</sup> /s)
Operating pressure p	60 bar (6 Mpa)
Max. permissible pressure P <sub>max</sub>	120 bar (12 MPa)
Adjustment	Manual
Action	Hydraulic
Connections	Via 2 coupling sockets



152850

3-way pressure reducing valve

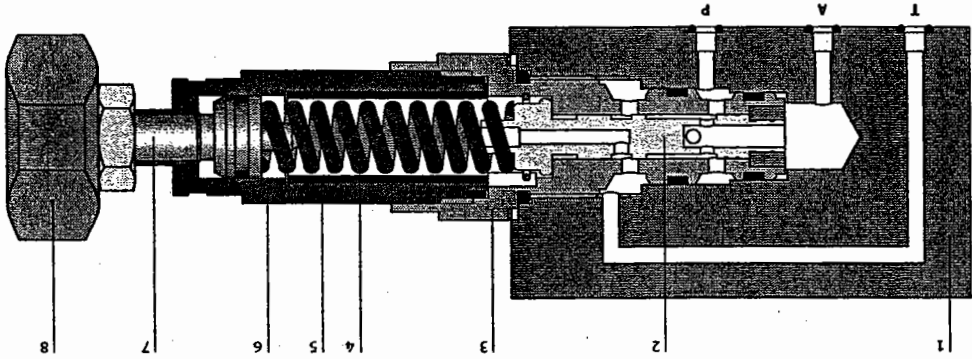
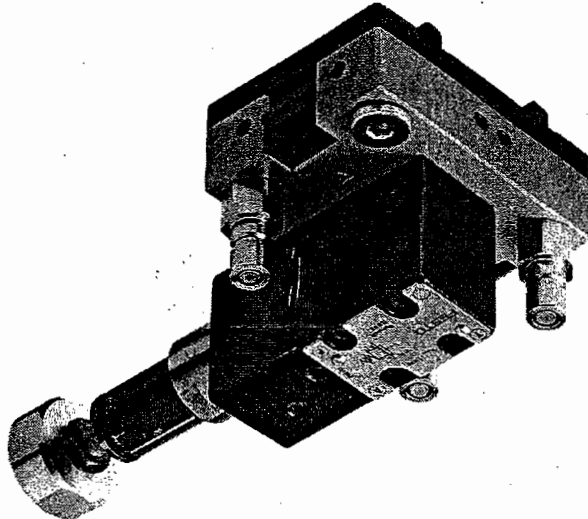
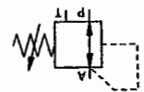

Design

The 3-way pressure reducing valve is mounted on a function plate equipped with three quick coupling connectors. The component is fitted to the grid system of the slotted assembly board by means of the two blue levers (mounting variant "A"). The valve consists of: Valve body (1), piston (2), cartridge housing (3), spring (4), guide sleeve (5), cartridge cover (6), adjusting screw (7), rotary knob (8).

Function

The function of the 3-way pressure reducing valve is to maintain a constant set pressure at port A, against fluctuating supply pressures and loads from consuming devices. This valve is a combination of a pressure reducing valve and pressure relief valve. The pressure applied at port A acts across the surface of the piston (2) against the spring force. The piston (2) is pressed against the spring until an equilibrium is reached. The spring force can be changed via the adjusting screw (7) by turning the rotary knob (8).

When the set pressure is reached at A, the position of the piston (2) is such that neither a connection to the P or the T connection exists. The piston (2) is now in the mid position.  
 If the pressure at A drops, the spring (4) pushes back the piston (2), thereby opening a passage to P port so that oil can flow through.  
 If the pressure at A increases, the piston (2) is further pushed against the spring (4). This opens a connection to port T and oil can escape.

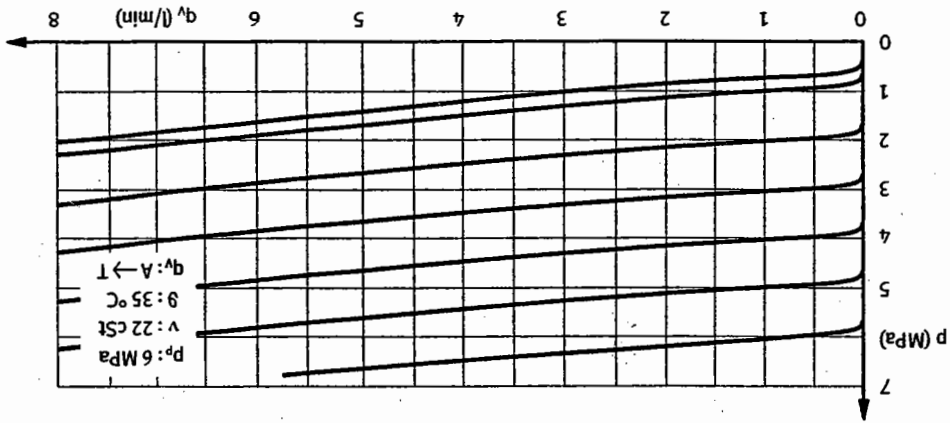
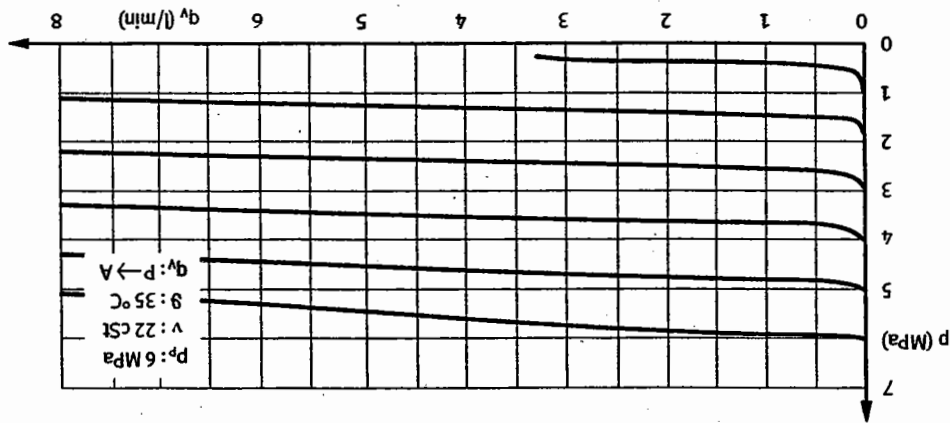

152850

3-way pressure reducing valve

The valve ports are identified by letters.

- A Working port
- P Supply port
- T Return-line port (tank connection)

Technical Data

Hydraulic	
Medium	Mineral oil, recommended viscosity 22 cSt (mm <sup>2</sup> /s)
Operating pressure p	60 bar (6 Mpa)
Max. permissible pressure p <sub>max</sub>	120 bar (12 Mpa)
Adjustment	Manual
Action	Hydraulic
Connections	Via 3 coupling sockets





Function

The flow control valve ensures a regular volumetric flow independent of the load pressure of the consuming device. Pressure is applied to the working piston (1) on the spring chamber side via a cushioning throttle. At the same time, oil flows from port P via the adjustable flow control valve to the other side of the piston and from there via a hole to connection A. The pressure downstream of the adjustable throttle point is less than the pressure at port P and therefore also less than the pressure in the

Design

The 2-way flow control valve is mounted on a function plate equipped with 2 quick coupling connectors. The component is fitted to the grid system of the slotted assembly board by means of the two blue levers (mounting variant "A"). The valve consists of: Control piston (1), spring (2), adjustable spindle throttle point (3), adjusting spindle (4), rotary knob (5), lock nut (6), control piston throttle point (7), pilot hole (8).

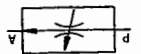
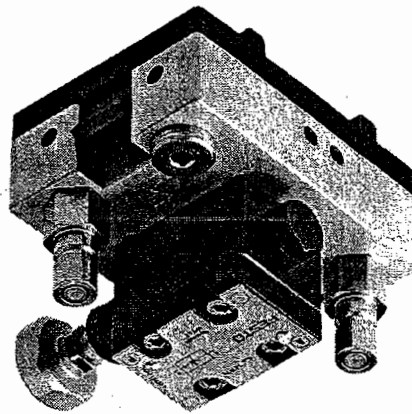
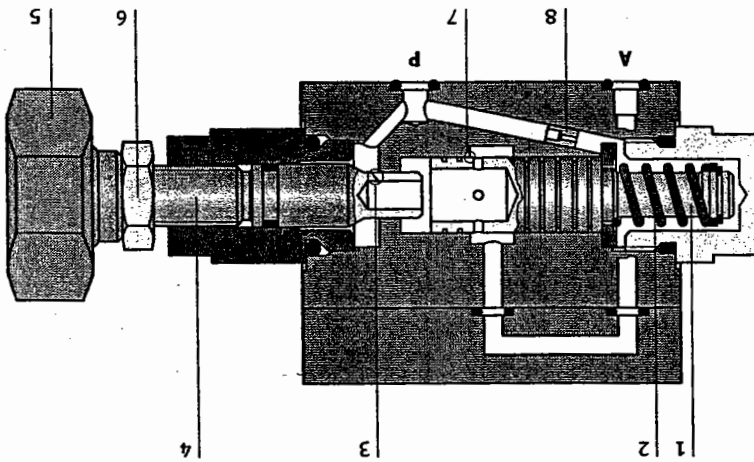

2-way flow control valve

152851

spring chamber. As a result of this the piston is pushed against the spring force to the right and restricts the discharge to port A. The differential pressure between port P and the pressure downstream of the adjustable flow control valve thereby remains constant and the volumetric flow rate flowing via the flow control valve constant.

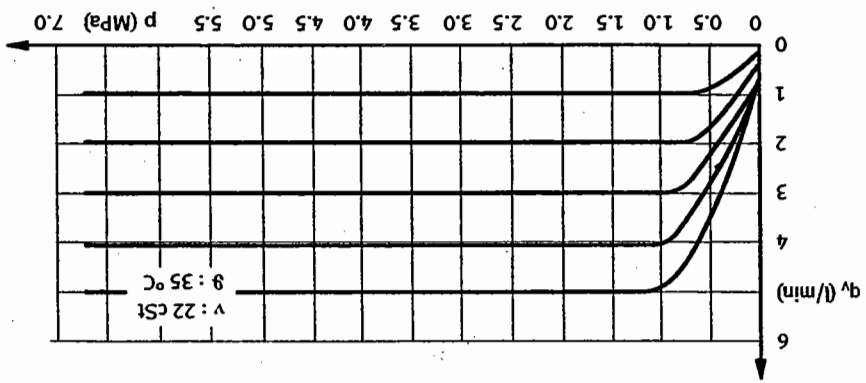

Flow-rate/pressure-drop characteristic for various rotary-knob settings

Note  
The valve ports are identified by letters.  
P Supply port  
A Working port

Technical data

Hydraulic	
Medium	Mineral oil, recommended viscosity 22 cSt (mm <sup>2</sup> /s)
Operating pressure p	60 bar (6 Mpa)
Max. permissible pressure p <sub>max</sub>	120 bar (12 Mpa bar)
Adjustment	Manual
Action	Hydraulic
Connections	via 2 coupling sockets

Function

A hydraulically piloted non-return valve is used when a hermetic seal is required in one direction. In contrast to the case of a normal non-return valve, it is possible with this valve to enable flow in the non-return direction by applying pressure at port X.

Design

This hydraulically piloted non-return valve is mounted on a function plate equipped with three connection nipples. The component is fitted to the grid system of the profile plate by means of the two blue levers (mounting variant "A"). The valve consists of the following: Housing (1), release piston (2), valve seat (3), sealing cone (4), spring (5), cartridge (5), housing (6).

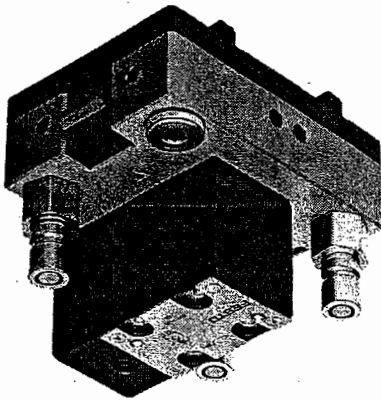
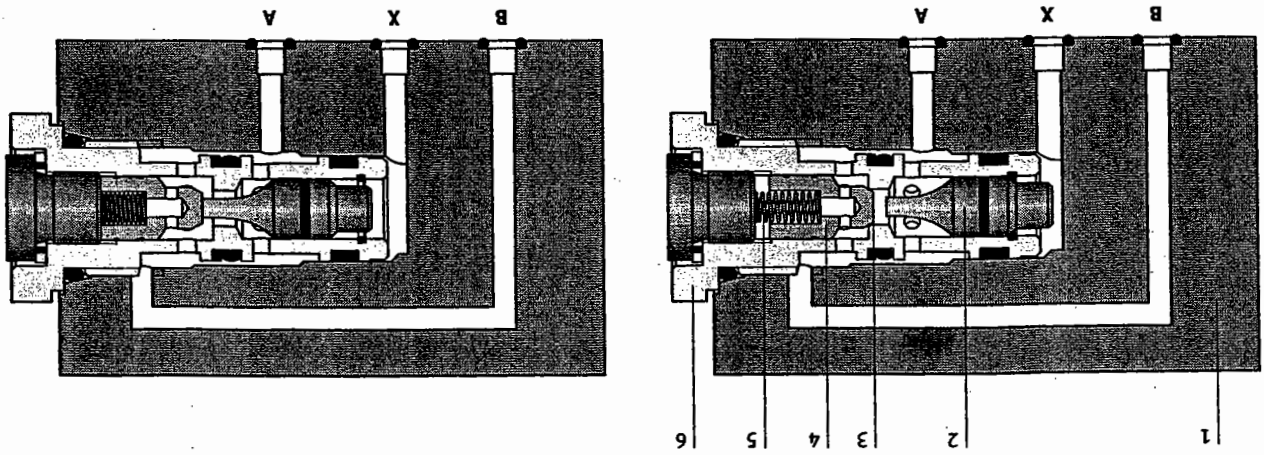

Non-return valve, piloted

152852

The sealing cone (4) is pressed lightly against the tapered seat (3) by the spring (5). As soon as the pressure at port A becomes even slightly higher than that at port B, flow in the opposite direction is closed by the sealing cone (4), which is pressed against the tapered seat by the spring force and also the higher pressure at port B, thus blocking flow. This part of the valve behaves like a normal non-return valve. In order to enable flow in the non-return direction, the pressure at port X must be higher in accordance with the ratio of the areas of the tapered seat (3) and the release piston (2). The release piston (2) will then open the sealing cone (4).

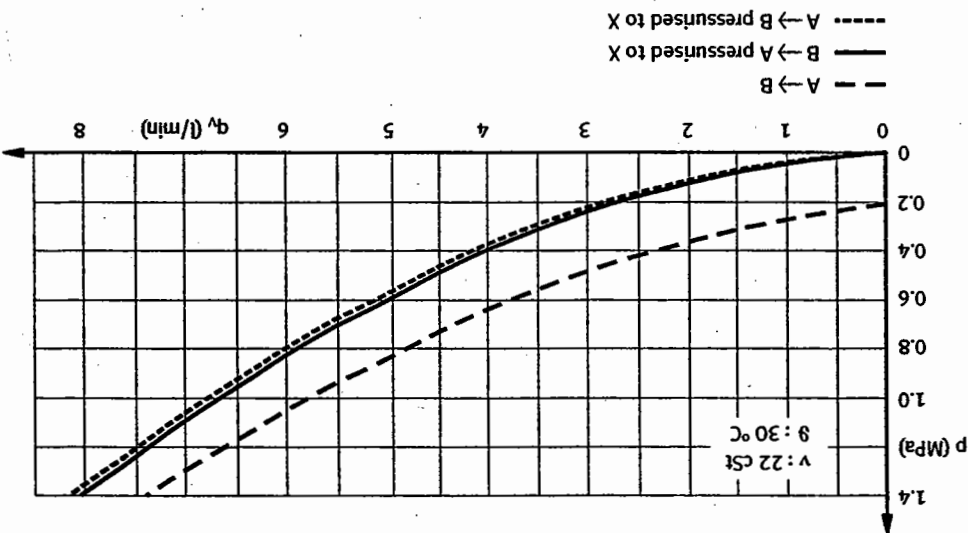

Note

The valve ports are identified by letters:  
 A, B Working ports  
 X Pilot port

Difficulty may be experienced making connections to port B using quick couplings. In one coupling operation, it is necessary to displace fluid behind the coupling nipple. However, the fluid is not able to drain away due to the hermetic seal of the non-return valve. The remedy is as follows: Pressurise port X to a very low level of approx. 0.5 Mpa. This will release the non-return valve, and the quick coupling socket can now be connected to port B without difficulty.

Technical data

<b>Hydraulic</b>	
Medium	Mineral oil, recommended viscosity 22 cSt (mm <sup>2</sup> /s)
Operating pressure p	6 MPa (60 bar)
Max. permissible pressure p <sub>max</sub>	12 MPa (120 bar)
Actuation	Hydraulic (3 : 1)
Connections	For 3 coupling sockets

Non-return valve, piloted

152852



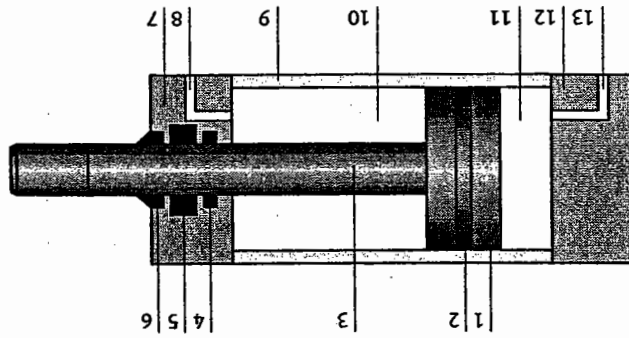
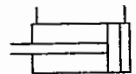
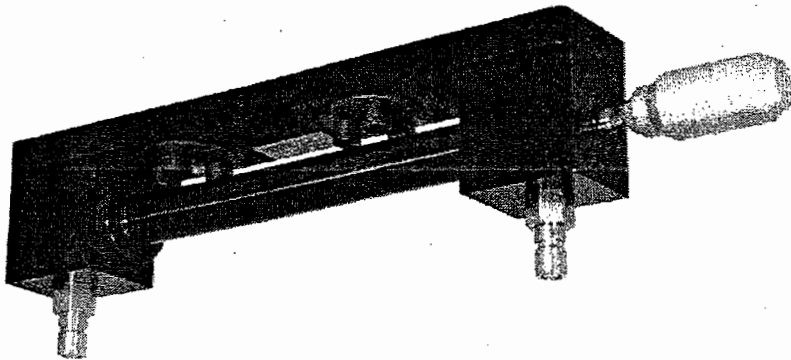

Design

This double-acting cylinder is equipped with a switching cam and two barbed fittings and is mounted on a mounting plate. The unit is secured to the profile panel by the twist-lock system using two blue finger nuts (mounting variant "B").

The cylinder consists of: Piston (1), piston seal and guide (2), piston rod (3), piston rod bearing (4), piston rod seal (5), scraper ring (6), cylinder cap (7), connections (8 and 13), cylinder barrel (9), piston rod chamber (10), piston chamber (11), cylinder base (12).

Function

The piston chamber (11) is pressurised via connection (13). The action of the pressure on the piston surface produces a force which sets the piston in motion. This causes oil to be displaced from the piston rod chamber; the oil is discharged via connection (8). In order to retract the piston again, the piston rod chamber (10) is pressurised via connection (8). The displaced oil is discharged in this case via connection (13). The piston seal (2) acts as a divider between the two chambers, while the piston guide supports the piston. The piston rod seal (5) provides a seal between the piston rod chamber (10) and the surrounding environment. The scraper ring (6) keeps the rod seal (5) free of contamination. The piston rod bearing (4) guides and supports the piston rod.

**152857, 184489, 184488**

Cylinder 16/10/200, 16/10/300, 16/10/400

Note

If the cylinder is used in conjunction with the weight (Order no. 152972), ensure that the cylinder is fully secured. For additional safety, the cover (Order no. 152973) can be used with the cylinder (Order no. 152857).

Technical data

Cylinder version (Order no.)	152857	184489	184488
Medium	Mineral oil, recommended viscosity 22 cSt (mm <sup>2</sup> /s)		
Piston diameter	16 mm		
Piston rod diameter	10 mm, with M 8		
Stroke	200 mm	300 mm	400 mm
Operating pressure p	6 MPa (60 bar)		
Max. permissible pressure p <sub>max</sub>	12 MPa (120 bar)		
Connections	To accept 2 connector sockets		



Design

This hydraulic motor is mounted on a mounting plate. The component is fitted to the profile plate using the rotary system by means of two blue grip nuts (mounting variant "B").

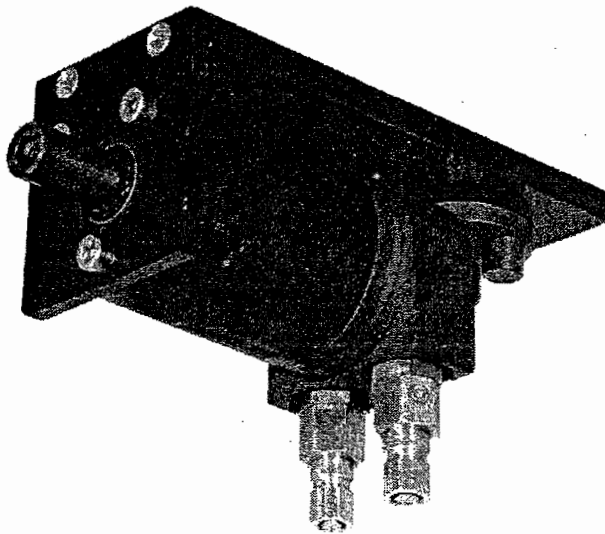

simplified symbol

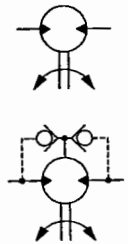

Function

The direction of rotation changes with the flow direction. The hydraulic fluid is supplied at one of the connections. The external gear (5) is hereby placed into rotation and drives the shaft (7) via the cardan shaft (6). The alternate supply and discharge of the volumetric flow rate is controlled via the collector and the control ducts of the housing. The leakage in the motor is fed to the low pressure connection (3) via the shuttle valve (4).

The motor consists of:  
 Housing with control ducts (1), fixed, internal gear (2),  
 connections (3), shuttle valve (4), external gear (5),  
 cardan shaft (6), shaft with collector part (7).

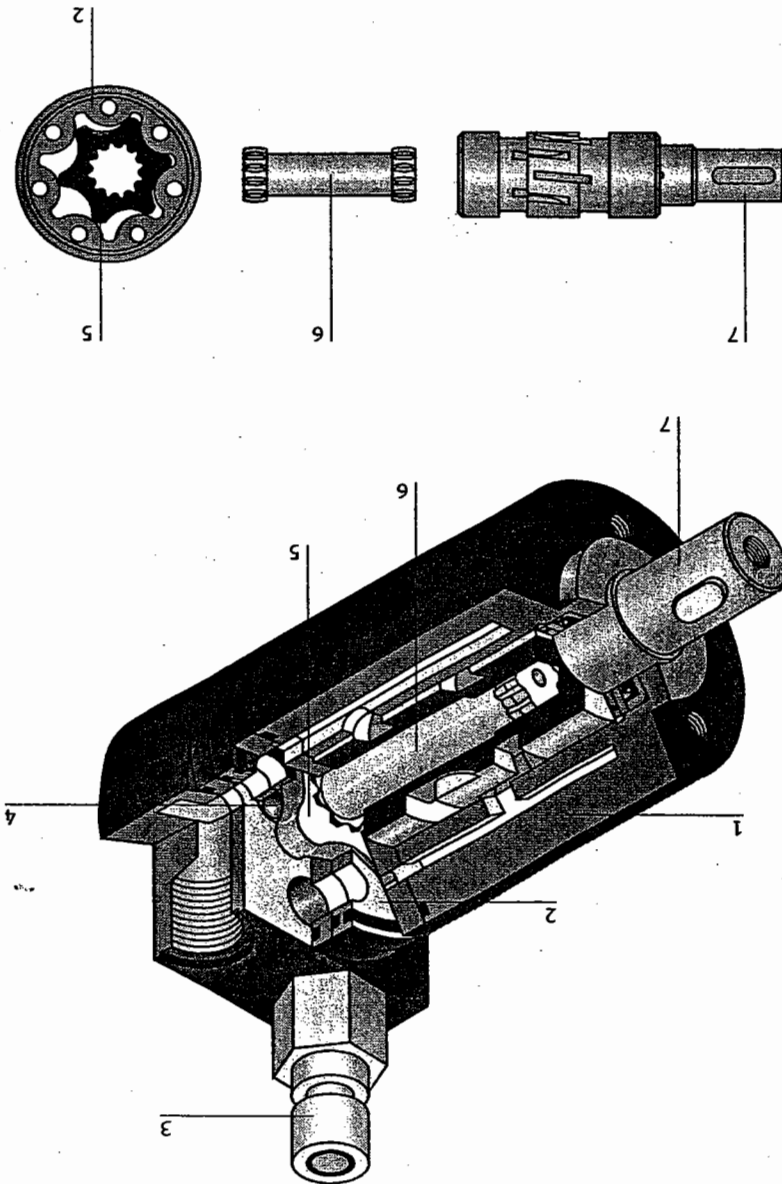

Hydraulic	
Medium	Mineral oil, recommended viscosity 22 cst (mm <sup>2</sup> /s)
Design	Orbital
Geometric displacement	8.2 cm <sup>3</sup>
Operating pressure p	6 MPa (60 bar)
Max. permissible pressure p <sub>max</sub>	12 MPa (120 bar)
Max. permissible pressure in return line	5 MPa (50 bar)
P <sub>r max</sub>	
Max. rotary speed n <sub>max</sub>	1950 min <sup>-1</sup>
Output shaft with spring	Ø 16 x 28, A5 x 5 DIN 6885
Max. permissible shaft load	radial: 1600 N axial: 800 N
Connections	For 2 coupling sockets

Technical data

Torque/rotary-speed characteristic

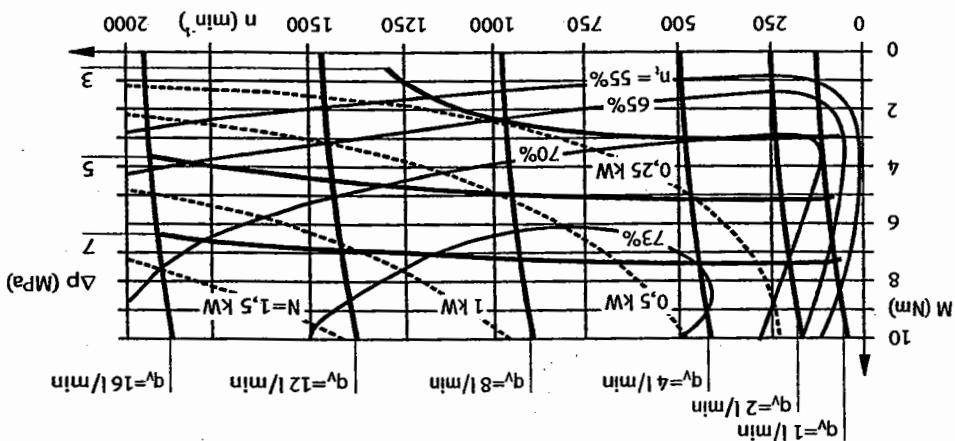

end of the shaft.

The flow-rate/rotary-speed indicator PN 183736 can be attached using the top cheese-head bolt. Before doing this, however, screw the coupling adapter into the

Note

Hydraulic motor

152858



**Section A – Course**

- Exercise 1: Automatic lathe Pump characteristic A-3
- Exercise 2: Package lifting device Pressure relief valve characteristic A-7
- Exercise 3: Drawing press Hydraulic resistances A-11
- Exercise 4: Calender feeding device Single-acting cylinder (basic circuit) A-15
- Exercise 5: Hardening furnace Single-acting cylinder (measurement and calculation) A-19
- Exercise 6: Furnace door control Double-acting cylinder A-23
- Exercise 7: Conveyor tensioning device 4/3-way valve with bypass to pump A-29
- Exercise 8: Cold-store door Accumulator A-33
- Exercise 9: Rotary machining station Flow control valve and counter-holding A-37
- Exercise 10: Painting booth Flow control valve characteristic A-41
- Exercise 11: Embossing machine One-way flow control valve and counter-holding A-45
- Exercise 12: Surface grinding machine Differential circuit A-49
- Exercise 13: Drilling machine Pressure regulator A-55
- Exercise 14: Bulkhead door Hydraulic clamping of a cylinder A-59

A-63	Exercise 15: Ferry loading ramp Flow control valve in inlet and outlet lines
A-69	Exercise 16: Skip handling Varying load
A-73	Exercise 17: Bonding press Comparison of pressure regulator and – pressure relief valve
A-77	Exercise 18: Assembly device Pressure sequence circuit, displacement-step diagram
A-81	Exercise 19: Assembly device Calculation of pressure and time
A-85	Exercise 20: Tipping container Electrohydraulics

Hydraulics	Automatic lathe
Subject	Title
Training aim	■ To teach the student how to draw the characteristic curve for a pump
Problem definition	■ Drawing the hydraulic circuit diagram ■ Practical assembly of the circuit ■ Determining the various measured values and entering them into the table ■ Drawing the characteristic curve for the pump ■ Drawing conclusions

Exercise

The main spindle on an automatic lathe is driven by a hydraulic motor, while a hydraulic cylinder is used to execute a feed movement of the workpiece slide. It has been established that the specified speed is no longer reached during the processing cycle. The pump characteristic curve is therefore to be evaluated.

Positional sketch

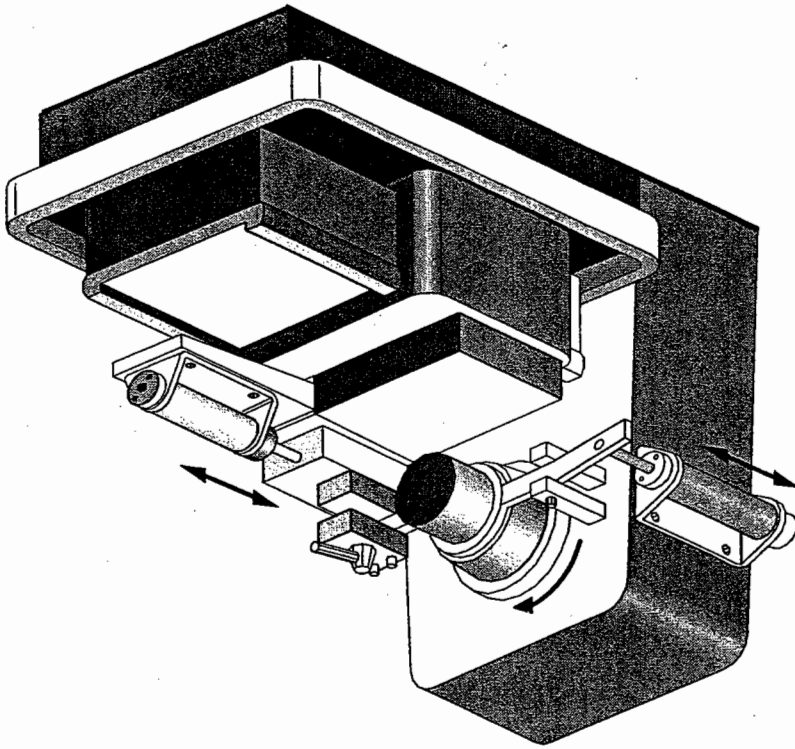



---



---



---

How does the flow rate change as the pressure increases?

Conclusion

Pump characteristic

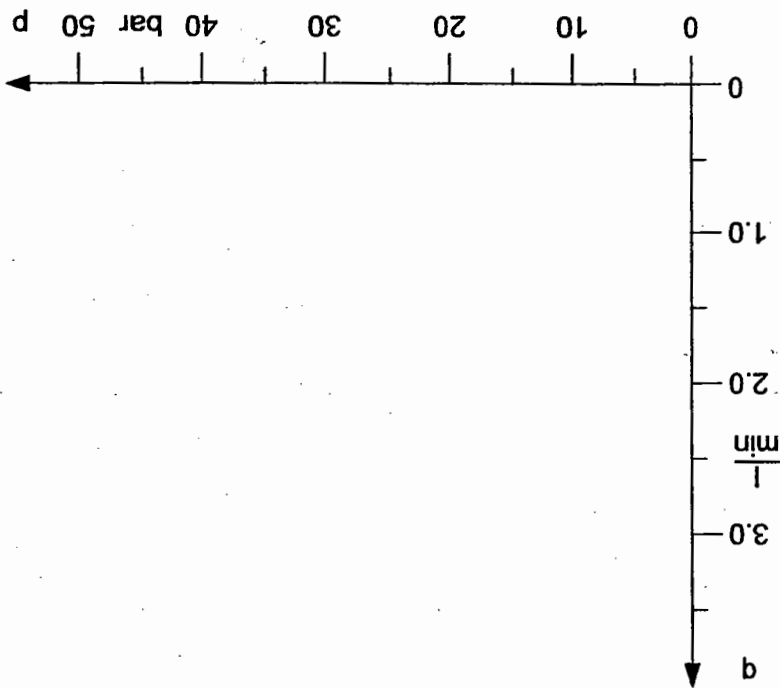

System pressure p	Flow rate q
15	
20	
25	
30	
35	
40	
45	
50	

Evaluation

**EXERCISE SHEET**



**Package lifting device**

Hydraulics

- To teach the student how to draw the characteristic for a pressure relief valve

Training aim

- Drawing the hydraulic circuit diagram
- Practical assembly of the circuit
- Setting a maximum pressure of 50bar
- Establishing the opening pressure of the pressure relief valve
- Determining the various measured values and entering them into the table
- Drawing the pressure/flow rate characteristic
- Drawing conclusions

Problem definition

Subject

Title

Exercise

Owing to a change in the production process, a package lifting device is now required to lift heavier packages than those for which it was originally designed. It has been observed that the stroke speed is now lower. Using the pressure/flow rate characteristic for the pressure relief valve, determine the pressure at which flow diversion of the pump output begins.

Positional sketch

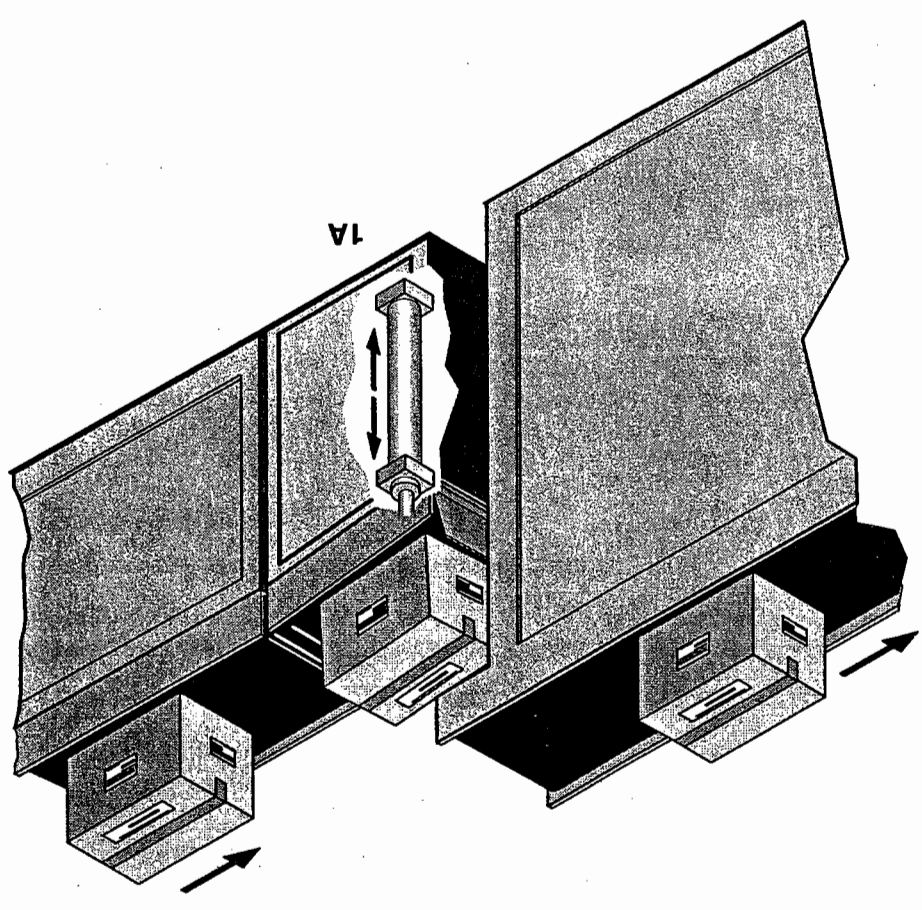

---



---



---

How great is the difference between the opening pressure and maximum pressure?  
 Conclusion

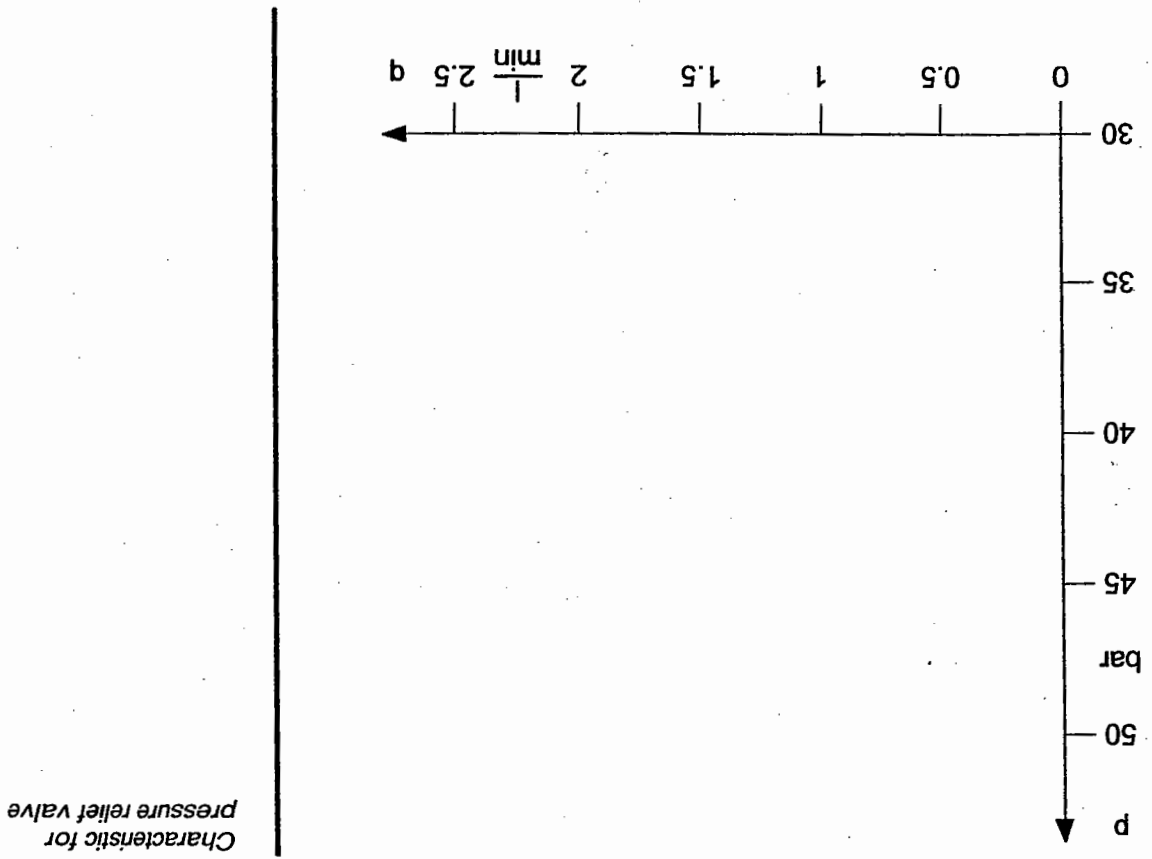

Characteristic for pressure relief valve

Working pressure p	Flow rate q
35	
40	
42.5	
45	
47.5	
50	

Evaluation

**EXERCISE SHEET**



Hydraulics

Drawing press

- To teach the student how to measure flow resistances
- Drawing the hydraulic circuit diagram
- Practical assembly of the circuit
- Setting a constant flow rate
- Measuring the flow resistances
- Drawing conclusions

Subject

Title

Training aim

Problem definition

Exercise

A drawing press is used to shape metal workpieces. Following modification of the hydraulic system, the workpieces are no longer dimensionally accurate. The reason for this may be that the required press pressure is not being reached. Use a special test set-up to measure the hydraulic resistance of the components used.

Positional sketch

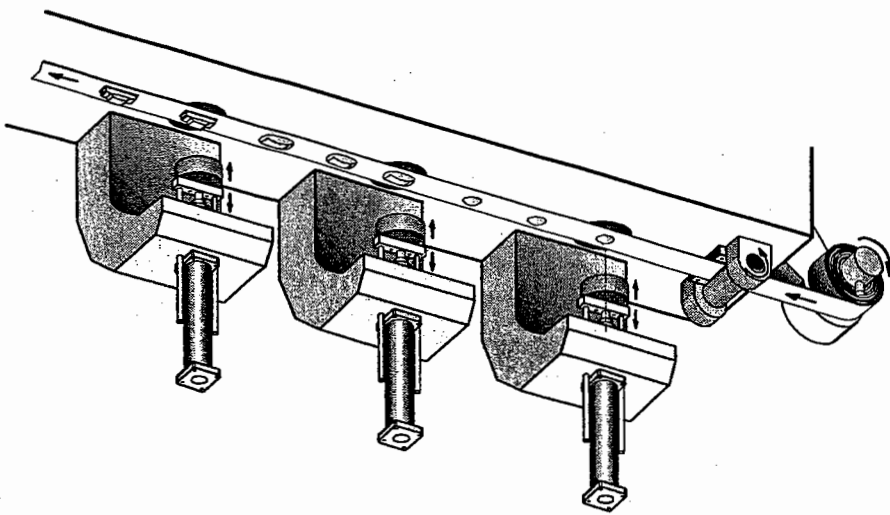



**EXERCISE SHEET**

$p_{0z3}$  = Pressure upstream of component  
 $p_{0z4}$  = Pressure downstream of component

Evaluation

Values table

Component	Flow rate $q$ l/min	Pressure $p_{0z3}$ bar	Pressure $p_{0z4}$ bar	Pressure difference $\Delta p$ bar
Pressure relief valve, fully open	2			
Pressure relief valve, fully open	1			
Throttle valve, fully open	2			
Throttle valve, fully open	1			
4/2-way valve, $P \rightarrow A$	2			
4/2-way valve, $P \rightarrow A$	1			
4/3-way valve, $P \rightarrow A$	2			
4/3-way valve, $P \rightarrow A$	1			

How does the pressure difference change when the flow rate is doubled?  
 Conclusion

---



---



---



---



---



Hydraulics

Calendar feeding device

- To familiarise the student with the applications of a non-return valve
- To show the activation of a single-acting cylinder using a 2/2-way valve

- Drawing the hydraulic circuit diagram
- Practical assembly of the circuit
- Evaluation of this circuit

Problem definition

Training aim

Subject

Title

Exercise

Rolls of paper are lifted into a calendar by a lifting device. The lifting device is driven by a plunger cylinder (single-acting cylinder). When the hydraulic power pack is switched on, the pump output flows directly to the cylinder. A 2/2-way valve, which is closed in its normal position, is fitted in a branch line leading to the tank. A non-return valve is used to ensure that the pump is protected against the oil back-pressure. A pressure relief valve is fitted upstream of the non-return valve to safeguard the pump against excessive pressures.

Positional sketch

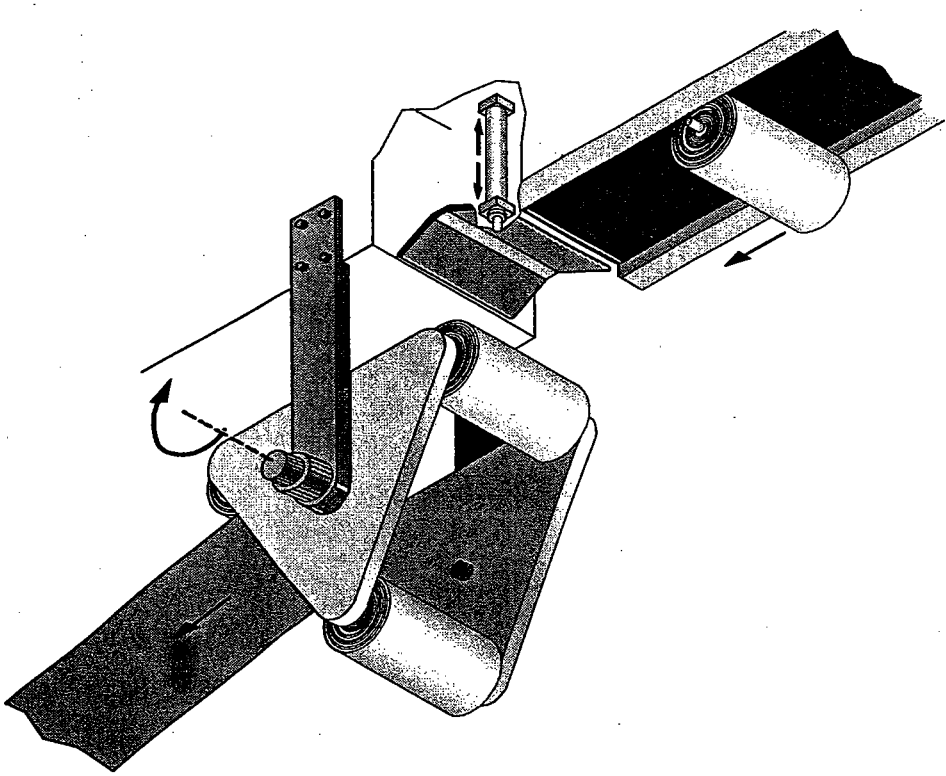

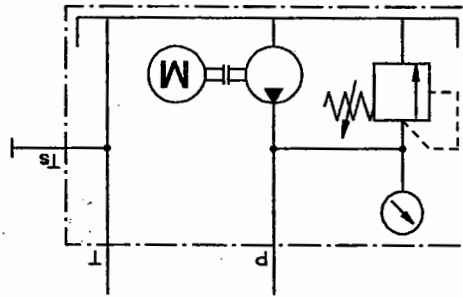

**EXERCISE SHEET**

Circuit diagram, hydraulic

---

---

---

---

---

*Conclusion* What is the disadvantage of this circuit?

<i>Components list</i>	Item no.	Qty.	Description

**Hardening furnace**

Hydraulics

Subject

Title

Training aim

- To familiarise the student with the applications of a 3/2-way valve
- To show how to determine times, pressures and forces during the advance and return strokes of a single-acting cylinder

Problem definition

- Drawing the hydraulic circuit diagram
- Determining the necessary components
- Practical assembly of the circuit
- Measuring the travel pressure and travel time for the advance and return strokes
- Calculating the required advance-stroke pressure
- Calculating the advance-stroke speed and time

Exercise

The cover of a hardening furnace is to be raised by a single-acting cylinder. The cylinder is activated by a 3/2-way valve. A 9 kg weight is attached to the cylinder to represent the load. Measure and calculate the following values:

- Travel pressure, load pressure, resistances and back pressure
- Advance-stroke time and speed

Positional sketch

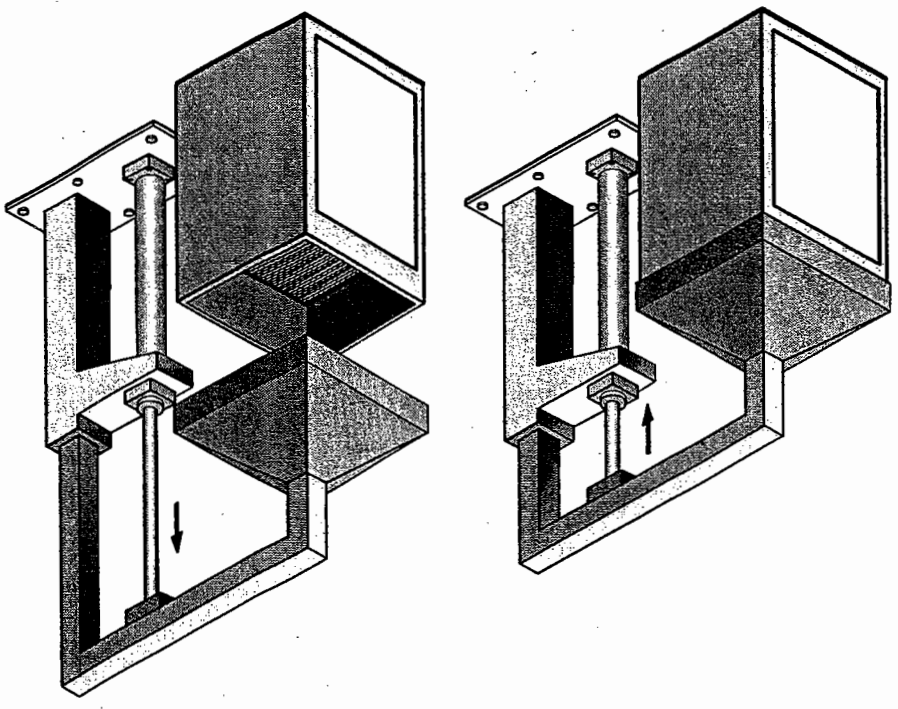



**EXERCISE SHEET**

Characteristic data required for calculation:

- Applied load:  $F_G = 90 \text{ N}$
- Piston area:  $A_{pN} = 2 \text{ cm}^2$
- Stroke length:  $s = 200 \text{ mm}$
- Pump output:  $q = 2 \text{ l/min}$

Load pressure:  $p_L = \frac{F_G}{A_{pN}}$

$p_L =$

Hydraulic resistance = Travel pressure - load pressure

$p_{res} =$

How great is the back pressure in relation to the hydraulic resistance?

Conclusion

Evaluation

Direction	Travel pressure	Travel time
Advance stroke		
Return stroke		

Advance-stroke speed:  $V_{adv} = \frac{A_{PN}}{q}$

$V_{adv} =$

Advance-stroke time:  $t_{adv} = \frac{V_{adv}}{S}$

$t_{adv} =$

Conclusion Do the calculated and measured advance-stroke times agree?

---



---



---

**Furnace door control**

**Hydraulics**

**Subject**

**Title**

**Training aim**

- To familiarise the student with the applications of a 4/2-way valve
- To show how to determine times, pressures and forces during the advance and return strokes of a double-acting cylinder

**Problem definition**

- Drawing the hydraulic circuit diagram
- Determining the necessary components
- Practical assembly of circuit
- Measuring the travel and back pressures and transfer time for the advance and return strokes
- Calculation of advance and return-stroke speeds
- Comparison of calculated and measured values

*Exercise* A furnace door is opened and closed by a double-acting cylinder. The cylinder is activated by a 4/2-way valve with spring return. This ensures that the door opens only as long as the valve is actuated. When the valve actuating lever is released, the door closes again.

*Positional sketch*

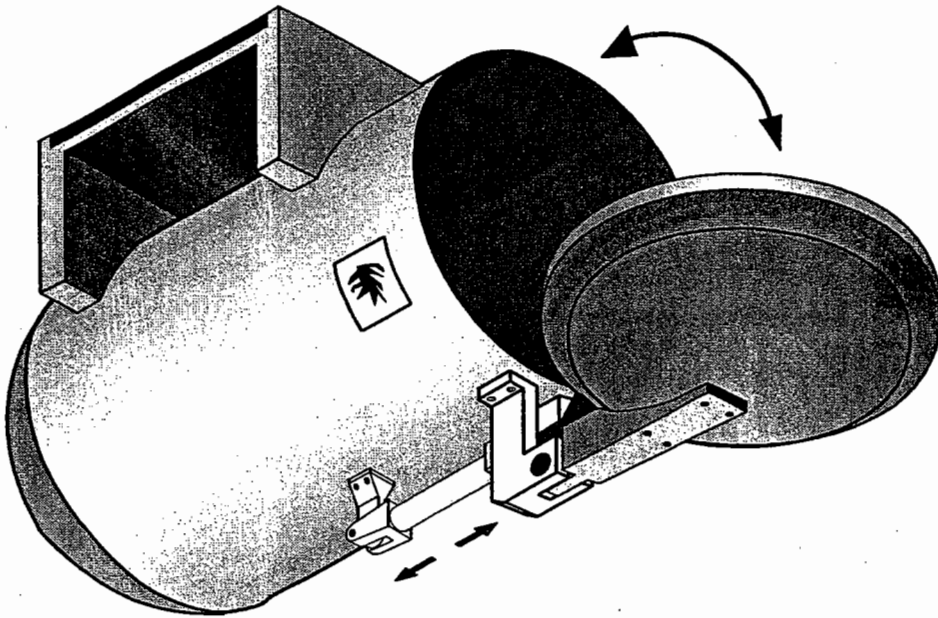

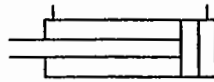
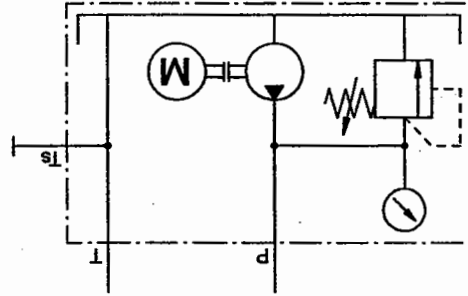



**EXERCISE SHEET**

Circuit diagram, hydraulic

Evaluation

	Return stroke	Back pressure $p_{1s1}$	Travel pressure $p_{1s2}$	Travel time $t_{ret}$
	Advance stroke	Travel pressure $p_{1s1}$	Back pressure $p_{1s2}$	Travel time $t_{adv}$
				

Characteristic data required for calculation:

Piston area:  $A_{PN} = 2.0 \text{ cm}^2$

Piston annular area:  $A_{PR} = 1.2 \text{ cm}^2$

Stroke length:  $s = 200 \text{ mm}$

Pump output:  $q = 2 \text{ l/min}$

Area ratio:

$$\alpha = \frac{A_{PR}}{A_{PN}}$$

$$\alpha =$$

Advance-stroke speed:  $V_{adv} = \frac{A_{PN}}{q}$

$$V_{adv} =$$

Advance-stroke time:

$$t_{adv} = \frac{V_{adv}}{s}$$

$$t_{adv} =$$

Return-stroke speed:

$$V_{ret} = \frac{A_{PR}}{q}$$

$$V_{ret} =$$

---



---



---



---



---



---



---



---



---



---

Compare the advance- and return-stroke speeds and times with the area ratio. What is the relationship between these? *Conclusion*

Ratio of travel times:

$$\frac{t_{adv}}{t_{ret}} =$$

Ratio of travel speeds:

$$\frac{V_{adv}}{V_{ret}} =$$

Return-stroke time:

$$t_{ret} = \frac{V_{ret}}{S}$$

$$t_{ret} =$$

---

---

---

---

---

---

---



Hydraulics

Conveyor tensioning device

Subject  
Title

- Training aim
- To familiarise the student with the applications of a 4/2-way valve
  - To show how to use a piloted non-return valve

- Problem definition
- Drawing the hydraulic circuit diagram
  - Determining the necessary components
  - Practical assembly of the circuit
  - Measuring travel and back pressure and the system pressure in all valve positions
  - Calculating the power balance for circuits with various 4/3-way valves with different mid-positions

Exercise

Parts are fed through a drying oven on a steel chain conveyor belt. It must be possible to correct the tracking of the belt by means of a tensioning device to ensure that the belt does not run off its rollers. This device consists of a steel roller fixed at one end and movable at the other by means of a double-acting cylinder. Hydraulic power must be available continuously. The hydraulic system must switch to the recirculating (pump bypass) condition when the directional control valve is not actuated. The clamping station causes a continuous counter force to act on the cylinder. A piloted non-return valve is used to prevent creepage of the piston rod of the positioning cylinder as a result of oil leakage losses in the directional control valve.

For the purposes of comparison, calculate the required drive power for circuits firstly with a 4/3-way valve, recirculating in mid-position and secondly with a 4/3-way valve, closed in mid-position.

Positional sketch

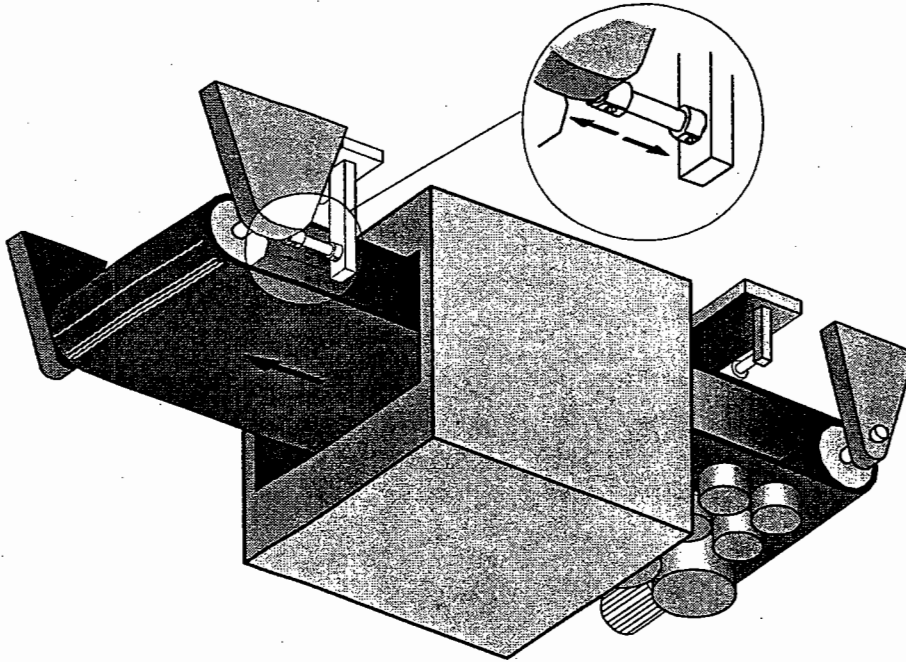

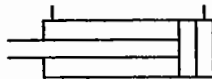
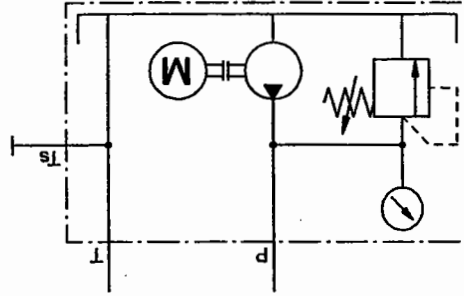



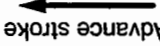

Circuit diagram, hydraulic

**EXERCISE SHEET**

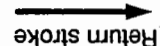
Evaluation

Direction	Valve position	System pressure	Travel and back pressure
Advance stroke 		pozz	psiz
Return stroke 			
Mid-position			

Calculation of drive power::

$$P_{DR} = \frac{p \cdot q}{\eta}$$

Characteristic data required for calculation:

- $P_{DR}$  = Required drive power
- $p$  = System pressure supplied by pump: Maximum 50 bar
- $q$  = Flow rate of pump: Constant 2 l/min
- $\eta$  = Pump efficiency: Approx. 0.7

Drive power with closed mid-position:

$$P_{DR} =$$

Drive power with recirculating mid-position:

$$P_{DR} =$$

Conclusion What is the advantage of a recirculating (bypass) circuit?

---



---



---

Hydraulics

Cold-store door

Subject

Title

- To show the use of a hydraulic accumulator as a power source
- To show how to use the accumulator to power advance and return strokes of the cylinder after the pump is switched off

Training aim

- Drawing the hydraulic circuit diagram
- Determining the necessary components
- Practical assembly of the circuit
- Determining the number of working cycles possible after the pump is switched off
- Drawing conclusions
- Explaining the design and mode of operation of a diaphragm accumulator
- Naming possible applications of an accumulator

Problem definition

Exercise

A heavy cold-store door is opened and closed by a hydraulic cylinder. A hydraulic accumulator is to be installed to allow the door to be closed in the case of an electrical power failure. This will permit the cold-store door to be opened and closed a number of times. A 4/2-way valve is to be used to activate the cylinder. This valve should be connected up in such a way that the piston rod is advanced with the valve in its normal position.

No provision will be made here for the safety cut-out which is essential to prevent persons from becoming trapped in the door. This cut-out function is normally provided by an electrical control device for the hydraulic system.



Be sure to follow the operating instructions for the accumulator. After switching off the control system, do not dismantle the hydraulic components until you have relieved the pressure in the accumulator and isolated this from the control system by means of the built-in shut-off valve. It is essential to relieve the accumulator pressure via a flow control valve!

Positional sketch

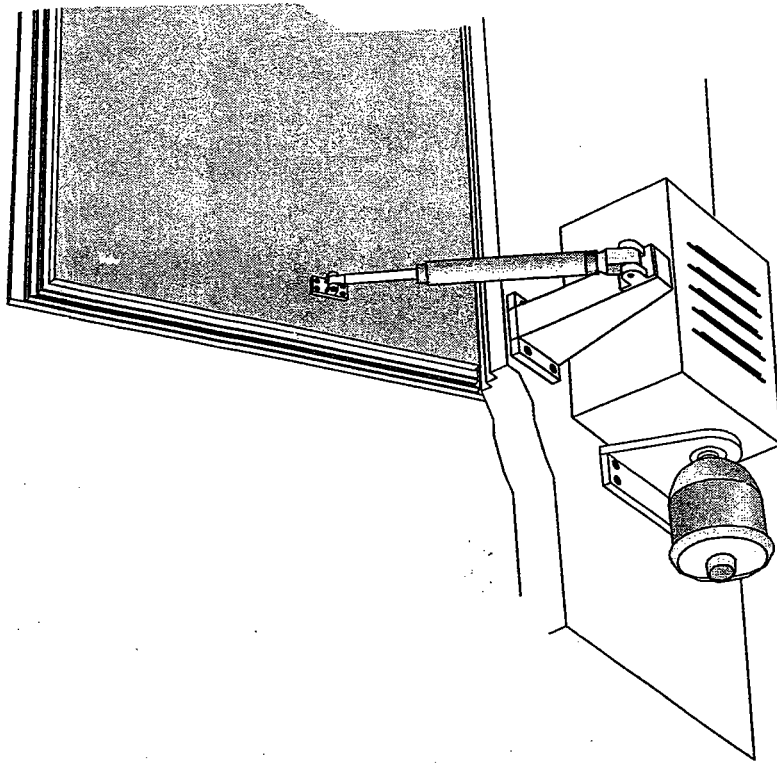

Circuit diagram, hydraulic

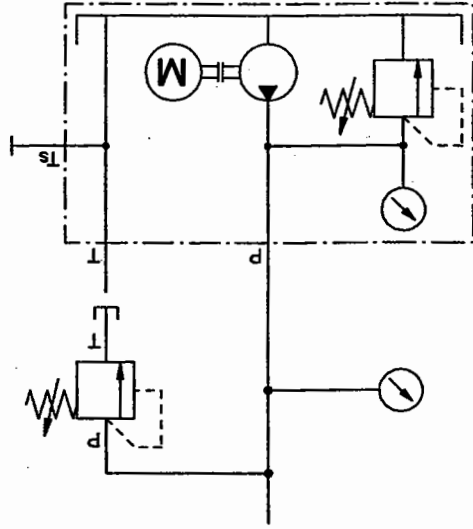
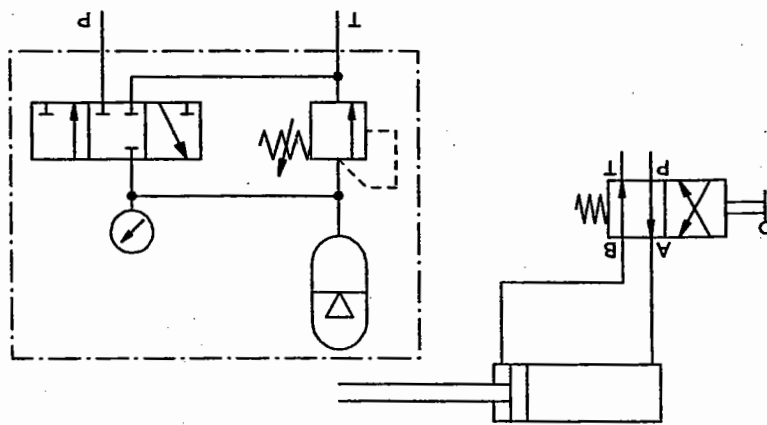

EXERCISE SHEET

Evaluation

System pressure	Opening	Closing
50 bar		
20 bar		

Conclusion What is the effect of fitting an accumulator to this circuit?

---

---

Explain the design and function of a diaphragm accumulator.

---

---

---

---

---

Name examples of applications of accumulators.

---

---

---



Hydraulics

Rotary machining station

Subject

Title

Training aim

- To familiarise the student with the use of a 2-way flow control valve
- To show how to assemble a counter-holding circuit

Problem definition

- Understanding of a hydraulic circuit diagram
- Practical assembly of the circuit
- Commissioning a circuit with a flow control valve and counter-holding
- Adjustment and measurement of inlet and outlet pressures and cylinder travel time
- Comparison of cylinder advance-stroke times for various inlet and outlet pressures

Several stations on a rotary machining station are driven by a hydraulic power pack.

As individual stations are switched on and off, they produce pressure fluctuations throughout the hydraulic circuit. This effect will be studied on a drilling station. The fluctuations in pressure and the tractive forces created during drilling must not affect the feed of the drilling station. A flow control valve is to be used to ensure a smooth adjustable feed rate, while a pressure relief valve is to be used as a counter-holding valve to compensate for the tractive forces.

Positional sketch

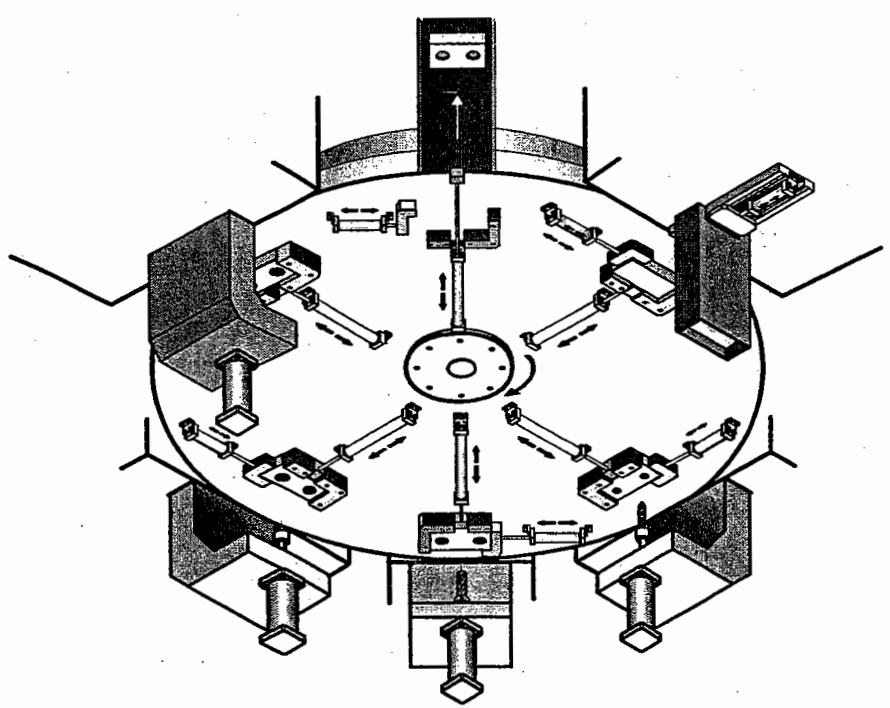

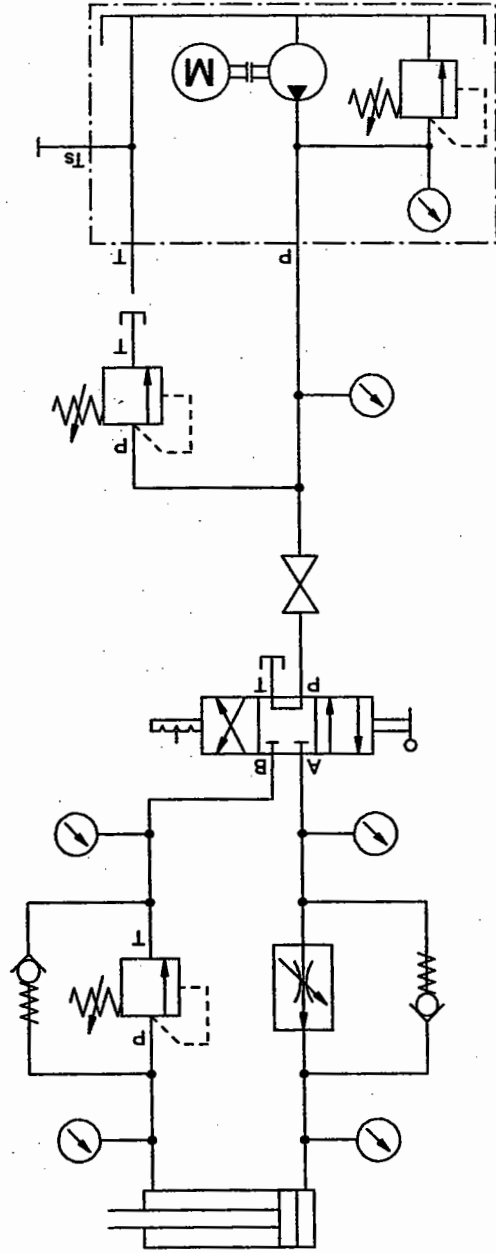

Circuit diagram, hydraulic

EXERCISE SHEET

Evaluation

Measure the following:

$p_{1z1}$  = Pressure upstream of flow control valve

$p_{1z3}$  = Pressure downstream of flow control valve

$p_{1z4}$  = Pressure at counter-holding valve

$t \rightarrow$  = Advance-stroke time of cylinder

Fluctuating inlet pressure

$p_{1z1}$	50 bar		10 bar
	40 bar		10 bar
	30 bar		10 bar
	20 bar		10 bar
	10 bar		10 bar
$p_{1z3}$			
$p_{1z4}$			
$t \rightarrow$			

Fluctuating outlet pressure

$p_{1z1}$	50 bar		50 bar
	50 bar		50 bar
	50 bar		50 bar
	20 bar		50 bar
	10 bar		50 bar
$p_{1z3}$			
$p_{1z4}$			
$t \rightarrow$			

Conclusion How does the travel change as the pressures at the inlet and outlet vary?

---



---



---

**Painting booth**

**Hydraulics**

- To show how to plot a characteristic for a 2-way flow control valve
- To show how to make a comparison between a 2-way flow control valve and a throttle-type flow control valve

- Drawing the hydraulic circuit diagram

- Practical assembly of the circuit

- Measurement of pressure and flow rate

- Plotting the characteristic of the 2-way flow control valve

- Comparison with a throttle valve

**Subject**

**Title**

**Training aim**

**Problem definition**

Exercise

An endless chain conveyor feeds workpieces through a painting booth. The chain is driven by a hydraulic motor via a right-angle gear unit. Due to changes in the production process, the weight of the workpieces passing through the painting booth has changed. The speed of the conveyor should, however, remain the same as before. It must be determined whether this can be achieved by fitting a flow control valve, and if so which type is suitable.

Positional sketch

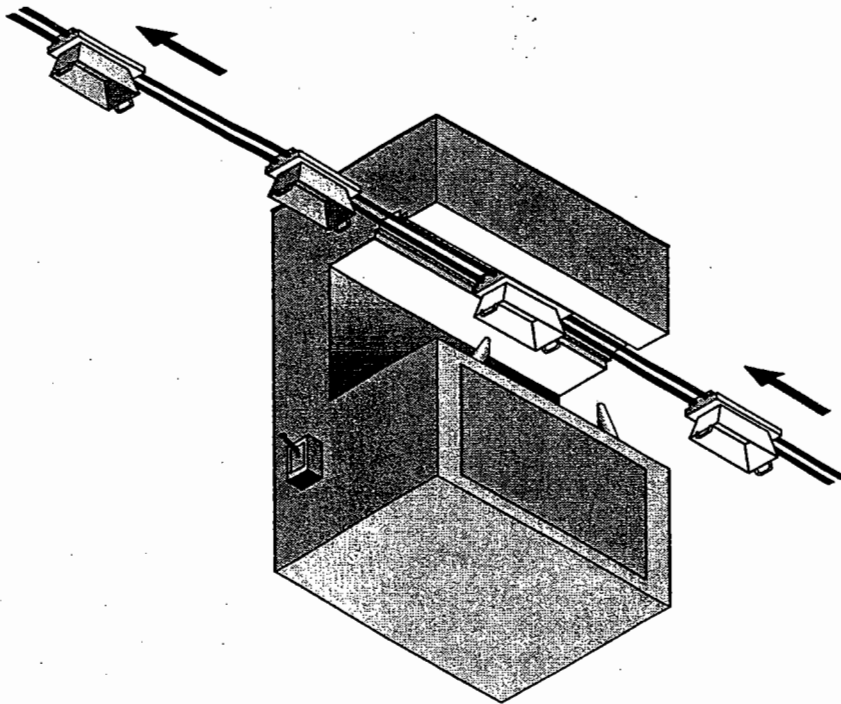

**EXERCISE SHEET**

Measure the following:

$p_{1z1}$  = Pressure upstream of valve

$p_{1z2}$  = Pressure downstream of valve

$q_{TWFCV}$  = Flow rate through 2-way flow control valve

$q_{TV}$  = Flow rate through throttle valve

Fluctuating inlet pressure		Fluctuating load pressure	
$p_{1z1}$	$p_{1z2}$	$p_{1z1}$	$p_{1z2}$
50 bar	10 bar	50 bar	10 bar
40 bar	10 bar	50 bar	20 bar
30 bar	10 bar	50 bar	30 bar
20 bar	10 bar	50 bar	40 bar
10 bar	10 bar	50 bar	50 bar
$q_{SRV}$	2 l/min	$q_{SRV}$	2 l/min
$q_{AV}$	2 l/min	$q_{AV}$	2 l/min

Evaluation

Flow control valve characteristic

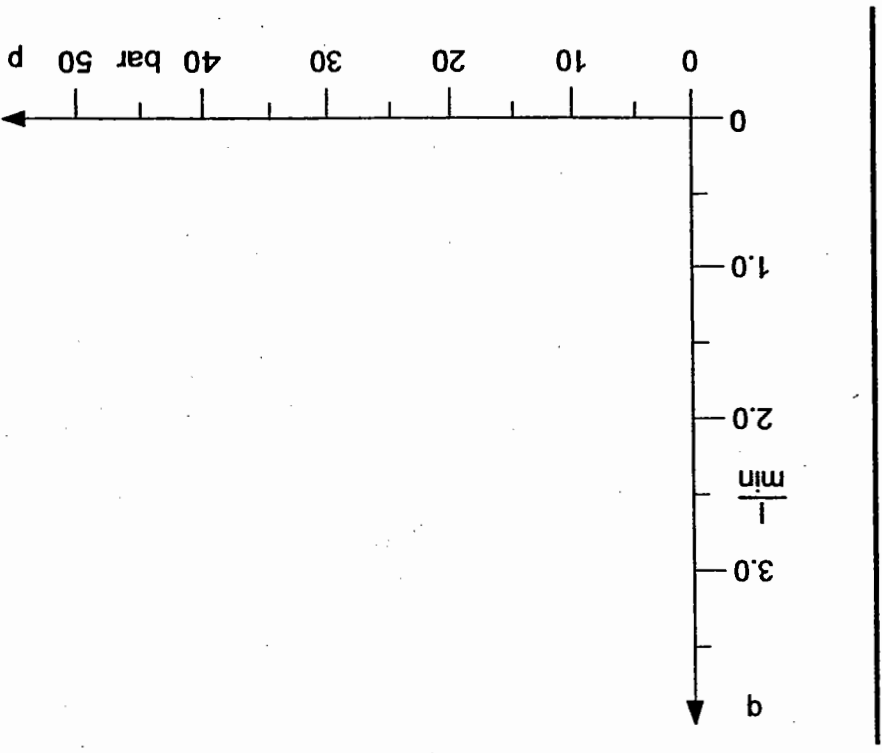

Conclusion Which valve is suitable for this application and why?

---

---

---

---



- Drawing the hydraulic circuit diagram
- Practical assembly of the circuit
- Commissioning a circuit with a one-way flow control valve and counter-holding
- Adjustment and measurement of inlet and outlet pressures and cylinder advance-stroke time
- Comparison of advance-stroke times with those in exercise 9

*Problem definition*

- To familiarise the student with the use of a one-way flow control valve
- To show how to explain the difference between a flow control valve and throttle valve on the basis of a concrete application

*Training aim*

**Embossing machine**

Hydraulics

Subject

Title

Exercise

A special machine is used to emboss graphic symbols on metal foil. The foil is fed through the embossing machine with an adjustable cycle time. The downward motion of the stamp must be capable of being varied in accordance with the feed speed. The return motion must always be executed as a rapid traverse.

A one-way flow control valve is used to control the speed of the stamp, while a pressure relief valve is used to prevent the weight of the stamp from pulling the piston rod out of the cylinder. A 4/2-way valve is used to switch between upwards and downwards motion.

Positional sketch

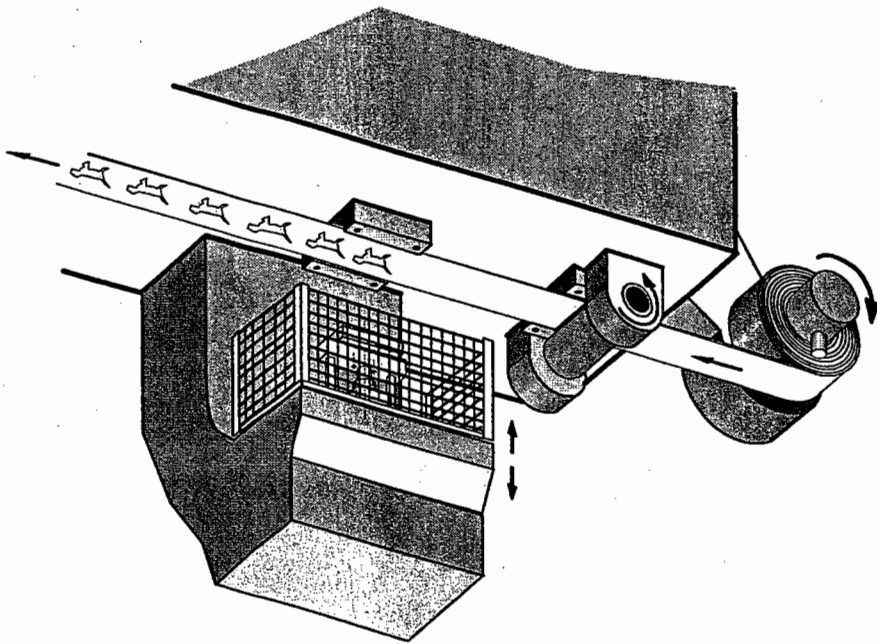

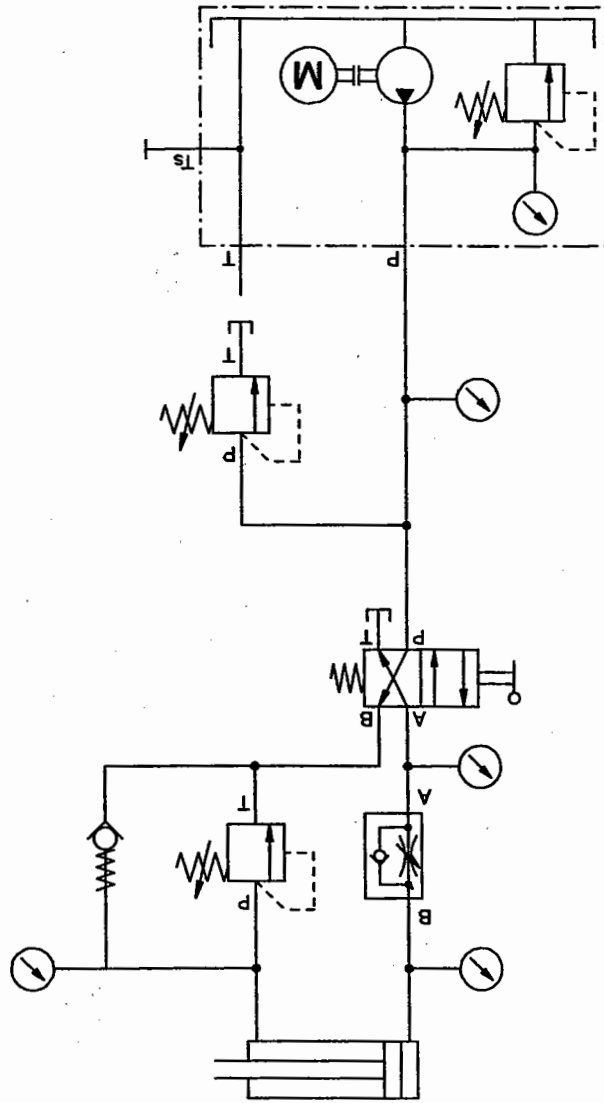

Circuit diagram, hydraulic

EXERCISE SHEET

Evaluation

Measure the following:

- $p_{1z1}$  = Pressure upstream of one-way flow control valve
- $p_{1z3}$  = Pressure downstream of one-way flow control valve
- $p_{1z4}$  = Pressure at counter-holding valve
- $t \rightarrow$  = Cylinder advance-stroke time

Fluctuating inlet pressure

$p_{1z1}$	50 bar		10 bar
	40 bar		20 bar
	30 bar		30 bar
	10 bar		40 bar
	10 bar		50 bar
$p_{1z4}$		$p_{1z3}$	
$t \rightarrow$			

Fluctuating outlet pressure

$p_{1z1}$	50 bar		50 bar
	50 bar		50 bar
	50 bar		50 bar
	20 bar		50 bar
	10 bar		50 bar
$p_{1z4}$		$p_{1z3}$	
$t \rightarrow$			

Conclusion

How does the travel time change as the pressures at the inlet and outlet vary?

What is the difference between this circuit and the one with the 2-way flow control valve (see exercise 9) and what is the reason for this?

- Understanding a hydraulic circuit diagram
  - Practical assembly of the circuit
  - Measuring advance and return stroke times and travel and back pressures
  - Calculation of ratios for area and force
  - Calculation of the flow rate through the flow control valve
  - Comparison of this circuit with the one in exercise 6
- Problem definition*

- To familiarise the student with the design and mode of operation of a differential circuit
  - To show how to explain the influence of pressures, forces, speeds and travel times
- Training aim*

*Hydraulics*  
**Surface grinding machine**  
*Title*  
**Subject**

Exercise

The grinding table of a surface grinding machine is driven by a hydraulic cylinder. Since the speed is required to be the same in both directions, the hydraulic control circuit must be designed to provide compensation for the difference in volume of the two cylinder chambers. A differential circuit is suggested with a 3/2-way valve and a flow control valve for speed adjustment.

Positional sketch

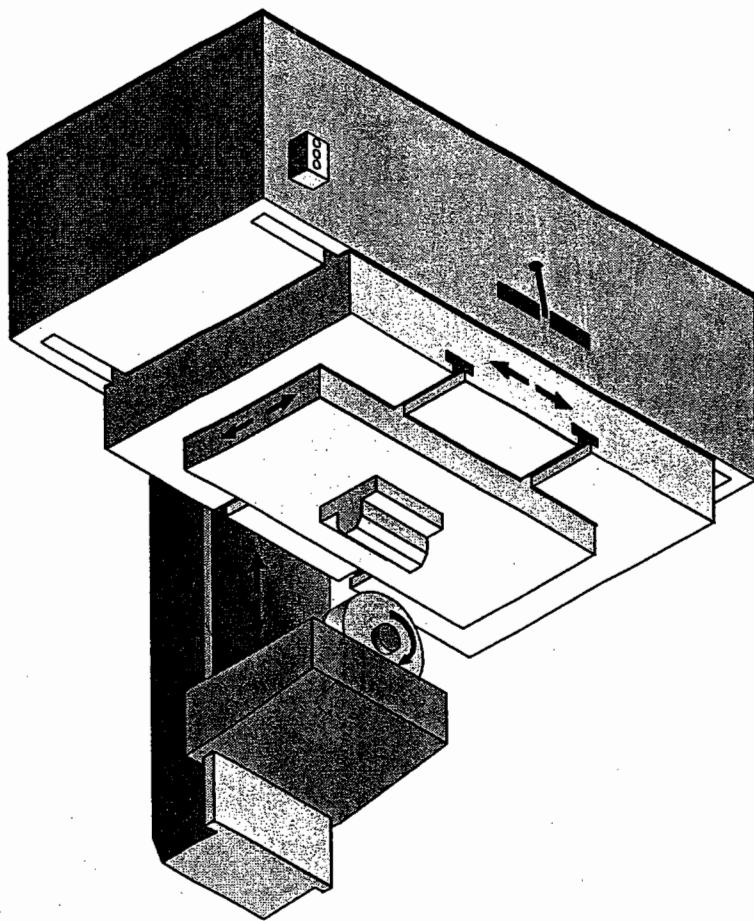

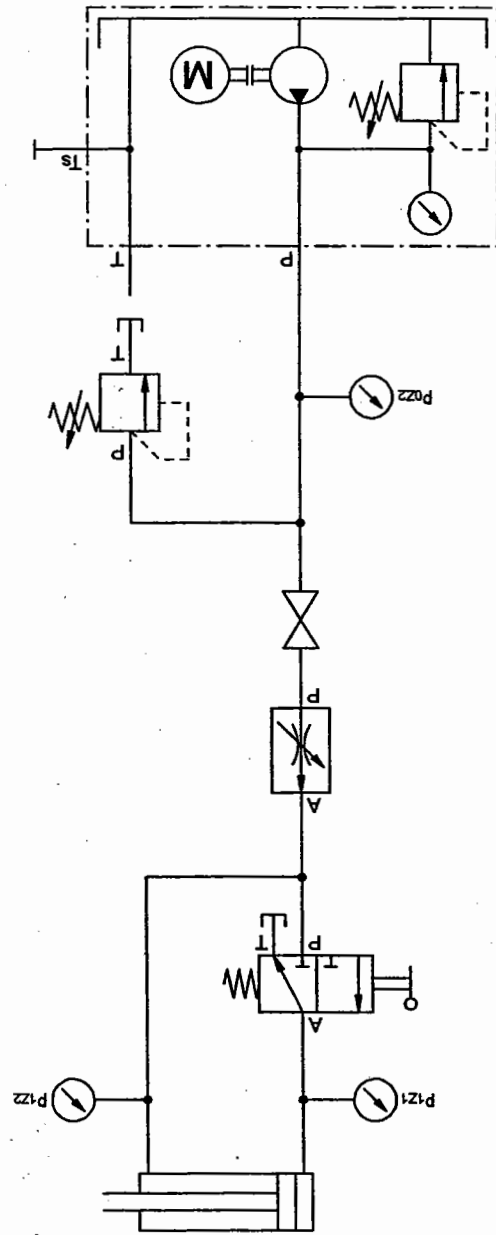

Circuit diagram, hydraulic

EXERCISE SHEET

Evaluation

Measure the following:

$p_{1z1}$  = Pressure on piston side of cylinder

$p_{1z2}$  = Pressure on annular side of cylinder

$p_{0z2}$  = System pressure = 50 bar

$t \rightarrow$  = Cylinder advance-stroke time approx. 4 s

Direction	$p_{1z1}$	$p_{1z2}$	$t$
Advance stroke			
Return stroke			

Values table

Cylinder dimensions:

Piston area:  $A_{PN} = 2.0 \text{ cm}^2$

Piston annular area:  $A_{PR} = 1.2 \text{ cm}^2$

Cylinder stroke:  $s = 0.2 \text{ m}$

Area ratio:

$$\alpha = \frac{A_{PN}}{A_{PR}} =$$

Time ratio:

$$\frac{t_{adv}}{t_{ret}} =$$

Force ratio:

$$\frac{F_1}{F_2} = \frac{A_{PN} \cdot p_{1z1}}{A_{PR} \cdot p_{1z2}} =$$

Flow rate during advance stroke:

Piston side:

$$q_{PN} = A_{PN} \cdot \frac{t_{adv}}{s} =$$

Piston annular side:

$$q_{PR} = A_{PR} \cdot \frac{t_{adv}}{s} =$$



---



---

What force can the cylinder exert during its advance stroke?

---



---

During the advance stroke, the pressures in the two cylinder chambers are different. Why does the piston advance despite the fact that the travel pressure is lower than the back pressure?

---



---

When the 3/2-way valve is activated, the same pressure is present at both cylinder ports. Why does the piston advance?

*Conclusion*

Piston annular side:  $q_{PR} = A_{PR} \cdot \frac{t_{rel}}{s} =$

Flow rate during return stroke:

$q_{FCV} = q_{PN} - q_{PR} =$

Flow control valve component:

**EXERCISE SHEET**

What is the difference between this differential circuit and a simple cylinder control circuit (one connection to each of P and T as, for example, in exercise 6)?

1. What are the factors governing the advance-stroke speed  $v_{adv}$ ?
2. What is the value of the return-stroke speed  $v_{ret}$  in comparison with the advance-stroke speed  $v_{adv}$ ?
3. What are the factors governing the advance-stroke time  $t_{adv}$ ?
4. What is the value of the return-stroke time  $t_{ret}$  in comparison with the advance-stroke time  $t_{adv}$ ?

System		Simple cylinder control circuit		Differential circuit	
1. Advance-stroke speed $v_{adv}$					
2. Return-stroke speed $v_{ret}$					
3. Advance-stroke time $t_{adv}$					
4. Return-stroke time $t_{ret}$					

Vergleich

What area ratio results in identical advance and return stroke speeds (using a differential circuit)?

Conclusion

---



---



---



---

Subject

Title

**Drilling machine**

Hydraulics

- Training aim**
- To teach the student how to design a control circuit with reduced out-put pressure
  - To show how to explain the mode of operation of a 3-way pressure regulator

**Problem definition**

- Drawing the hydraulic circuit diagram
- Practical assembly of the circuit
- Measuring the travel and back pressures
- Setting a counter pressure
- Assessment of the effect of using a pressure regulator

*Exercise* A drilling machine is used for work on various hollow workpieces. The workpieces are hydraulically clamped in a vice. It must be possible to reduce the clamping pressure to suit the design of the workpiece. It must also be possible to vary the closing speed by means of a one-way flow control valve.

*Positional sketch*

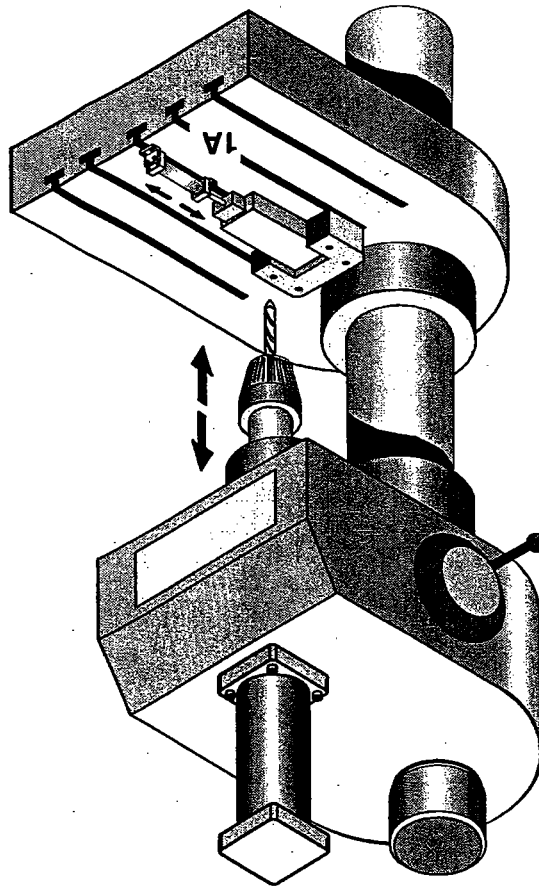

**EXERCISE SHEET**

Measure the following:  
 $p_{1z1}$  = Pressure upstream of flow control valve  
 $p_{1z2}$  = Pressure upstream of cylinder  
 $p_{1z3}$  = Pressure downstream of cylinder

Study the following cases:

1. Piston advance stroke
2. Piston advanced to end position with setting  $p_{1z2} = 15 \text{ bar}$ .
3. Piston advance stroke with counter pressure setting,  $p_{1z3} = 20 \text{ bar}$ .
4. Piston advanced to end position
5. Piston advance stroke with shut-off valve closed
6. Piston advanced to end position with shut-off valve closed

Evaluation

Cases of examination			$p_{1z1}$	$p_{1z2}$	$p_{1z3}$
1. Advance stroke					
2. End position					
3. Advance stroke with counter pressure					
4. End position					
5. Advance stroke with pressure regulator					
6. End position					

Advance stroke

Cases of examination			$p_{1z1}$	$p_{1z2}$	$p_{1z3}$
1. Return stroke					
2. End position					
3. Return stroke with counter pressure					
4. End position					
5. Return stroke with pressure regulator					
6. End position					

Return stroke

*Conclusion* When is it appropriate to use a pressure regulator?

What possible disadvantage may result from the use of a pressure regulator?

---

---

---

---

---

---

**Bulkhead door**

**Hydraulics**

**Subject**  
**Title**

- To familiarise the student with a circuit for the hydraulic clamping of a bulkhead door
- To demonstrate a comparison of circuits with and without counter-holding

**Problem definition**

- Drawing the hydraulic circuit diagram
- Practical assembly of the circuit
- Measuring the cylinder advance-stroke time with and without a load and with and without counter-holding
- Comparison and assessment of results

Exercise

A double-acting cylinder is used to open and close a bulkhead door. Closing must be carried out smoothly and at a constant adjustable speed. The speed is adjusted by means of a one-way flow control valve. A pressure relief valve must be fitted to provide counter-holding and prevent the heavy door from pulling the piston rod out of the cylinder during the closing operation.

Positional sketch

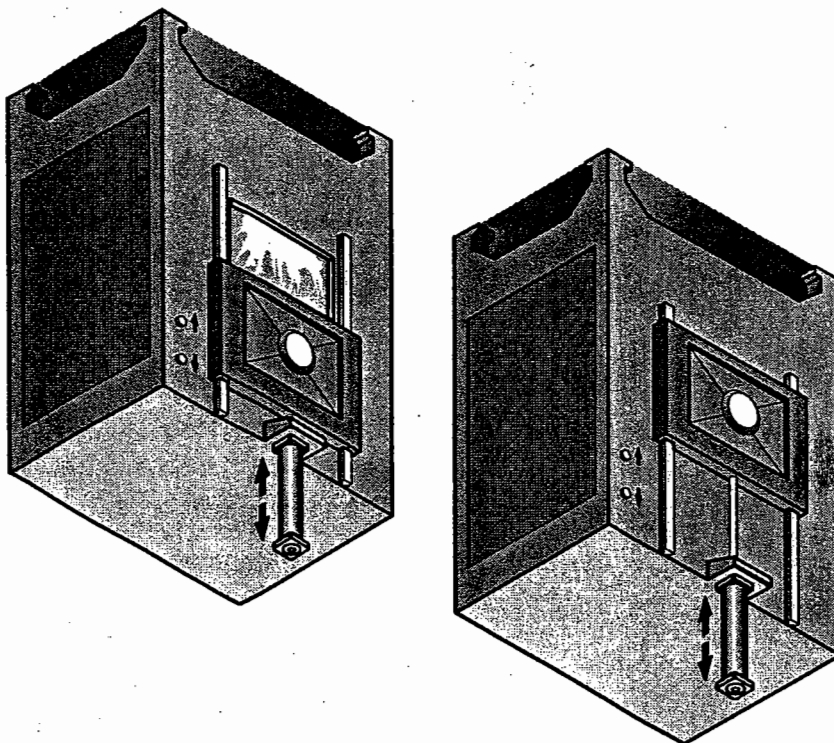



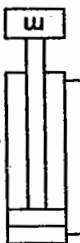
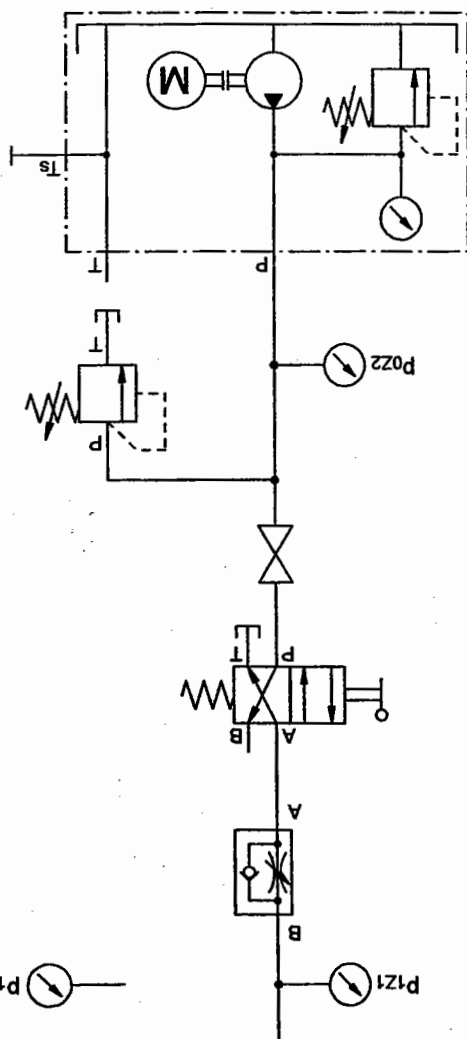

Circuit diagram, hydraulic

EXERCISE SHEET

Evaluation

Measure the following:

$t \rightarrow$  = Cylinder advance-stroke time

$p_{z1}$  = Cylinder travel pressure

$p_{z2}$  = Cylinder back pressure

$p_{0z2}$  = System pressure

The applied load and counter-holding should now be varied. Initial settings should be such as to achieve an advance-stroke time of 5 s with a system pressure of 50 bar but without an applied load or counterholding. 10 bar back pressure should subsequently be set.



When dismantling the circuit, ensure that no pressurised fluid is trapped ( $p_{z2} = 0 \text{ bar}$ ).

Values table

Load and counter-holding	$p_{0z2}$	$p_{z1}$	$p_{z2}$	$t \rightarrow$
Without load or counter-holding	50 bar			5 s
With load without counter-holding				
With load and counter-holding				
Without load with counter-holding				

Conclusion

How does the travel time vary as the load changes?

Which circuit is more suitable?

---



---



---



---

Hydraulics

Ferry loading ramp

Subject

Title

- To familiarise the student with a speed control circuit with a tractive load
- To compare circuits with flow control valves in the inlet line and outlet line respectively
- Drawing the hydraulic circuit diagram
- Practical assembly of the circuit
- Measuring the cylinder advance time and travel and back pressures with flow control valves in the inlet line and outlet line respectively
- Comparison and assessment of results

Training aim

Problem definition

Exercise

The loading ramp of a car ferry must be capable of being set to different heights. The ramp is raised and lowered by a hydraulic cylinder. This motion must be carried out smoothly and at a constant speed. A flow control valve is to be used to adjust the speed. This must be installed in such a way as to prevent excessive pressures from developing within the system.

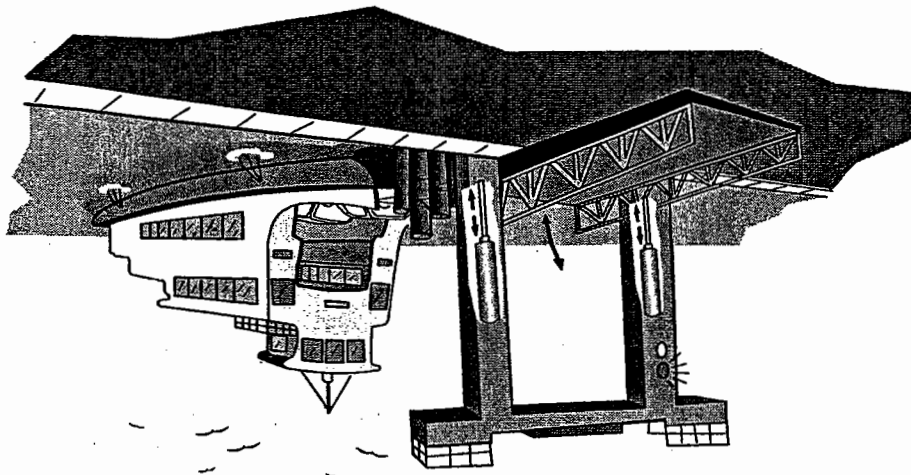

Positional sketch

Circuit diagram, hydraulic

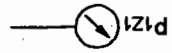
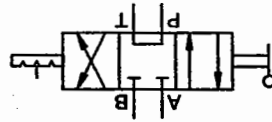
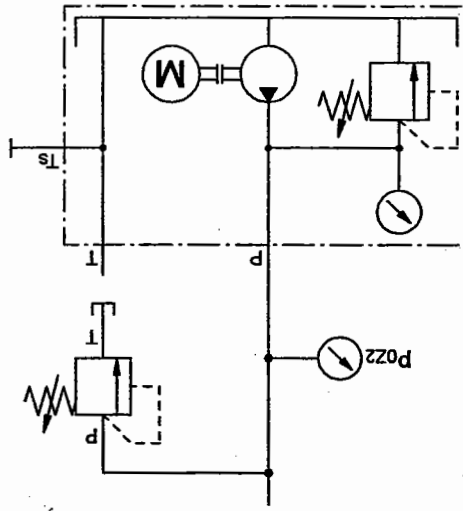

EXERCISE SHEET

Evaluation Measure the following:

- $t \rightarrow$  = Cylinder advance-stroke time
- $p_{1z1}$  = Cylinder travel pressure
- $p_{1z2}$  = Cylinder back pressure
- $p_{0z2}$  = System pressure

Vary the following:

- Applied load
- Counter-holding
- Flow control in inlet and outlet lines

Settings:

- First, without an applied load or counter-holding and with a flow control valve in the inlet line, make settings to obtain an advance-stroke time of  $t \rightarrow = 5$  s with a system pressure of  $p_{0z2} = 50$  bar.
- Then set a counter pressure of  $p_{1z2} = 10$  bar.
- Then use a flow control valve in the outlet line to provide counter-holding.



When dismantling the circuit, ensure that no pressurised fluid is trapped ( $p_{1z2} = 0$  bar).

Which circuit is more suitable?

---



---



---



---



---

How does the travel time change as the load is varied?

Conclusion

Flow control valve in inlet line	Load and counter-holding	Without load or counter-holding	With load without counter-holding	With load and counter-holding	Without load with counter-holding
t →	p <sub>02z</sub>	50 bar			
5 s					
	p <sub>1z1</sub>				
	p <sub>1z2</sub>		10 bar		
			10 bar		

Flow control valve in outlet line	Load	Without load	With load
t →	p <sub>02z</sub>	50 bar	
5 s			
	p <sub>1z1</sub>		
	p <sub>1z2</sub>		

**EXERCISE SHEET**





Hydraulics

Skip handling

- To develop a hydraulic circuit for a double-acting cylinder subject to a varying load

Problem definition

- Drawing the circuit diagram
- Practical assembly of the circuit
- Commissioning of control circuit
- Description of mode of operation of control circuit

Subject

Title

Training aim

Exercise

The loading and unloading of skips from a skip transporter is carried out using two double-acting cylinders. Each cylinder is subject to varying loads – tractive load during unloading and compressive load during loading. The skip should be raised and lowered at a slow constant speed. Each cylinder must therefore be hydraulically clamped on both sides.

Positional sketch

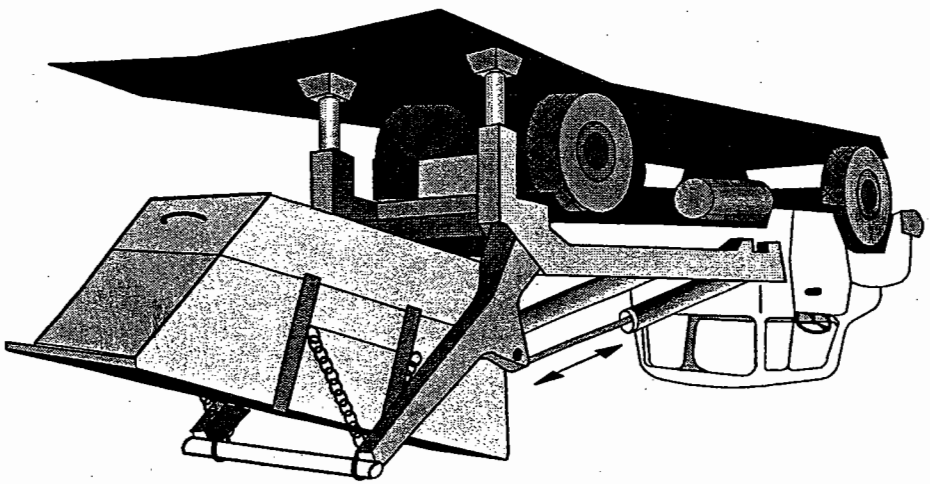

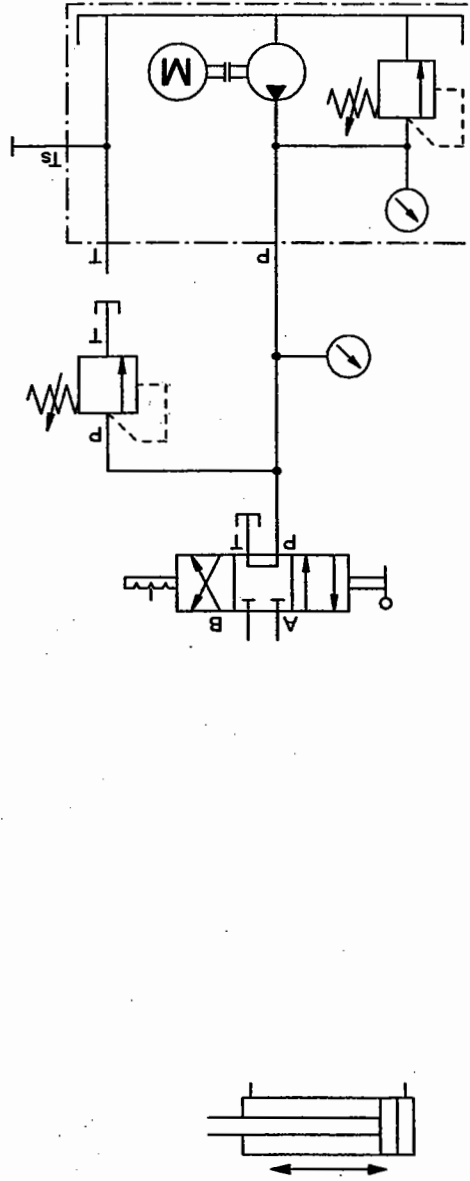

Circuit diagram, hydraulic

EXERCISE SHEET

*Conclusion* How is hydraulic clamping produced on both sides?

---

---

---

---

---

Hydraulics

Bonding press

Subject

Title

- To teach the student how to specify the pressure for a double-acting cylinder
- To show how to choose either a pressure relief valve or a pressure regulator

Training aim

- Drawing the hydraulic circuit diagram
- Practical assembly of the circuit
- Measurement and comparison of system pressure, travel pressure and final pressure
- Assessment of the suitability of a pressure relief valve and pressure regulator

Problem definition

Exercise A bonding press is used to stick pictures or lettering onto wood or plastic panels. The working pressure must be adjustable to suit the base material and adhesive used and must be capable of being maintained for a long time while the directional control valve is activated. Develop and compare two circuits. The first should use a 3-way pressure regulator to adjust the press pressure, while the second should incorporate a pressure relief valve connected into the bypass line for this purpose. A 4/3-way valve should be used for activation in both cases.

Positional sketch

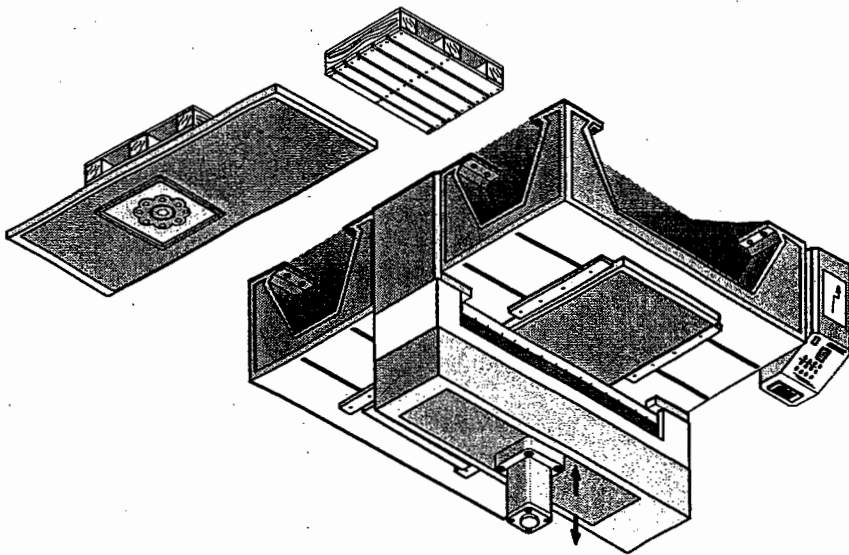

EXERCISE SHEET

Circuit diagram, hydraulic

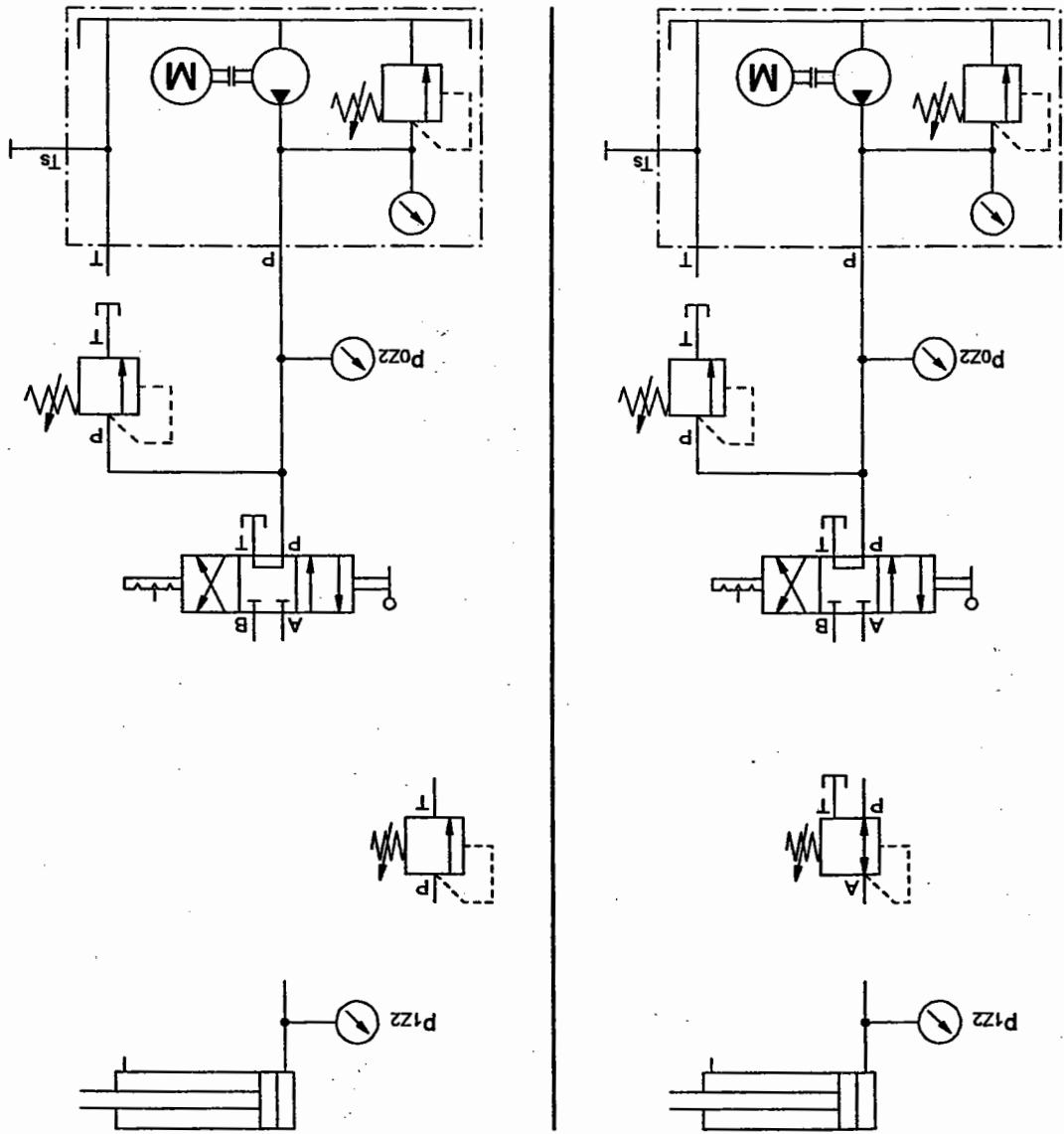

*Evaluation*

Carry out the following settings:

$p_{022}$  = System pressure = 50 bar  
 $p_{122}$  = Pressure upstream of cylinder = 30 bar

*Conclusion*

With which circuit does the system pressure vary as the cylinder advances?

When is it advantageous to use the pressure relief valve?

---

---

---

---

---

---

---

---



Hydraulics

Assembly device

- To familiarise the student with a pressure sequence circuit
- To teach the student how to draw a displacement-step diagram
- Development of hydraulic circuit diagram
- Drawing the displacement-step diagram
- Practical assembly of the circuit
- Systematic commissioning with setting of pressure and flow rate

Subject

Title

Training aim

Problem definition

Exercise

An assembly device is used to press workpieces together for drilling. Cylinder 1A1 presses a workpiece into the housing. This operation should be carried out slowly at a constant speed. When the pressure in cylinder 1A1 has reached 20 bar (workpiece pressed into place), a hole is drilled through the workpiece and housing. The drill is driven by a hydraulic motor. After the drilling operation, the drill is switched off and retracted (1A2). Cylinder 1A1 is retracted only when the drill has withdrawn from the housing.

Positional sketch

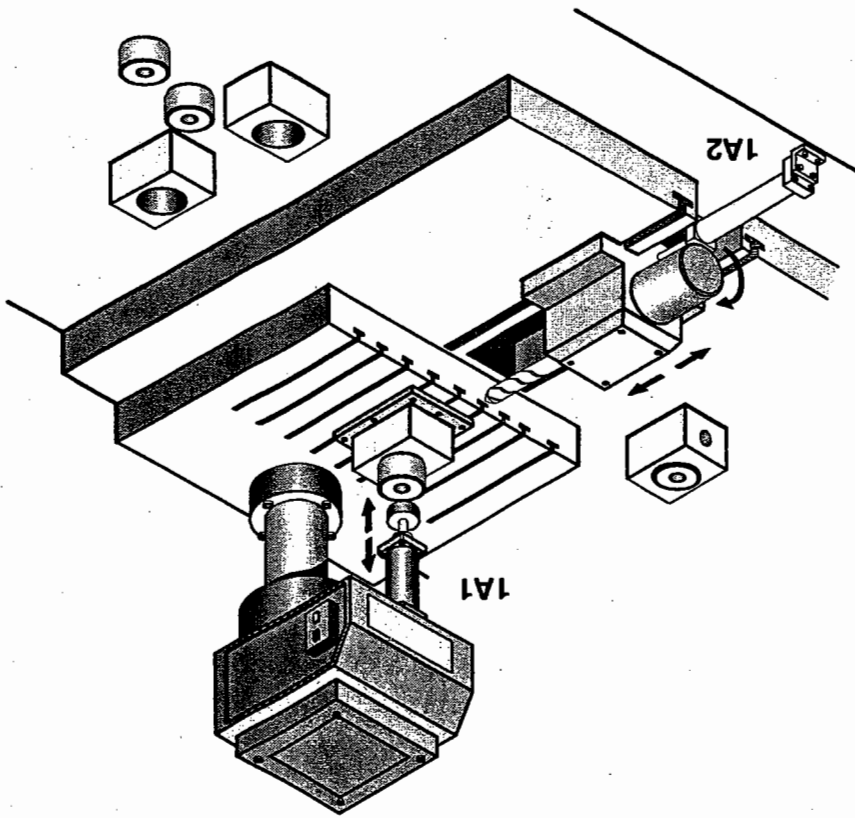

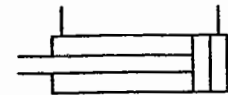
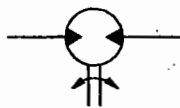
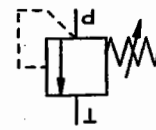
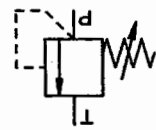
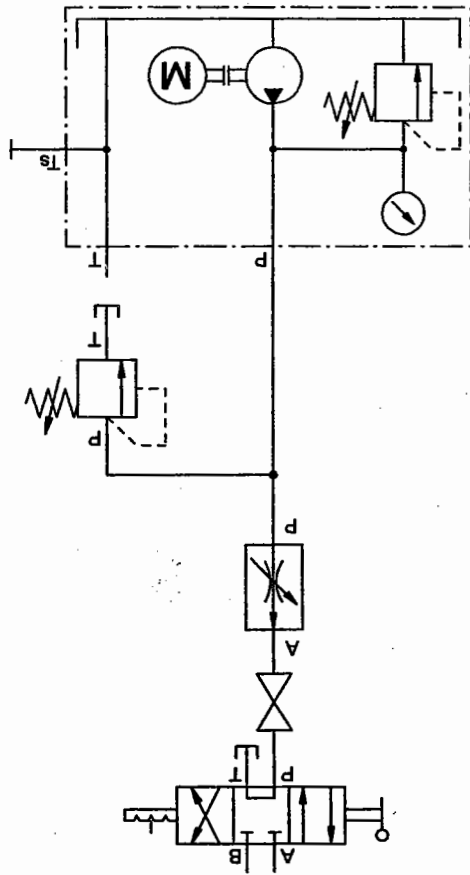

Circuit diagram, hydraulic

EXERCISE SHEET

Displacement-step diagram

Time	Components	
	Description	Designation
Step 1		
2		
3		
4		
5		
6		

Conclusion What are the points to note when commissioning the control circuit?

1. \_\_\_\_\_
2. \_\_\_\_\_
3. \_\_\_\_\_
4. \_\_\_\_\_
5. \_\_\_\_\_
6. \_\_\_\_\_

**Calculations for an assembly device**

**Hydraulics**

**Subject**

**Title**

- To enable the student to calculate the forces associated with a double-acting cylinder
- To enable the student to calculate the advance-stroke time of a cylinder piston

**Training aim**

- Writing a problem description
- Calculating the press-fitting force
- Calculating the press-fitting time

**Problem definition**

Exercise

An assembly device is used to press workpieces together for drilling. The operating sequence is described in exercise 18. Our objective here is to check the pressing operation of cylinder 1A1 mathematically. Determine the press-fitting force using the given data. Note that, while the press-fitting pressure is available as specified, the resistances of the lines and directional control valve cause an opposing pressure to act on the annular piston side, thus reducing the actual force available. The flow rate is kept constant by a flow control valve. This together with the cylinder stroke is used to calculate the travel time for the press-fitting operation.

Positional sketch

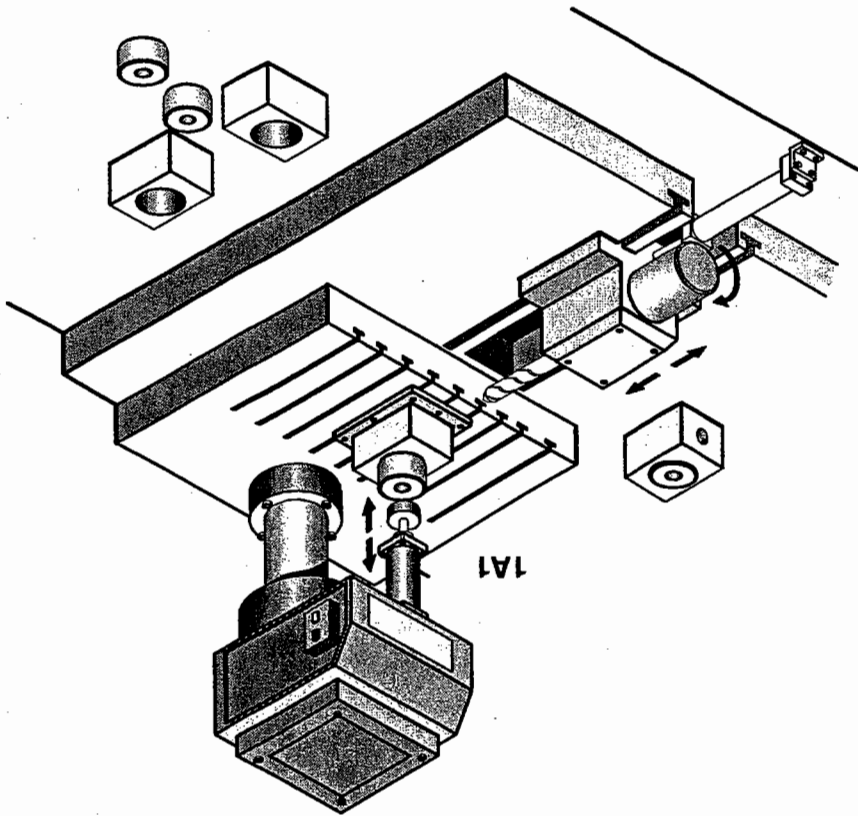

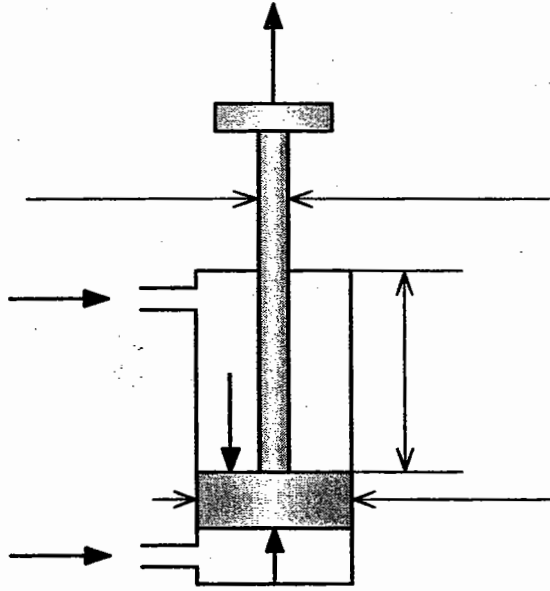

Schematic diagram

Hydraulic system:  
 Flow rate  
 Press-fitting pressure  
 Counter pressure

$q = 5 \text{ l/min}$   
 $p_1 = 50 \text{ bar}$   
 $p_2 = 6 \text{ bar}$

Cylinder:  
 Piston diameter  
 Piston rod diameter  
 Stroke

$D = 50 \text{ mm}$   
 $d = 25 \text{ mm}$   
 $s = 250 \text{ mm}$

Characteristic data of control system:

Evaluation

**EXERCISE SHEET**

$$F_1 = A_{pN} \cdot p_1 =$$

Piston force:

$$F_2 = A_{pR} \cdot p_2 =$$

Counter force:

$$F = F_1 - F_2 =$$

Press-fitting force:

$$t = \frac{V}{q} =$$

Press-fitting time:



**Tipping container**

**Hydraulics**

- To familiarise the student with an electrohydraulic circuit
- Development of hydraulic and electrical circuit diagrams
- Assembly of control system

**Training aim**

**Problem definition**

**Subject**

**Title**

Exercise

A conveyor belt transports metal swarf into a tipping container. When the container is full, it is emptied into a truck. A double-acting cylinder is used for this purpose, actuated by a solenoid-actuated 4/3-way valve. The piston rod of the cylinder is advanced while the container is in position to receive swarf. To enable the hydraulic power pack to be switched off during this time, the piston rod of the cylinder must be protected by hydraulic means against undesired retraction (caused by leakage in the valve). The electrical activation of the valve must be manually controlled, i.e. the cylinder must move only when the "Up" or "Down" pushbuttons are pressed.

Positional sketch

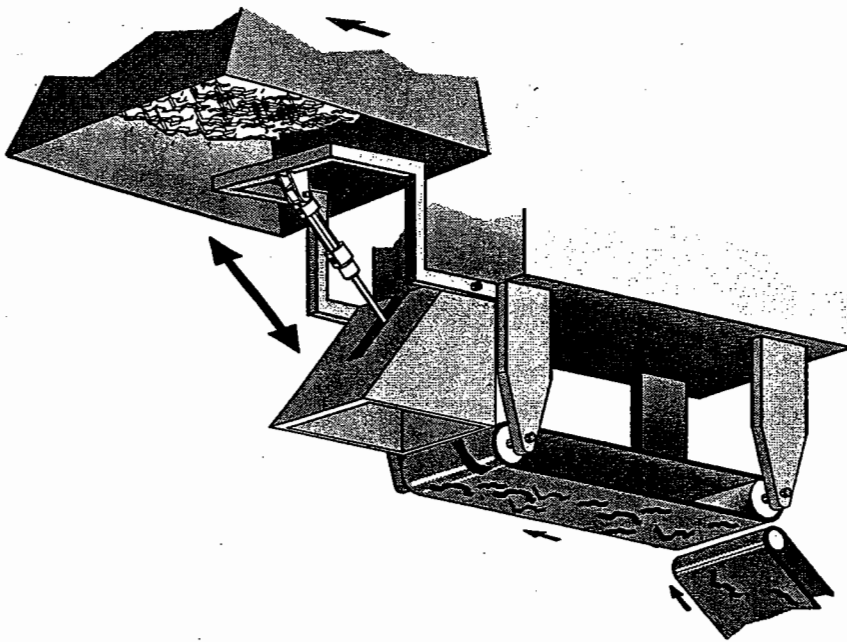

**EXERCISE SHEET**

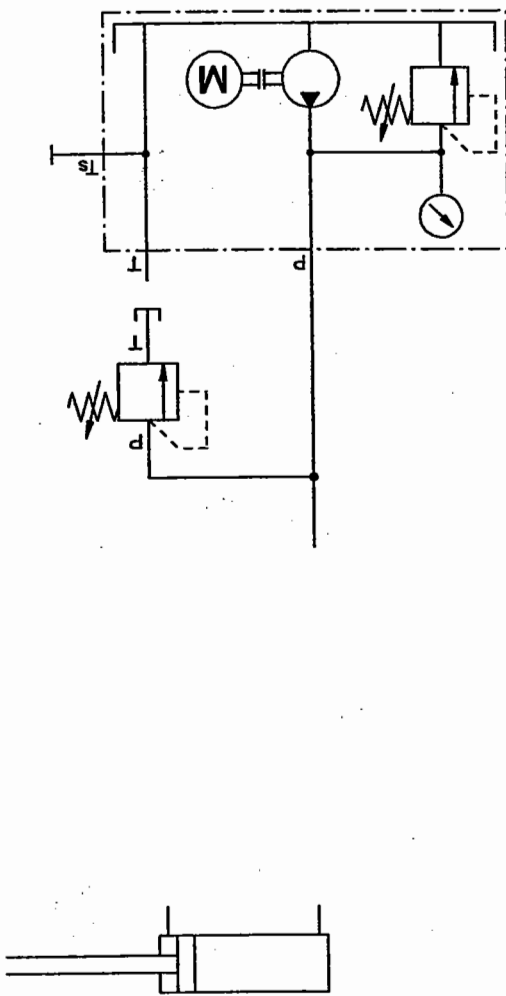

Circuit diagram, hydraulic

Circuit diagram, electrical

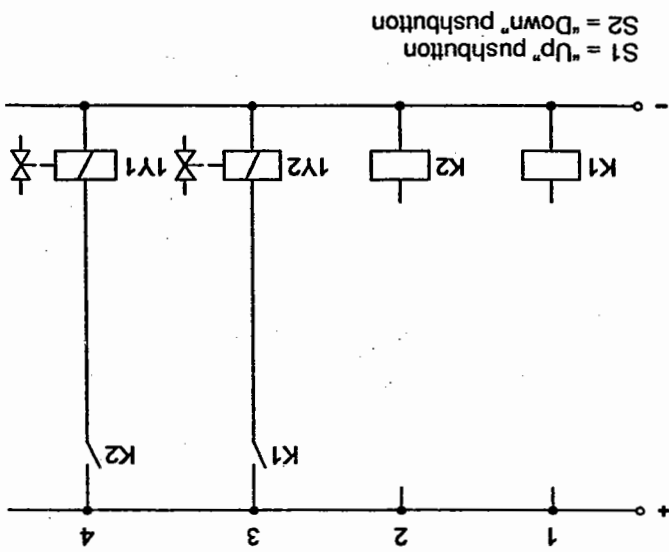

Conclusion  
What measure ensures that the cylinder maintains its position and does not move even if the "Up" and "Down" pushbuttons are accidentally pressed simultaneously?

---

---

---

---

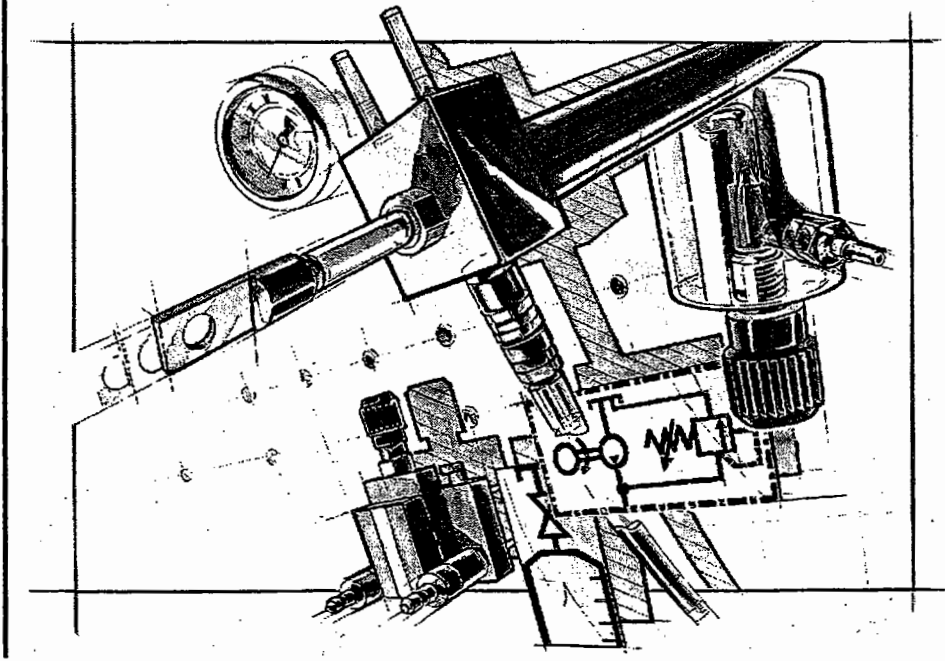

Basic Level TP501

# Hydraulics

The theoretical fundamentals for the "Hydraulics" training package are summarised in the textbook:

## Section B – Fundamentals



**Section C – Solutions**

- Solution 1: Automatic lathe C-3
- Solution 2: Package lifting device C-7
- Solution 3: Drawing press C-11
- Solution 4: Calender feeding device C-15
- Solution 5: Hardening furnace C-19
- Solution 6: Furnace door control C-23
- Solution 7: Conveyor tensioning device C-27
- Solution 8: Cold-store door C-33
- Solution 9: Rotary machining station C-37
- Solution 10: Painting booth C-41
- Solution 11: Embossing machine C-45
- Solution 12: Surface grinding machine C-49
- Solution 13: Drilling machine C-59
- Solution 14: Bulkhead door C-65
- Solution 15: Ferry loading ramp C-69
- Solution 16: Skip handling C-73
- Solution 17: Bonding press C-77
- Solution 18: Assembly device C-79
- Solution 19: Calculation for an assembly device C-83
- Solution 20: Tipping container C-85





Automatic lathe

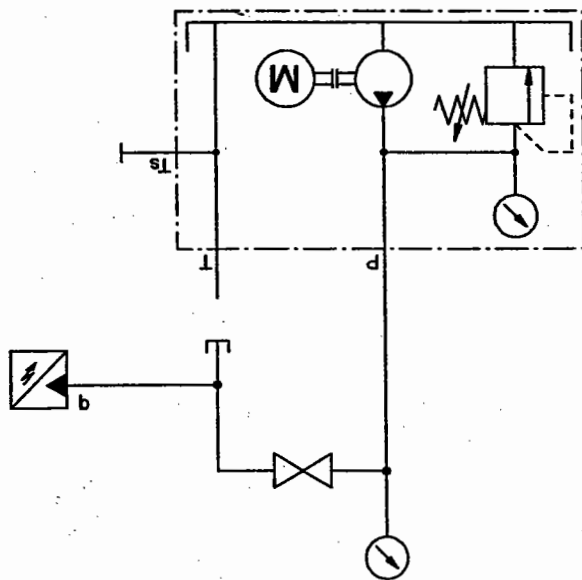
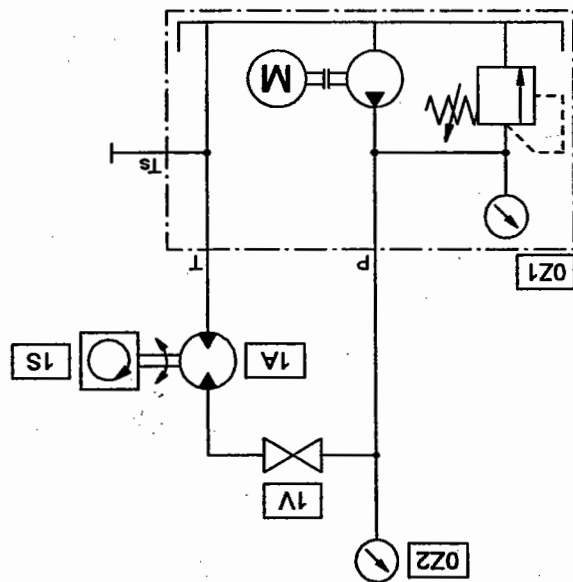

Circuit diagram, hydraulic

Practical assembly, hydraulic

Components list

Item no.	Qty.	Description
0Z1	1	Hydraulic power pack
0Z2	1	Pressure gauge
1V	1	Shut-off valve
1S	1	Flow sensor
	3	Hose line

Solution description

Once the hydraulic circuit has been assembled, valve 1V should be fully opened. Now close this valve slowly to set the first p value as shown on the pressure gauge 0Z2. The maximum attainable pressure is 60 bar, governed by a pressure relief valve built into the pump which is set to this value.

Evaluation

System pressure p	Flow rate q
15	2.33
20	2.31
25	2.29
30	2.28
35	2.26
40	2.24
45	2.22
50	2.20

Pump characteristic

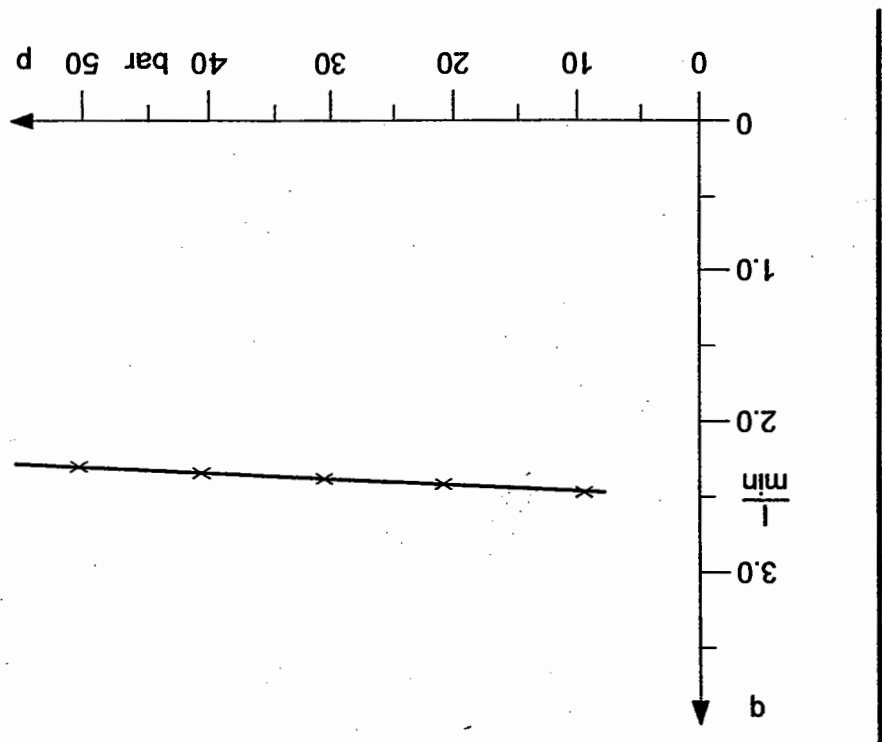

For technical reasons, the actual value recorded in this exercise is the power consumption of the electric motor or the premature opening of the pressure relief valve. The pump is dimensioned for a maximum pressure of 250 bar (see data sheet). An electric motor with an appropriately high rating would be required to achieve this. This would not, however, be meaningful, since the exercises are carried out with a maximum pressure of 60 bar.



As the pressure rises, the pump delivery falls slightly. In theory, the characteristic curve for the pump should be a straight line. The decrease in pump delivery is due to internal leakage losses, which become greater as the pressure increases. The ratio of the measured pump delivery and theoretical pump delivery is the effective volumetric efficiency of the pump.

*Conclusions*



Package lifting device

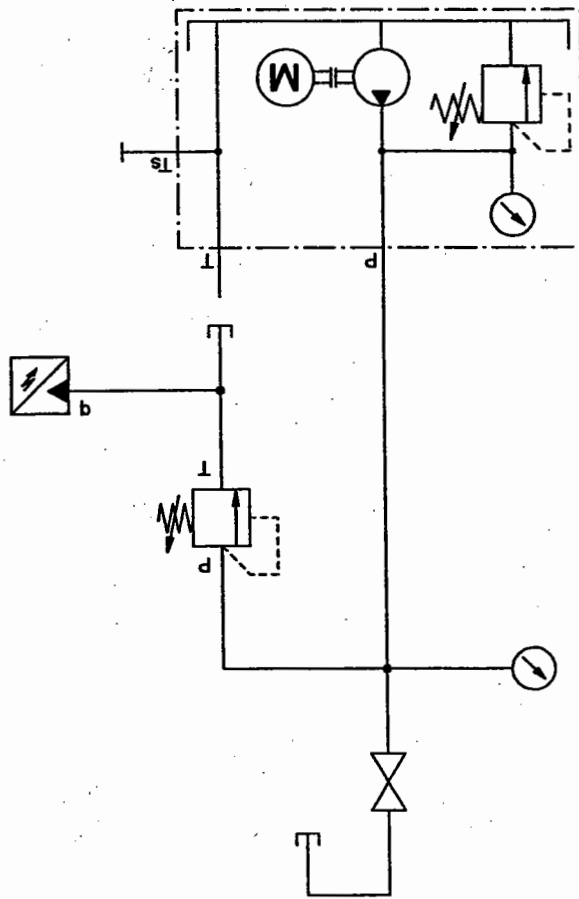

Circuit diagram, hydraulic

Practical assembly,  
hydraulic

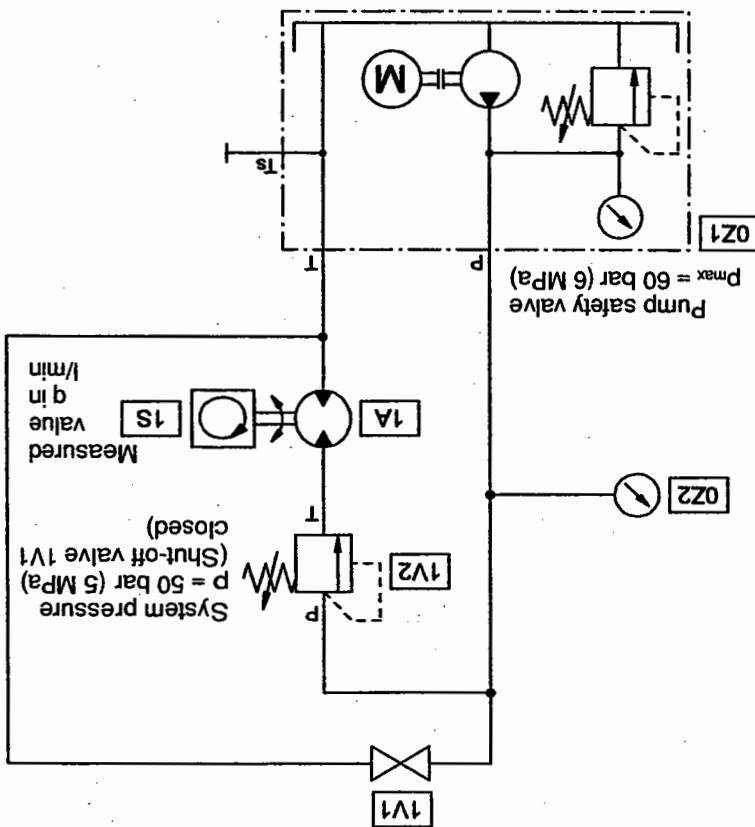

Components list

Item no.	Qty.	Description
0Z1	1	Hydraulic power pack
0Z2	1	Pressure gauge
1V1	1	Shut-off valve
1V2	1	Pressure relief valve
1S	1	Flow sensor
	5	Hose line
	2	Branch tee

*Solution description*

Once the hydraulic circuit has been assembled and checked, valve 1V1 should be closed and the pressure relief valve 1V2 fully opened. Switch on the hydraulic power pack and close the pressure relief valve until the pressure gauge 0Z2 indicates 50 bar. Now fully open shut-off valve 1V1 and close it again in steps to set the pressures specified in the table; evaluate the associated flow rates. At the same time, observe the pressure at which the valve begins to open.

**Remark** If, at 50 bar pressure, a flow rate of 2.3 l/min is not measured at the pressure relief valve, this indicates that the pressure relief valve fitted directly to the pump is already starting to open.

Working pressure p	Flow rate q
35	0
40	0
42.5	0
45	0.2
47.5	1.17
50	2.15

*Evaluation*

*Pressure relief valve characteristic*

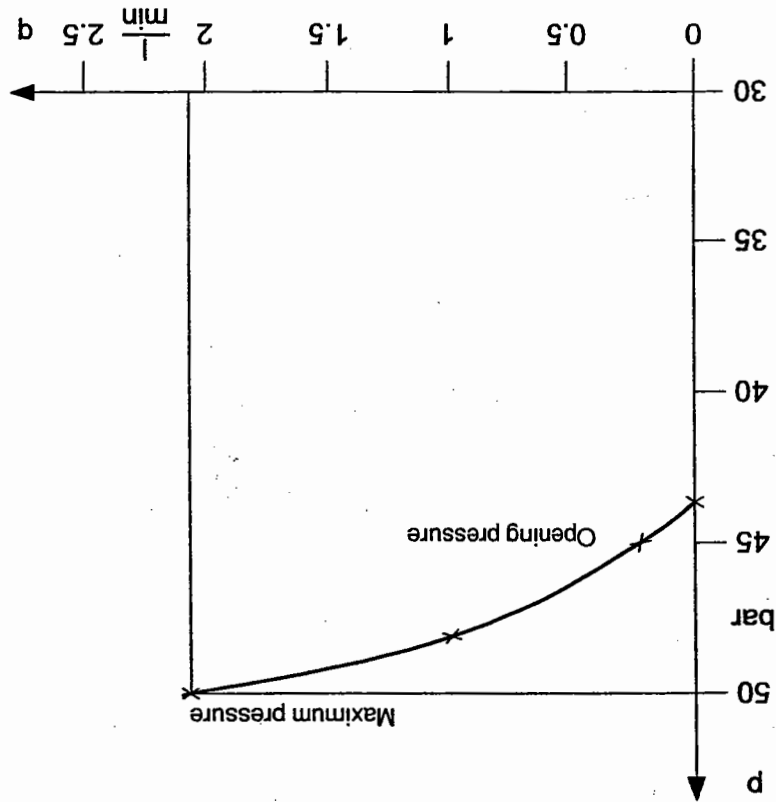

*Conclusions*

Every pressure relief valve has a certain opening pressure at which point diversion of the flow through the valve begins. The difference between opening pressure and maximum pressure is 5 bar in this case. When the preset maximum pressure is reached, the entire pump delivery is discharged via the pressure relief valve.



A piloted pressure relief valve can also be used to record the characteristic. Due to the low flow rate, the same shape of characteristic curve will be obtained.



Circuit diagram, hydraulic

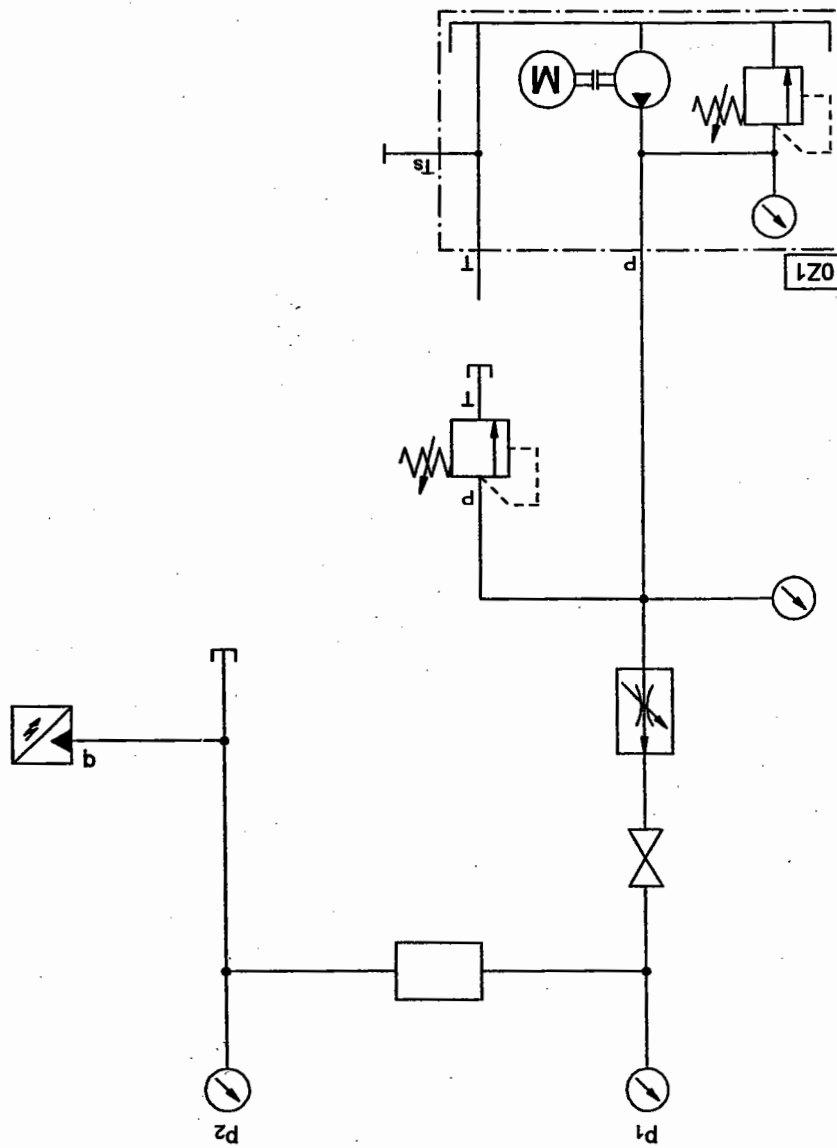

Drawing press

Practical assembly,  
hydraulic

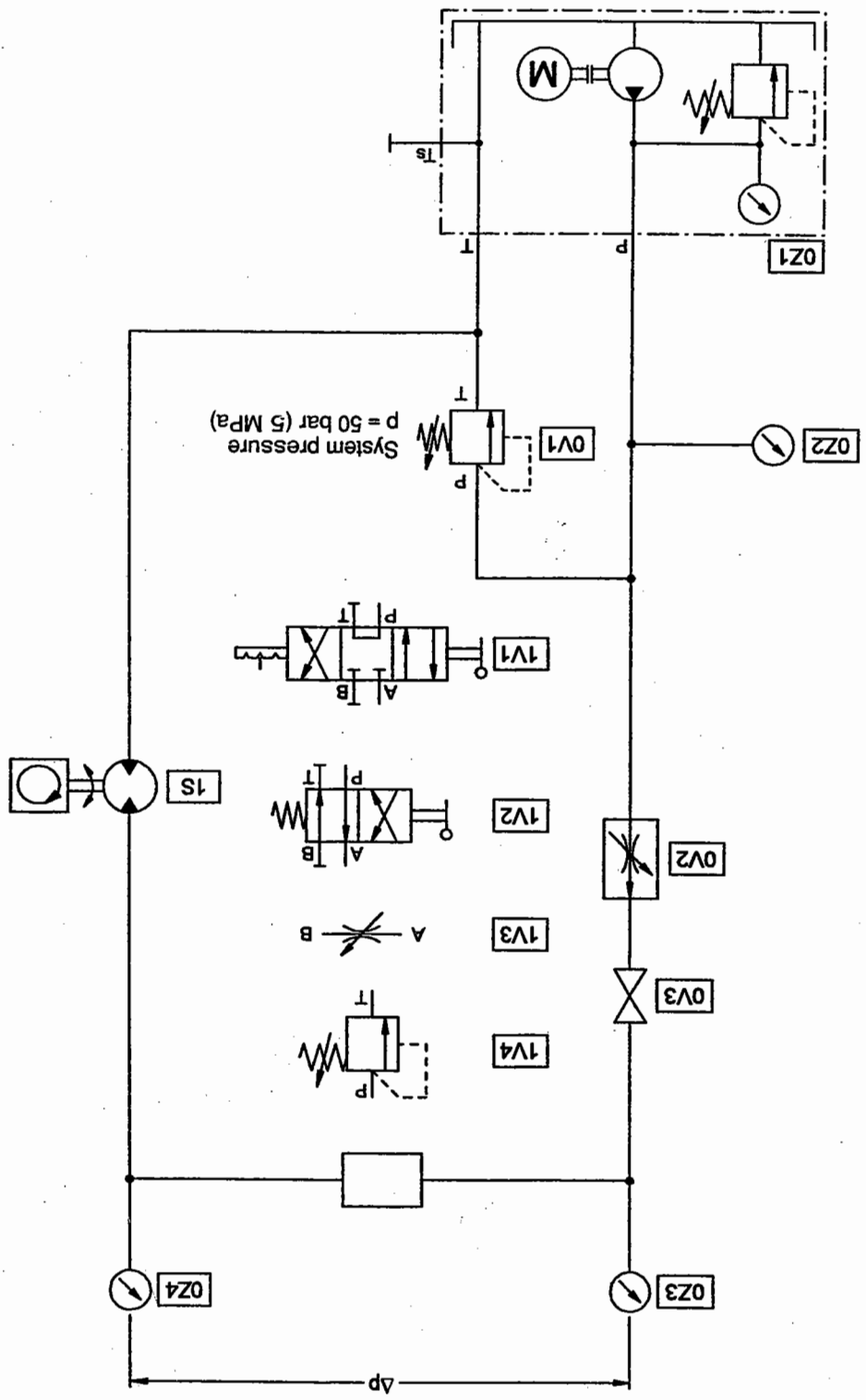

Components list

Item no.	Qty.	Description
0Z1	1	Hydraulic power pack
0Z2, 0Z3, 0Z4	3	Pressure gauge
0V1	1	Pressure relief valve
0V2	1	Flow control valve
0V3	1	Shut-off valve
1V4	1	Pressure relief valve
1V3	1	Throttle valve
1V2	1	4/2-way valve
1V1	1	4/3-way valve
1S	1	Flow sensor
	7	Hose line
	3	Branch tee

Solution description

Once the hydraulic circuit has been assembled and checked, the shut-off valve 0V3 should be closed and the pressure relief valve 0V1 fully opened. Switch on the hydraulic power pack and close the pressure relief valve until the pressure gauge 0V1 indicates 50 bar. Now carry out the series of measurements specified in the table. Adjust the flow rate by means of the flow control valve 0V2 and measure it with the flow sensor 1S.



Pressure sensors are recommended for the measurement of pressures at items 0Z3 and 0Z4.

**Evaluation**  
 $p_{0z3}$  = Pressure upstream of component  
 $p_{0z4}$  = Pressure downstream of component

Values table

Component	Flow rate $q$ l/min	Pressure $p_{0z3}$ bar	Pressure $p_{0z4}$ bar	Pressure difference $\Delta p$ bar
Pressure relief valve, fully open	2	4.6	2.5	2.1
Throttle valve, fully open	1	1.9	1.0	0.9
4/2-way valve, P → A	2	4.3	2.5	1.8
4/3-way valve, P → A	1	1.9	1.2	0.7
	2	4.3	2.5	1.8

**Conclusions**  
 When the flow rate doubles, the pressure difference increases by even more than this. The hydraulic resistance increases. This pressure loss means a loss of power.

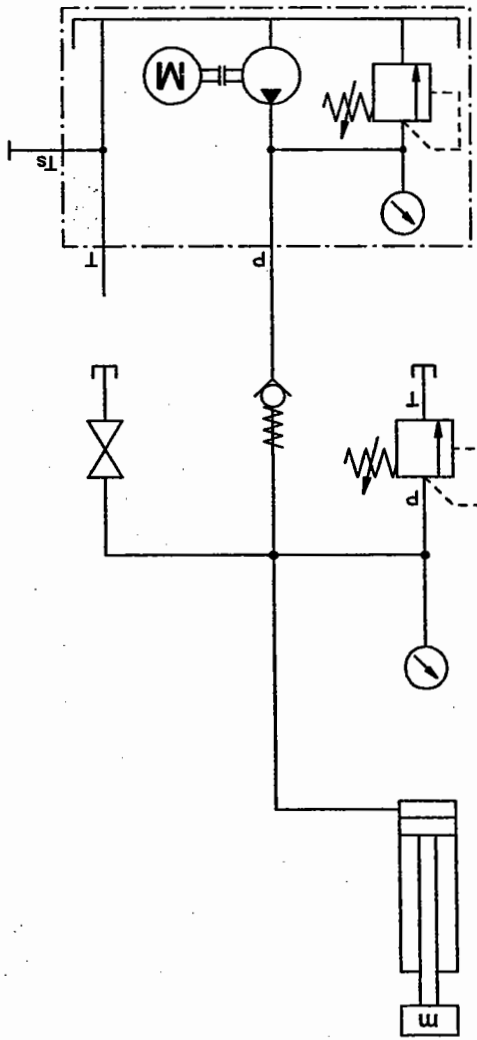

Calendar feeding device

Circuit diagram, hydraulic

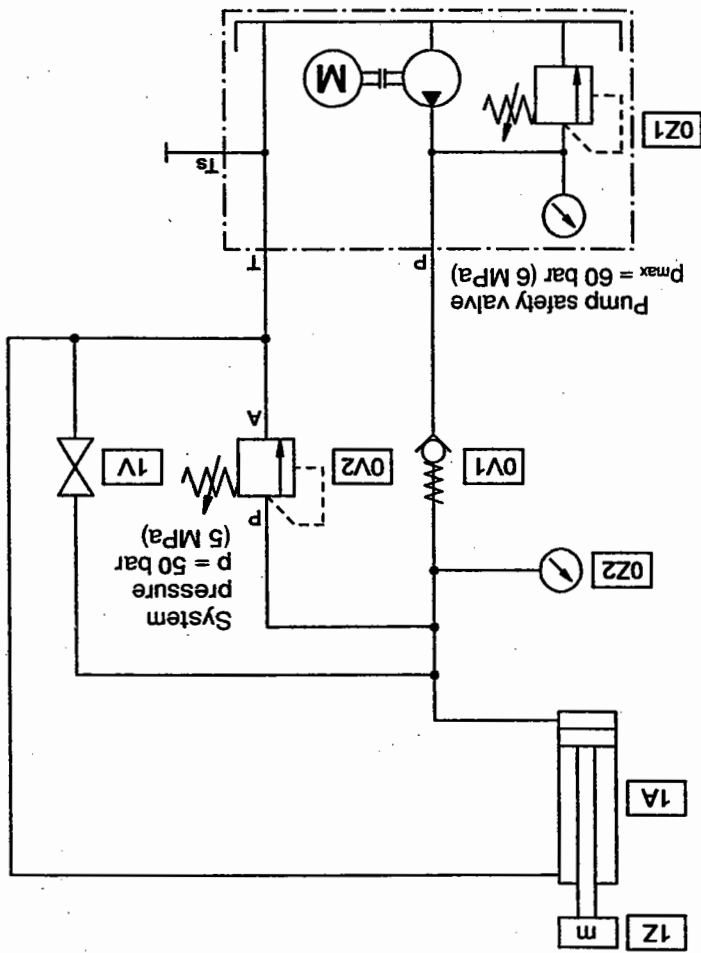

The piston rod can retract only when the pump is switched off. This is arranged intentionally in systems like the one shown here. This ensures that the hydraulic power pack is switched off during lengthy standstill periods.

*Conclusions*

For this exercise, the cylinder is bolted onto the base plate on the left of the profile plate and loaded with the weight. When the cylinder is connected up, it is essential that the upper connection is connected to the tank. Once the circuit has been assembled, the PRV 0V2 should first be fully opened. The hydraulic power pack should then be switched on and the PRV 0V2 slowly closed. The piston rod will then travel to its upper end position. Continue to close the PRV until the pressure gauge 0Z2 indicates 50bar. Now switch off the hydraulic power pack. It can be demonstrated by briefly opening the shut-off valve that the non-return valve prevents the weight from lowering further and that return flow of hydraulic fluid during the return stroke can take place only via the 2/2-way valve 1V.

*Solution description*

Item no.	Qty.	Description
0Z1	1	Hydraulic power pack
0V1	1	Non-return valve (5 bar)
0Z2	1	Pressure gauge
0V2	1	Pressure relief valve
1V	1	Shut-off valve
1A	1	Cylinder, double-acting
1Z	1	Loading weight
	8	Hose line
	4	Branch tee

*Components list*





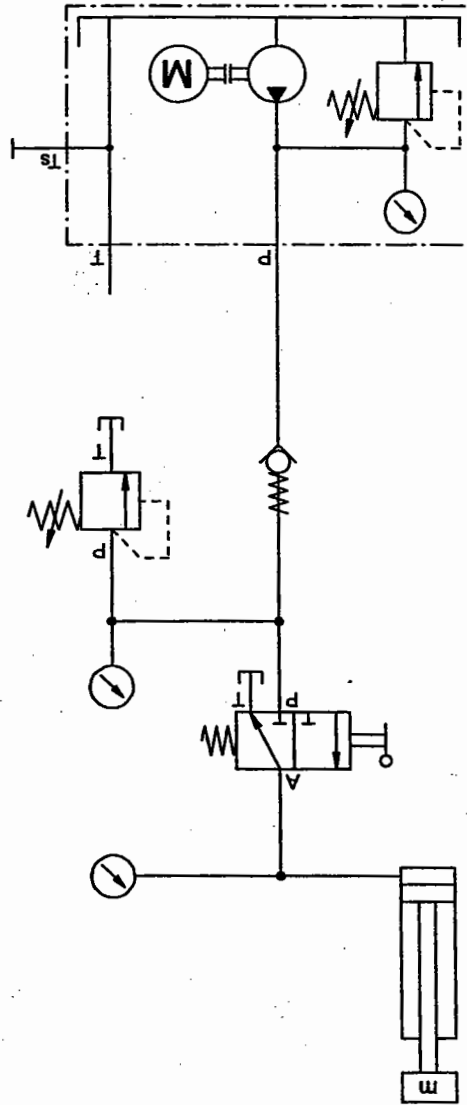

Hardening furnace

Circuit diagram, hydraulic

Practical assembly,  
hydraulic

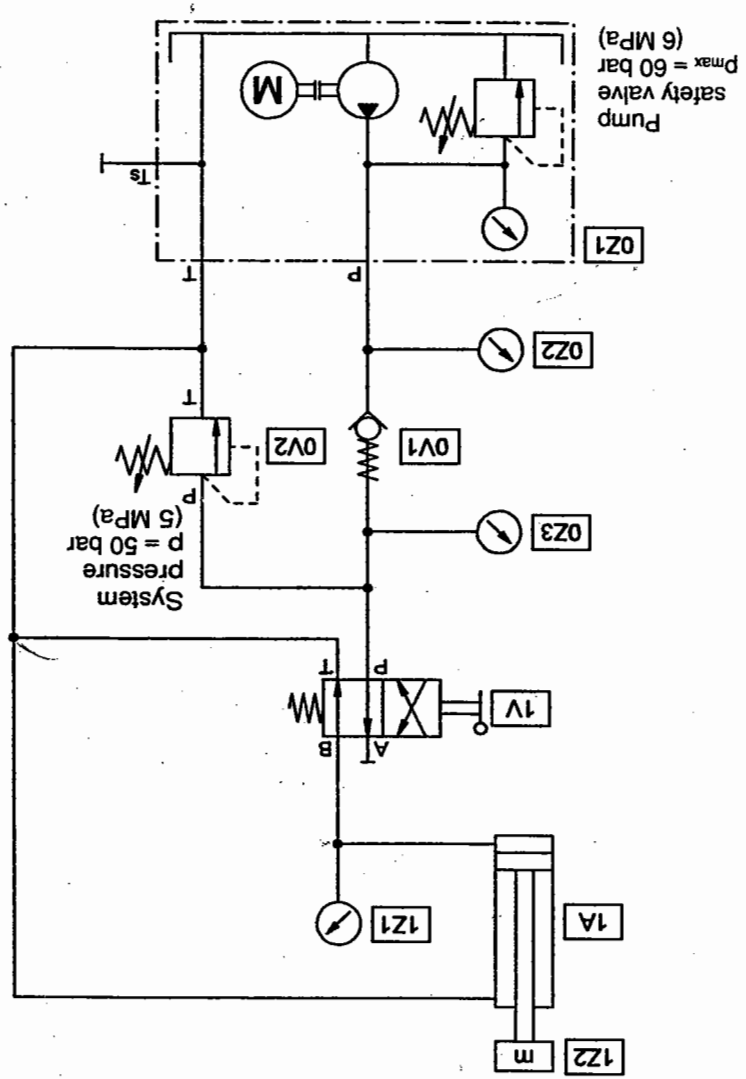

Direction	Travel pressure	Travel time
Advance stroke	8 bar	1.1 s
Return stroke	0 bar	1.4 s

Evaluation

The values specified in the tables can now be measured.

For this exercise, the cylinder is bolted onto the base plate on the left of the profile plate and loaded with the weight. When the cylinder is connected up, it is essential that the upper connection is connected to the tank. In place of a 3/2-way valve, a 4/2-way valve is now used, with one connection blanked off. Once the circuit has been assembled, the PRV 0V2 should first be fully opened. The hydraulic power pack should then be switched on and the PRV 0V2 slowly closed until the pressure gauge 0Z3 indicates 50 bar. The 4/2-way valve 1V can now be slowly reversed, which will cause the piston rod of the cylinder to advance. The design of the valve means that, as this is slowly reversed, the full cross-section of the valve is not immediately opened. Initially, the pump delivery to the cylinder will be throttled. As soon as the valve is returned to its initial position, the piston rod of the cylinder will return to its lower end position.

Solution description

Item no.	Qty.	Description
0Z1	1	Hydraulic power pack
0Z2, 0Z3, 1Z1	3	Pressure gauge
0V1	1	Non-return valve
0V2	1	Pressure relief valve
1V	1	4/2-way valve, manually operated
1A	1	Cylinder, double-acting
1Z2	1	Loading weight
	7	Hose line
	3	Branch tee
	1	Stop-watch

Components list

Characteristic data required for calculation:

Applied load:  $F_w = 90 \text{ N}$

Piston area:  $A_{PN} = 2 \text{ cm}^2$

Stroke length:  $s = 200 \text{ mm}$

Pump delivery:  $q = 2 \text{ l/min}$

Load pressure:  $p_L = \frac{F_w}{A_{PN}} = \frac{90 \text{ N}}{2 \text{ cm}^2} = \frac{45 \text{ N}}{\text{cm}^2} = 4.5 \text{ bar}$

Hydraulic resistance = Travel pressure - load pressure

$p_{\text{res}} = 8 \text{ bar} - 4.5 \text{ bar} = 3.5 \text{ bar}$

Conclusions

The back pressure is considerably lower than the hydraulic resistance. A cylinder motion can take place only if this case applies. The value of the back pressure depends on the hydraulic resistances. These are very low when fluid is discharged into the tank.

Advance-stroke speed:  $v_{\text{adv}} = \frac{q}{A_{PN}} = \frac{2 \frac{\text{min}}{\text{min}}}{2 \text{ cm}^2} = \frac{2000 \text{ cm}^3}{60 \text{ s}} = \frac{1}{30} \frac{\text{cm}^3}{\text{s}} = 0.033 \frac{\text{cm}^3}{\text{s}}$

$v_{\text{adv}} = 16.67 \frac{\text{cm}}{\text{s}} = 0.17 \frac{\text{m}}{\text{s}}$

Advance-stroke time:  $t_{\text{adv}} = \frac{s}{v_{\text{adv}}} = \frac{0.2 \text{ m}}{0.17 \frac{\text{m}}{\text{s}}} = 1.2 \text{ s}$

Conclusions

The measured advance-stroke time, 1.1 s, is slightly less than the calculated time. The reason for this may be that the delivery of a new pump is somewhat greater than 2 l/min.

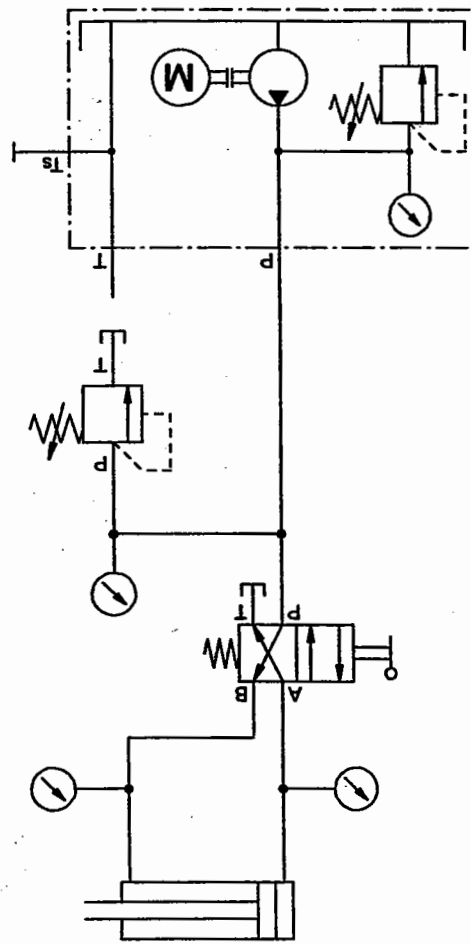

Furnace door control

Circuit diagram, hydraulic

Practical assembly,  
hydraulic

Item no.	Qty.	Description
0Z1	1	Hydraulic power pack
0Z2	1	Pressure gauge
1S1, 1S2	2	Pressure sensor
0V	1	Pressure relief valve
1V	1	4/2-way valve, manually operated
1A	1	Cylinder
	6	Hose line
	2	Branch tee
	1	Stop-watch

Components list

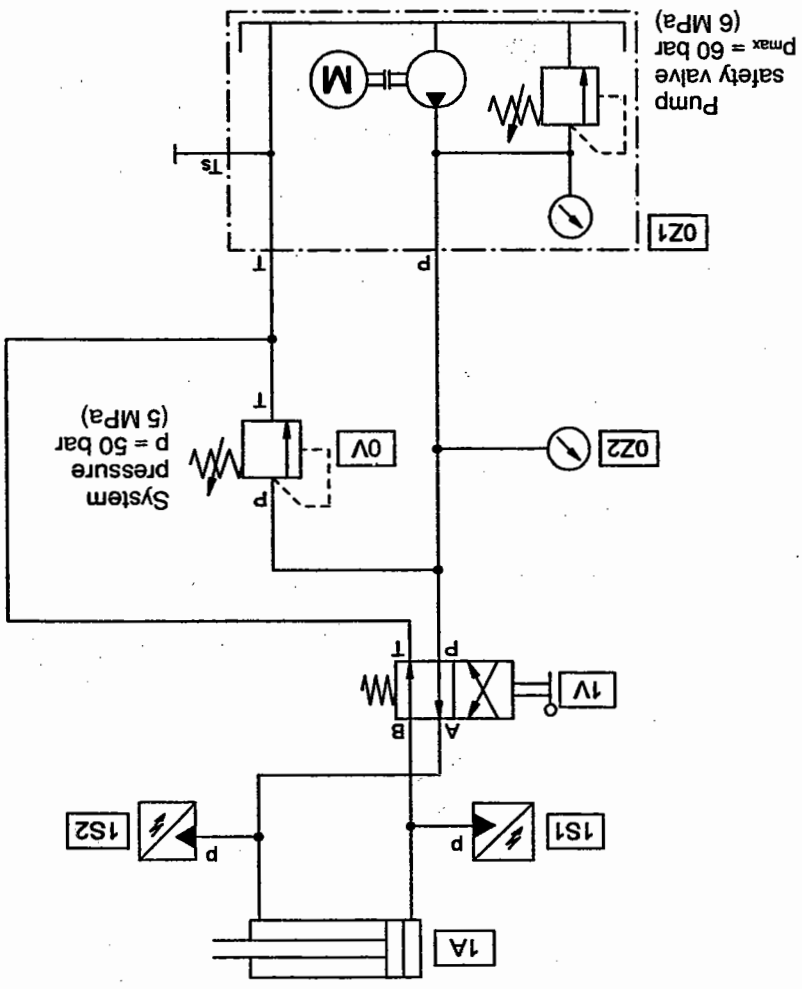

Solution description

Once the circuit has been assembled and checked, the hydraulic power pack should be switched on and the system pressure set on the pressure relief valve 0V to 50 bar. Pressure sensors should be used to measure the travel and back pressures. Pressure gauges are sluggish in operation and would give incorrect readings.

When the hand lever of the 4/2-way valve is actuated, the piston rod of the cylinder will advance until the lever is released or the piston rod runs against the stop. When the lever is released, the piston rod will immediately return to its retracted end position. Before the pressures and times are measured, the piston rod should be advanced and retracted several times to expel any air which may have entered the piston-rod chamber during the previous exercises.

Advance stroke	Travel pressure	$p_{1s1}$	2.4 bar	Travel time	1.2 s
	Back pressure	$p_{1s2}$	2 bar	Travel time	0.8 s
Return stroke	Travel pressure	$p_{1r1}$	5.3 bar	Travel pressure	11 bar
	Back pressure	$p_{1r2}$	11 bar	Travel time	0.8 s

Evaluation

Characteristic data required for calculation:

Piston area:  $A_{PN} = 2.0 \text{ cm}^2$

Piston annular area:  $A_{PR} = 1.2 \text{ cm}^2$

Stroke length:  $s = 200 \text{ mm}$

Pump output:  $q = 2 \text{ l/min}$

Area ratio:  $\alpha = \frac{A_{PN}}{A_{PR}} = \frac{2 \text{ cm}^2}{1.2 \text{ cm}^2} = 1.667$

Advance-stroke speed:  $v_{adv} = \frac{q}{A_{PN}} = \frac{2 \frac{\text{l}}{\text{min}}}{2 \frac{\text{cm}^2}{\text{min}}} = \frac{1}{60 \text{ s}} \frac{2000 \text{ cm}^3}{2 \text{ cm}^2} = 16.67 \frac{\text{cm}}{\text{s}} = 0.17 \frac{\text{m}}{\text{s}}$

$v_{adv} = 16.67 \frac{\text{cm}}{\text{s}} = 0.17 \frac{\text{m}}{\text{s}}$

Advance-stroke time:  $t_{adv} = \frac{V_{adv}}{s} = \frac{2 \text{ m}}{0.17 \frac{\text{m}}{\text{s}}} = 12 \text{ s}$

Return-stroke speed:  $V_{ret} = \frac{q}{A_{PR}} = \frac{2 \frac{\text{min}}{\text{min}}}{\frac{1}{2000 \text{ cm}^3} \cdot 12 \text{ cm}^2} = \frac{60 \text{ s}}{12 \text{ cm}^2}$

$$V_{ret} = 27.78 \frac{\text{cm}}{\text{s}} = 0.28 \frac{\text{m}}{\text{s}}$$

Return-stroke time:  $t_{ret} = \frac{s}{V_{ret}} = \frac{0.2 \text{ m}}{0.28 \frac{\text{m}}{\text{s}}} = 0.7 \text{ s}$

Travel speed ratio:  $\frac{V_{adv}}{V_{ret}} = \frac{0.17 \frac{\text{m}}{\text{s}}}{0.28 \frac{\text{m}}{\text{s}}} = 0.6$

Travel time ratio:  $\frac{t_{adv}}{t_{ret}} = \frac{12 \text{ s}}{0.7 \text{ s}} = 17$

*Conclusions* The travel speed ratio is equal to the area ratio  $\alpha$  of the cylinder. The speed ratio is equal to the reciprocal of the area ratio.



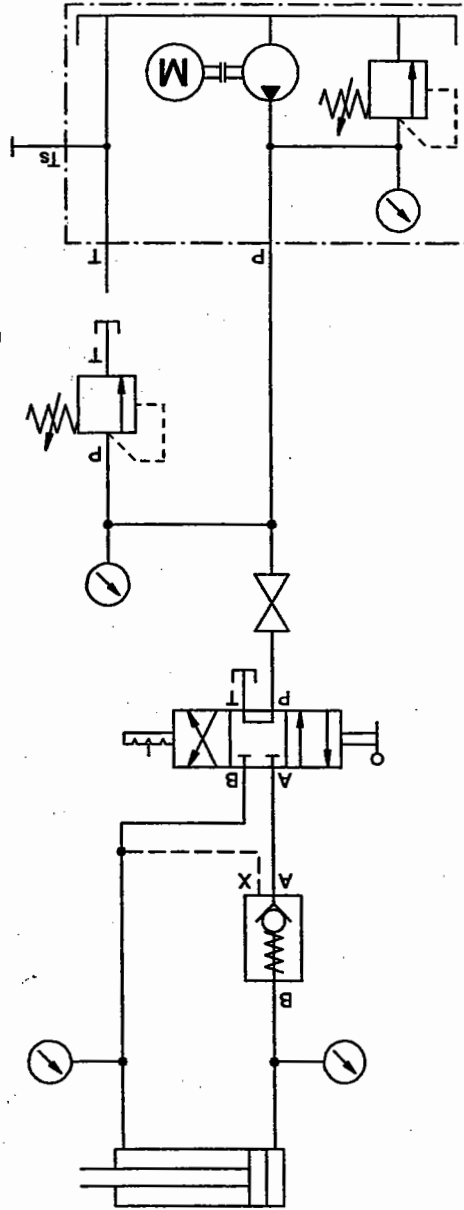

Conveyor tensioning device

Circuit diagram, hydraulic

Practical assembly,  
hydraulic

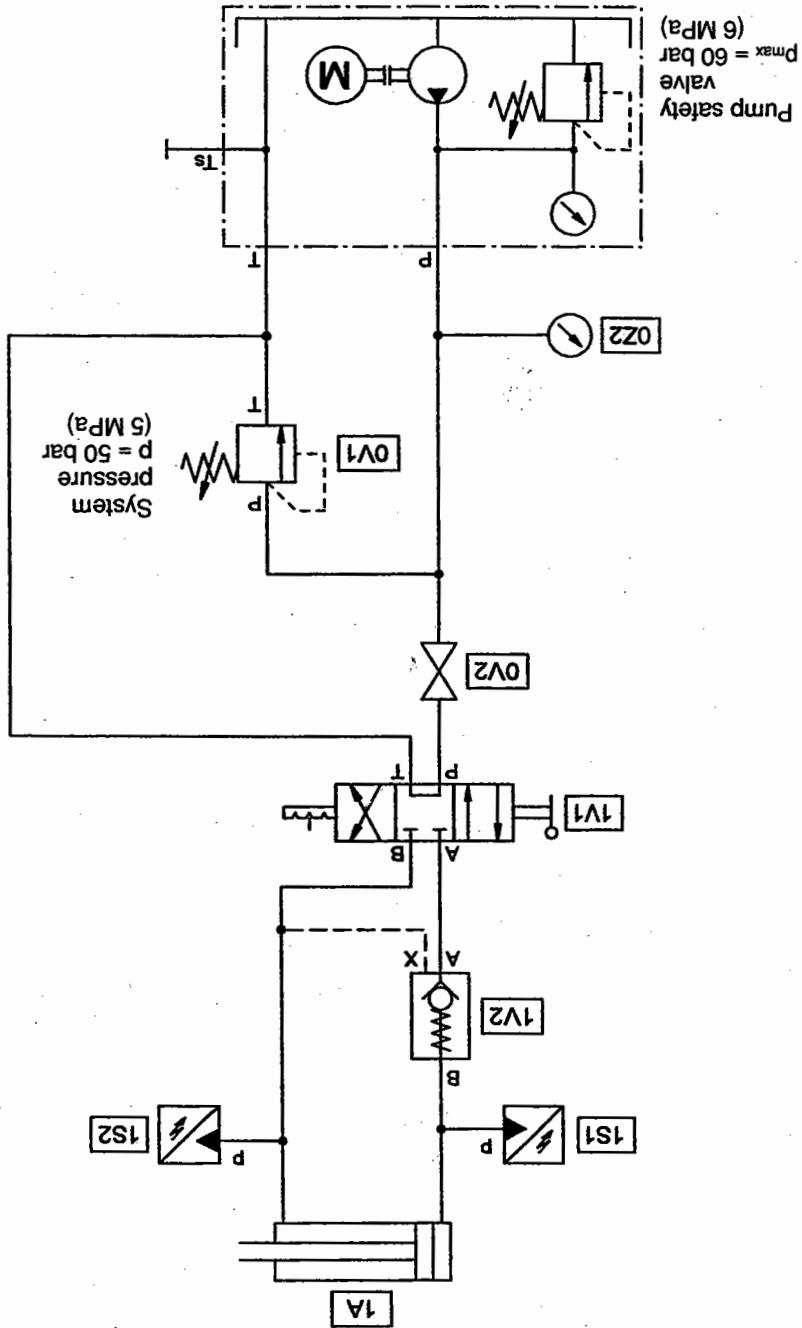

After the circuit has been assembled and tested, the shut-off valve 0V2 should be closed and the pressure relief valve 0V1 opened. Switch on the hydraulic power pack and close the PRV 0V1 until the pressure gauge 0Z1 indicates 50 bar.

The shut-off valve 0V2 can now be opened. Observe when doing this that the pressure gauge 0Z1 shows an immediate drop from the set pressure of 50 bar to approx. 3 bar, since in its mid-position the 4/3-way valve 1V1 discharges the flow of hydraulic fluid to the tank. The piston rod can be brought into any desired position by actuating the 4/3-way valve. When this valve is brought into its mid-position, the piston rod immediately halts.

The non-return valve prevents the piston rod from being pushed back by a counter force.

*Solution description*

Item no.	Qty.	Description
0Z1	1	Hydraulic power pack
0Z2	1	Pressure gauge
1S1, 1S2	2	Pressure sensor
0V1	1	Pressure relief valve
0V2	1	Shut-off valve
1V1	1	4/3-way valve, manually operated, Recirculating mid-position
1V2	1	Pilot-operated non-return valve
1A	1	Cylinder
	9	Hose line
	3	Branch tee
	1	Stop-watch

*Components list*

In conjunction with the pilot-operated non-return valve, a 4/3-way valve with a mid-position "A and B connected to T" and "P closed" should be used in order to depressure the pilot line and supply line to the piloted non-return valve. The non-return valve can close reliably only when depressured.

The 4/3-way valve with recirculating mid-position, included in the equipment set, can also be used for these exercises. The internal leakage losses resulting from the design of this valve will also cause the non-return valve to close.



Evaluation

Direction	Valve position	System pressure	Travel and back pressure
Advance stroke		8 bar	2.2 bar
Return stroke		2.2 bar	9.4 bar
Mid-position		3.1 bar	1.6 bar
			1.7 bar

Calculation of drive power::  $P_{DR} = \frac{p \cdot q}{\eta}$

Characteristic data required for calculation:

- $P_{DR}$  = Required drive power
- $p$  = System pressure supplied by pump: Maximum 50 bar
- $q$  = Flow rate of pump: Constant 2 l/min
- $\eta$  = Pump efficiency: Approx. 0.7

Drive power with closed mid-position:

$$P_{DR} = \frac{50 \text{ bar} \cdot 2 \frac{\text{l}}{\text{min}}}{0.7} = \frac{50 \text{ kp} \cdot 2 \text{ dm}^3}{0.7 \text{ cm}^2 \cdot 60 \text{ s}} = \frac{50 \cdot 10 \text{ N} \cdot 2 \cdot 1000 \text{ cm}^3}{0.7 \text{ cm} \cdot 60 \text{ s}}$$

$$P_{DR} = \frac{50 \cdot 2}{0.7 \cdot 60} \cdot 10000 \frac{\text{Ncm}^3}{\text{cm}^2 \cdot \text{s}} = \frac{50 \cdot 2}{0.7 \cdot 60} \cdot 100 \frac{\text{Nm}}{\text{s}} = 238 \text{ W}$$

Drive power with bypass to pump:

$$P_{DR} = \frac{3.1 \text{ bar} \cdot 2 \frac{\text{l}}{\text{min}}}{0.7} = \frac{3.1 \cdot 2}{0.7 \cdot 60} \cdot 100 \frac{\text{Nm}}{\text{s}} = 15 \text{ W}$$

The 4/3-way valve with recirculating mid-position is mainly used in cases where a cylinder or motor is driven by a constant-displacement pump. In the recirculating mid-position, hydraulic fluid is discharged to the tank at almost zero pressure, which means that the temperature rise remains small. The disadvantage of using this valve is that it is not possible to operate any further hydraulic circuits.

In the case of valves with a closed position for connection P, the pump delivery is discharged to the tank at maximum system pressure, which results in pronounced heating of the fluid (= energy loss).

Conclusions





Practical assembly,  
hydraulic

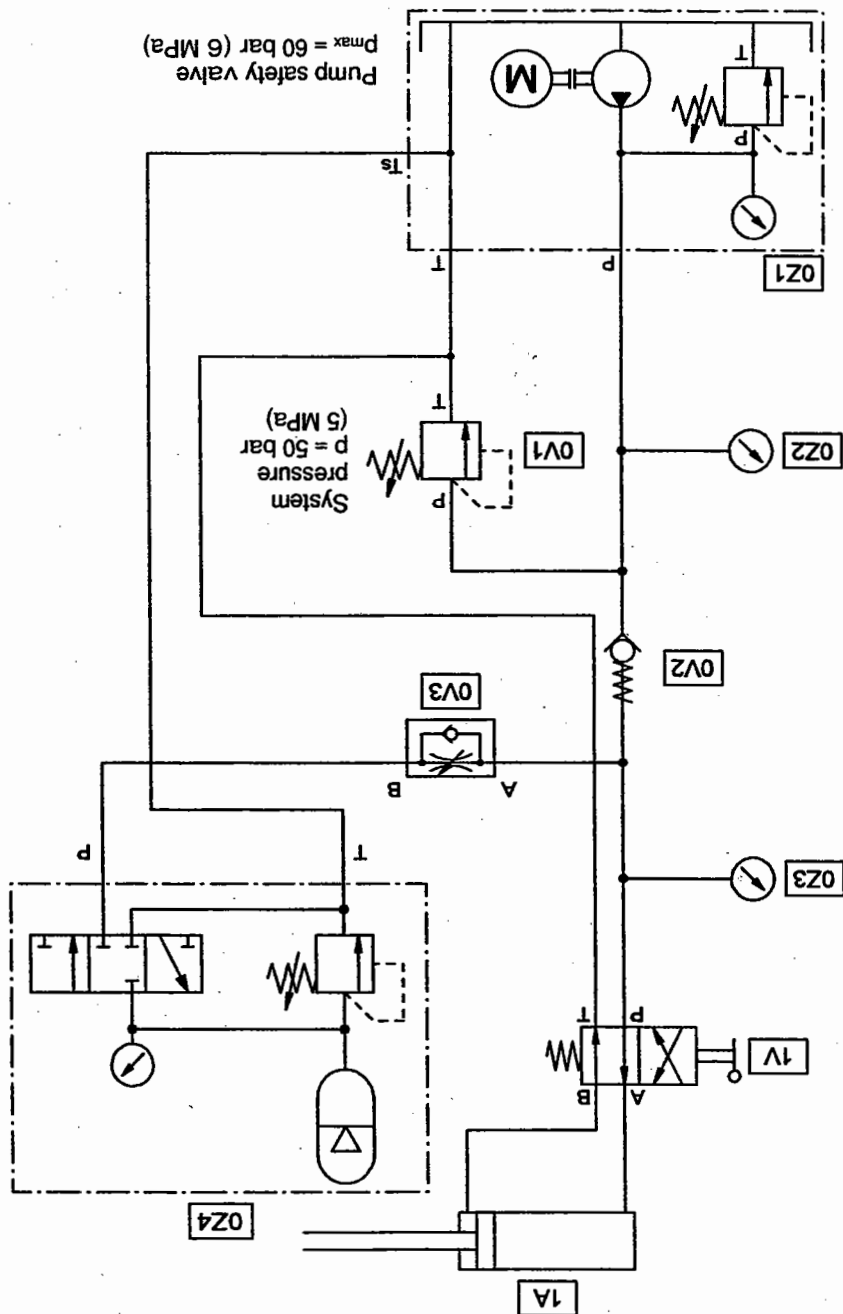



System pressure	Opening	Closing
50 bar	4 x	3 x
20 bar	2 x	1 x

Evaluation

After the circuit has been assembled and checked, the accumulator should first be switched off and the pressure relief valve 0V1 fully opened. Now switch on the hydraulic power pack and set the system pressure to 50 bar. The accumulator can now be charged. Allow the cylinder to advance and retract several times and then switch off the hydraulic power pack. It is possible to advance and retract the cylinder several times more by actuating the 4/2-way valve 1A. Following this, the accumulator pressure will fall slowly, as indicated by the pressure gauge 0V3. Be sure to switch off and depressurise the accumulator before dismantling the circuit!

Solution description

Item no.	Qty.	Description
0Z1	1	Hydraulic power pack
0Z2, 0Z3	2	Pressure gauge
0V1	1	Pressure relief valve
0V2	1	Non-return valve
0V3	1	One-way flow-return valve, adjustable
0Z4	1	Diaphragm accumulator
1V	1	4/2-way valve, manually operated
1A	1	double-acting Cylinder
	7	Hose line
	3	Branch tee

Components list

*Conclusions*

Without the accumulator fitted, the door will remain in its instantaneous position after a power failure and it will no longer be possible to move it. This diaphragm accumulator allows the door to be opened 2 x and closed 1 x with a system pressure of 20 bar and opened 4 x and closed 3 x with a system pressure of 50 bar. The higher the hydraulic pressure with which the accumulator is charged, the more times the door can be opened and closed.

*Design*

In the case of a diaphragm accumulator, a diaphragm is clamped into place in the pressure vessel to act as a divider between the hydraulic fluid and the gas cushion (nitrogen). A gas valve is fitted at the top to allow the accumulator to be pressurised with gas via a filling device. A closure head is fitted to the diaphragm or a shut-off valve to the gas inlet to prevent the diaphragm from creeping into the gas inlet as the gas is discharged and becoming damaged. The accumulator used here has an initial gas pressure rating of 10 bar and a nominal volume of 0.32 cm<sup>3</sup>. All accumulators must be fitted with a lead-sealed safety pressure relief valve and a shut-off valve, as appropriate to their capacity.

*Mode of operation*

When hydraulic fluid is forced into the accumulator, this causes a corresponding reduction in the volume of the gas. At the same time, the pressure in the gas cushion rises until the gas and hydraulic fluid are at the same pressure. When the fluid pressure falls, the gas forces fluid back into the hydraulic system. A non-return valve must be fitted upstream of the pump to prevent stored fluid from being discharged via the pump when this is switched off. Comprehensive manufacturers' tables are available for use when sizing accumulators. In addition to diaphragm and bladder accumulators, piston accumulators are also available if large capacities are required.

*Examples of applications*

- Accumulators are used for the following:
- Compensation for leakage losses
  - Energy reserve in emergencies
  - Compensation for peaks in flow rate demand
  - Cushioning of switching joints

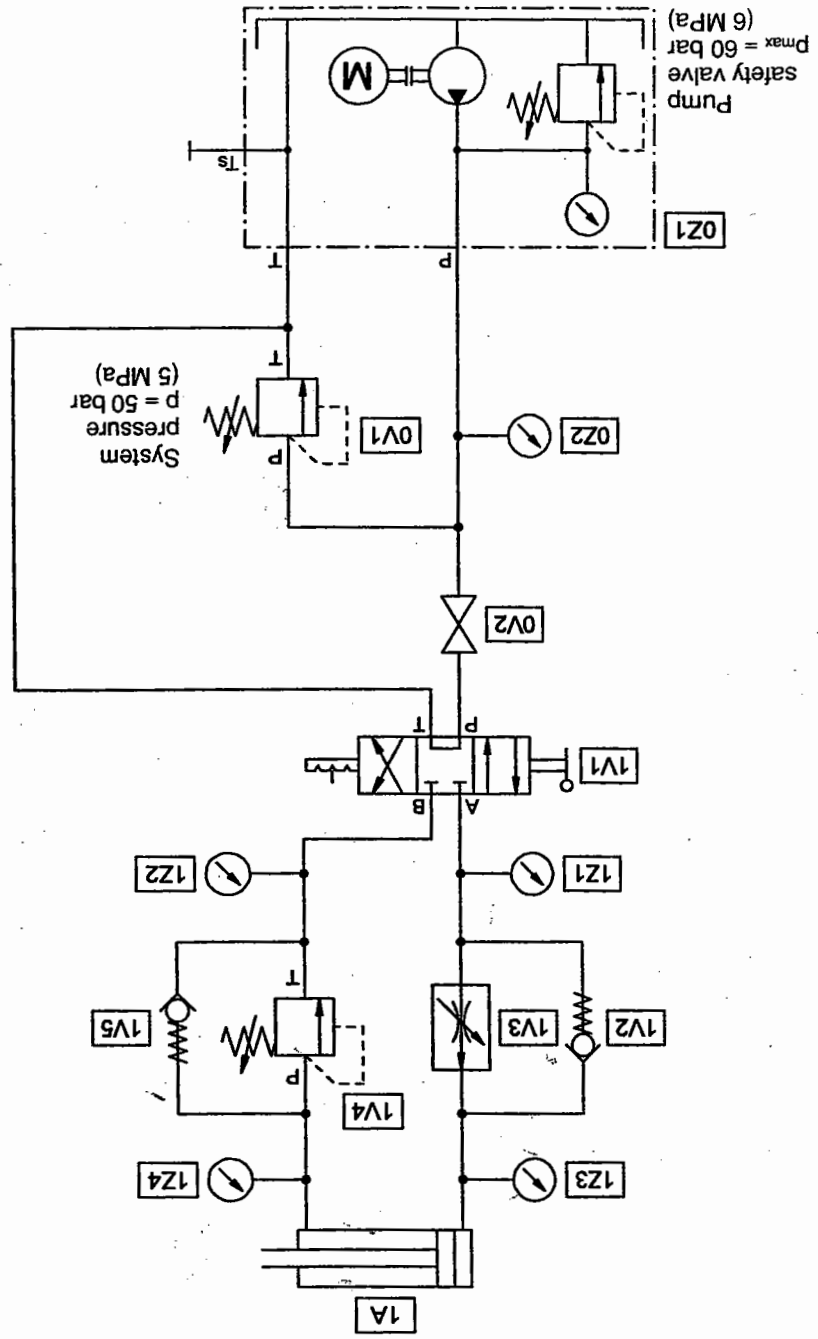

Rotary machining station

Practical assembly,  
hydraulic

Components list

Item no.	Qty.	Description
0Z1	1	Hydraulic power pack
0Z2, 1Z1, 1Z2, 1Z3, 1Z4	5	Pressure gauge
0V1, 1V4	2	Pressure relief valve
0V2	1	Shut-off valve
1V1	1	4/3-way valve, manually operated
1V3	1	2-way flow control valve
1V2, 1V5	2	Non-return valve
1A	1	Cylinder
	12	Hose line
	6	Branch tee
	1	Stop-watch

Solution description

Assemble and check the circuit. Close the shut-off valve 0V2 and set the desired pressure by means of the pressure relief valve 0V1.

Now open the pressure relief valve 1V4 and the shut-off valve 0V2. Open the flow control valve approx. 2 turns so that the piston rod moves into its forward end position in approx. 5 sec., when the 4/3-way valve is actuated. Do not make any further changes to the flow control valve setting. As soon as the piston rod reaches the forward end position with the 4/3-way valve actuated, use the pressure relief valve 0V1 to set the values in table 1 (check these on the pressure gauge 1Z1).

The pressure as indicated on the pressure gauge 1Z4 must be set during the advance stroke, using the pressure relief valve 1V4. Flow is not possible through the flow control valve and pressure relief valve in the opposite direction. The two non-return valves 1V2 and 1V5 are fitted to allow these to be bypassed.



In the case of settings  $p_{1Z1} = 50$  bar and  $p_{1Z4} = 40$  bar (in tables 1 and 2), the pump requires approx. 1-2 sec. to build up a counter pressure of 40 bar. The time should therefore be measured not from the moment the 4/3-way valve is actuated but from the moment the piston rod starts to move. In the case of table 2, the specified values of 50 bar cannot be fully reached due to the resistances present.

Evaluation

- $p_{1z1}$  = Pressure upstream of flow control valve
- $p_{1z3}$  = Pressure downstream of flow control valve
- $p_{1z4}$  = Pressure at counter-holding valve
- $t \rightarrow$  = Cylinder advance-stroke time

Fluctuating inlet pressure	$p_{1z1}$	$p_{1z3}$	$p_{1z4}$	$t \rightarrow$
50 bar	7 bar	7 bar	10 bar	4 s
40 bar	7 bar	7 bar	10 bar	4 s
30 bar	7 bar	7 bar	10 bar	4 s
20 bar	7 bar	7 bar	10 bar	4 s
10 bar	7 bar	7 bar	10 bar	6 s
Fluctuating outlet pressure	$p_{1z1}$	$p_{1z3}$	$p_{1z4}$	$t \rightarrow$
50 bar	7 bar	7 bar	10 bar	4 s
50 bar	13 bar	13 bar	20 bar	4 s
50 bar	20 bar	20 bar	30 bar	4 s
50 bar	26 bar	26 bar	40 bar	4 s
50 bar	32 bar	32 bar	50 bar	4 s

Conclusions

Even with modified pressures at the inlet and outlet, the piston advance-stroke times remain constant. The flow rate will be inadequate only if the supply pressure is too low.

The pressure intensification effect becomes noticeable with higher counter pressure; the advance-stroke speed falls only when the counter pressure reaches approx. 70 bar. The pressure reached on the piston rod side is then 48 bar.



This exercise is also suitable for practice with fault-finding. If the non-return valves are installed incorrectly, the piston rod will not retract. The cause of this can be identified by systematic observation of the pressure-gauge readings.



Painting booth

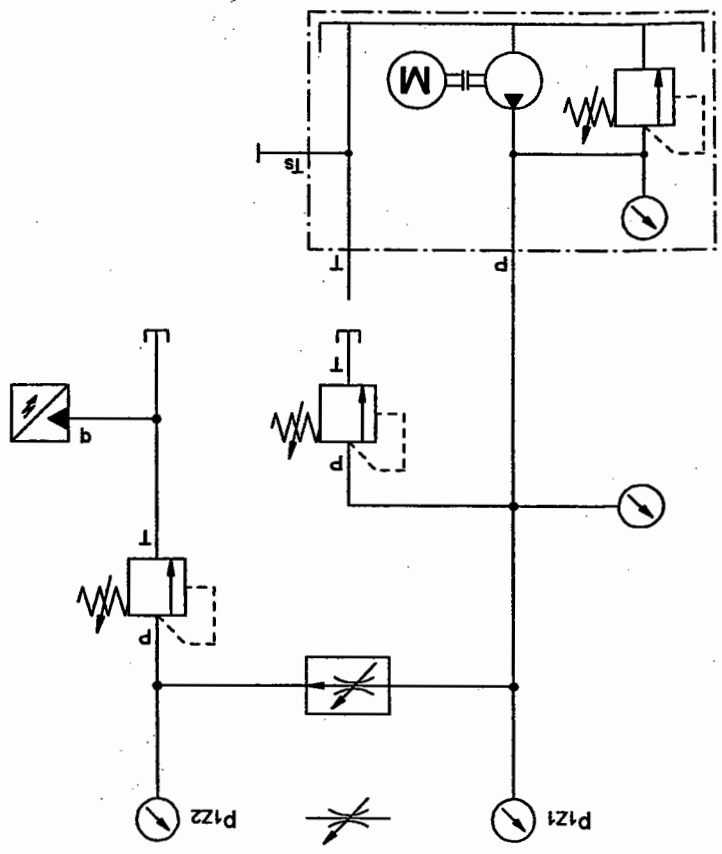

Circuit diagram, hydraulic

Practical assembly,  
hydraulic

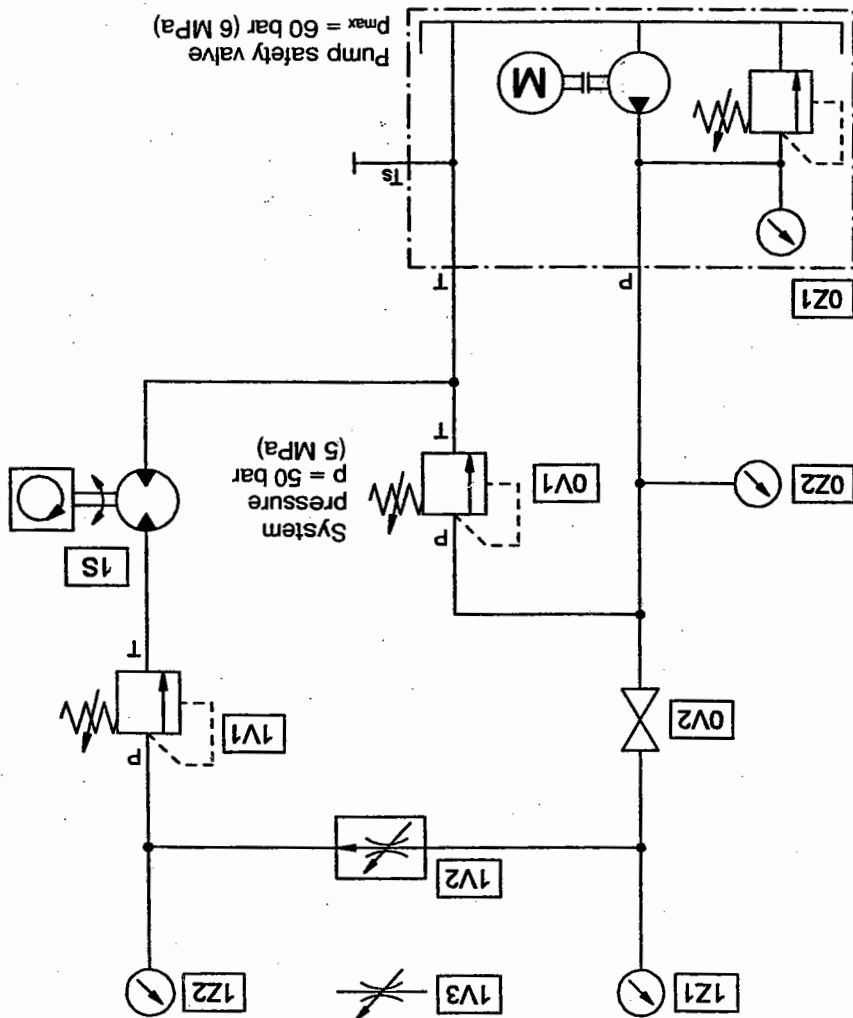

Components list

Item no.	Qty.	Description
OZ1	1	Hydraulic power pack
OZ2, 1Z1, 1Z2	3	Pressure gauge
OV1, 1V1	2	Pressure relief valve
OV2	1	Shut-off valve
1S	1	Flow sensor
1V2	1	Flow control valve
1V3	2	Throttle valve
	6	Hose line
	2	Branch tee



Solution description

Assemble and check the circuit in accordance with the circuit diagram. Fully open the pressure relief valves 0V1 and 1V1 and close the shut-off valve 0V2. Open the flow control valve 0Z2 approx. 2 turns. The hydraulic power pack can now be switched on. The system pressure of 50 bar required for the exercise should be set on the pressure relief valve 0V1 and checked on the pressure gauge 0Z2.

Now open the shut-off valve 0V2. If the pressure gauge 1Z1 shows less than 50 bar, re-adjust the pressure relief valve 0V1 slightly. The flow control valve 0V2 can now be set to the desired flow rate of 2 l/min.

The load pressure should be varied by means of the pressure relief valve 1V1 in accordance with the specified values. For the second half of the measurements, the pressure relief valve 1V1 should be fully opened and the system pressure varied by means of the pressure relief valve 0V1. The system pressure/flow rate characteristic for the flow control valve can then be plotted.

If the same exercise is carried out using a throttle-type flow control valve, the differences will be readily apparent in the tables of values.

Evaluation

- $p_{z1}$  = Pressure upstream of valve
- $p_{z2}$  = Pressure downstream of valve
- $q_{fcv}$  = Flow rate through flow control valve
- $q_{tv}$  = Flow rate through throttle valve

$p_{z1}$	50 bar	50 bar	50 bar	50 bar	50 bar	50 bar
$p_{z2}$	10 bar	20 bar	30 bar	40 bar	50 bar	50 bar
$q_{shv}$	2 l/min	2 l/min	2 l/min	2 l/min	2 l/min	1.2 l/min
$q_{cv}$	2 l/min	1.8 l/min	1.3 l/min	0.7 l/min	0.1 l/min	

Fluctuating inlet pressure

$p_{z1}$	10 bar	10 bar	10 bar	10 bar	10 bar	10 bar
$p_{z2}$	10 bar	10 bar	10 bar	10 bar	10 bar	10 bar
$q_{cv}$	2 l/min	2 l/min	2 l/min	2 l/min	2 l/min	2 l/min
$q_{qv}$	0.4 l/min	0.8 l/min	1.3 l/min	1.6 l/min	1.3 l/min	0.8 l/min

Flow control valve characteristic

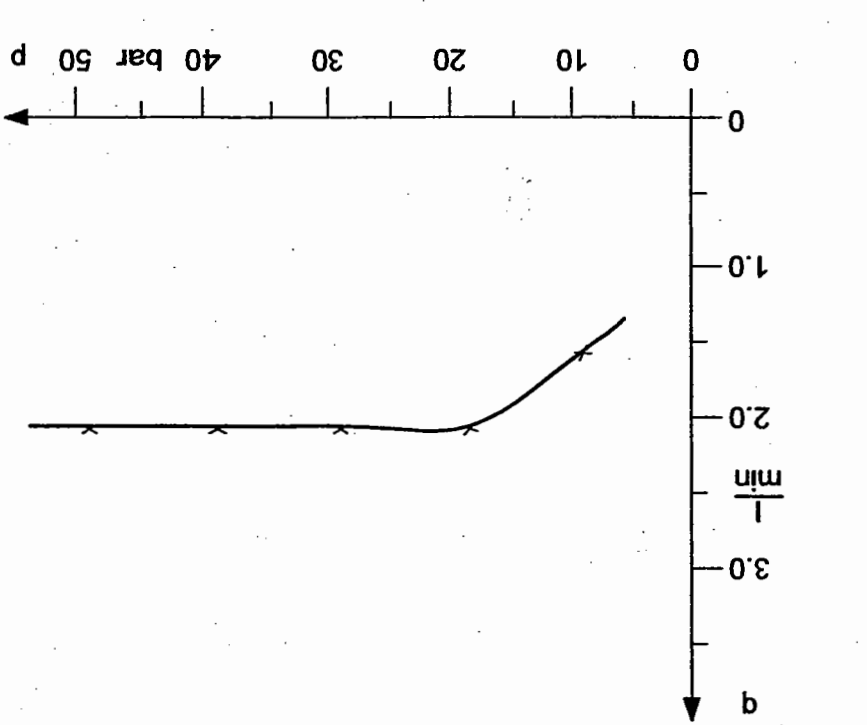

Conclusions

Only the flow control valve offers a suitable means of setting a constant speed with different pressures. In the case of the throttle valve, the flow rate varies as a function of pressure. Reason: In the case of the flow control valve, the built-in pressure compensator keeps the pressure difference constant. This gives a constant flow rate, which can then be adjusted with a throttle valve. Operation of the pressure compensator does, however, require a certain minimum pressure. The throttle valve is a simple restrictor, which produces a flow rate as a function of the pressure difference.

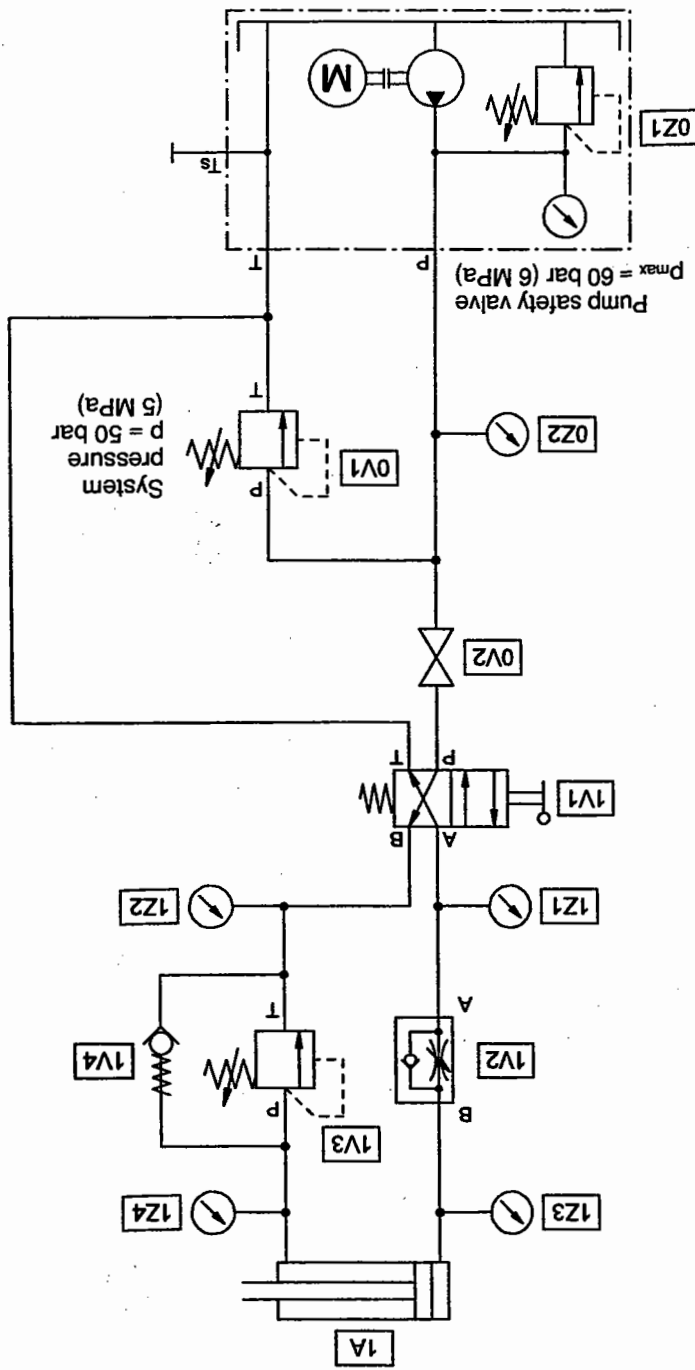

Embossing machine

Practical assembly,  
hydraulic

Components list

Item no.	Qty.	Description
0Z1	1	Hydraulic power pack
0Z2, 1Z1, 1Z2, 1Z3, 1Z4	5	Pressure gauge
0V1, 1V3	2	Pressure relief valve
0V2	1	Shut-off valve
1V1	1	4/2-way valve, manually operated
1V2	1	One-way flow control valve
1A	1	Cylinder, double-acting
1V2	1	Non-return valve
	14	Hose line
	4	Branch tee
	1	Stop-watch

Solution description

Once the circuit has been assembled and checked, close the shut-off valve 0V2 and set a pressure of 50 bar, using the pressure relief valve 0V1. Open the pressure relief valve 1V3 and the shut-off valve.

Now adjust the one-way flow control valve 1V2 in such a way that the piston rod reaches its forward end position in approx. 5 sec. after the 4/2-way valve 1V1 is reversed.

Do not make any further changes to the setting of the one-way flow control valve. The pressure specified in table 1 of 10 bar, as indicated by the pressure gauge 1Z4, can be set only during the advance stroke, using the pressure relief valve 0V1. The pressure  $p_{1Z1}$  should be set by means of the pressure relief valve 0V1 as soon as the 4/2-way valve is reversed and the piston rod has reached its forward end position.

	Fluctuating inlet pressure	Fluctuating outlet pressure
$p_{1z1}$	50 bar	50 bar
$p_{1z2}$	50 bar	50 bar
$p_{1z3}$	40 bar	50 bar
$p_{1z4}$	30 bar	50 bar
$t \rightarrow$	4 s	7 s
$p_{1z1}$	50 bar	50 bar
$p_{1z2}$	9 bar	9 bar
$p_{1z3}$	9 bar	15 bar
$p_{1z4}$	10 bar	20 bar
$t \rightarrow$	4 s	4.5 s
$p_{1z1}$	50 bar	50 bar
$p_{1z2}$	9 bar	22 bar
$p_{1z3}$	9 bar	30 bar
$p_{1z4}$	9 bar	40 bar
$t \rightarrow$	4 s	5 s
$p_{1z1}$	50 bar	50 bar
$p_{1z2}$	9 bar	35 bar
$p_{1z3}$	9 bar	40 bar
$p_{1z4}$	10 bar	50 bar
$t \rightarrow$	4 s	6.5 s
$p_{1z1}$	50 bar	50 bar
$p_{1z2}$	9 bar	28 bar
$p_{1z3}$	9 bar	35 bar
$p_{1z4}$	10 bar	40 bar
$t \rightarrow$	4 s	7 s

Evaluation

- $p_{1z1}$  = Pressure upstream of one-way flow control valve
- $p_{1z2}$  = Pressure downstream of one-way flow control valve
- $p_{1z3}$  = Pressure at counter-holding valve
- $p_{1z4}$  = Pressure at counter-holding valve
- $t \rightarrow$  = Cylinder advance-stroke time

*Conclusions*

In the case of a circuit with a throttle valve, the travel speed falls both as the inlet pressure is reduced and as the counter pressure increases.

In the case of the circuit with a flow control valve (exercise 9), the travel speed remains constant.

Reason: The throttle valve varies only the cross-section of the line through which flow passes. The flow rate produced is dependent on the difference in the pressures upstream and downstream of the restriction. The flow rate through the throttle valve is thus dependent on pressure, in fact on both the supply and load pressures. The flow control valve incorporates a pressure compensator which maintains the internal pressure difference at a constant value. The flow rate is thus not dependent on the supply and load pressures.

Practical assembly,  
hydraulic

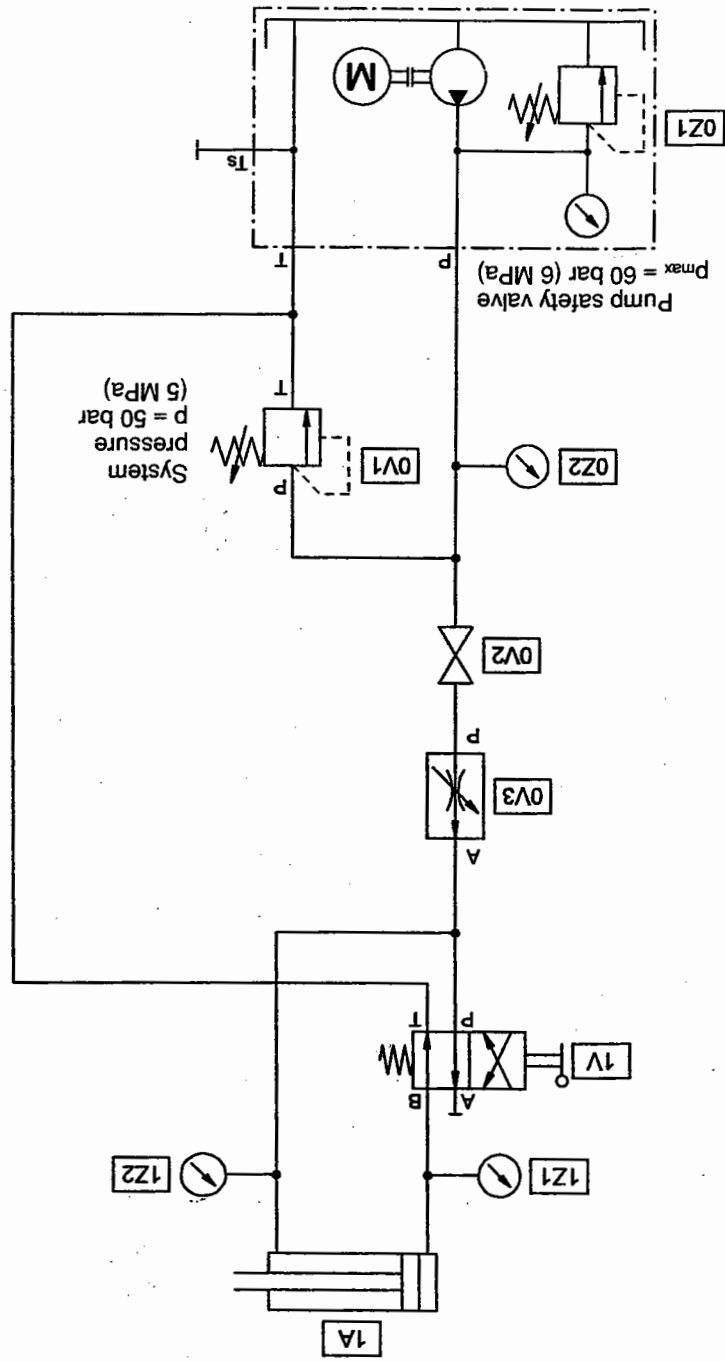

Surface grinding machine

Components list

Item no.	Qty.	Description
0Z1	1	Hydraulic power pack
0Z2, 1Z1, 1Z2	3	Pressure gauge
0V1	1	Pressure relief valve
0V2	1	Shut-off valve
0V3	1	2-way flow control valve
1V	1	4/2-way valve, manually operated
1A	1	Cylinder, double-acting
	7	Hose line
	4	Branch tee
	1	Stop-watch

Solution description

Assemble and check the circuit. Close the shut-off valve 0V2 and the flow control valve 0V3. Now switch on the hydraulic power pack and set a system pressure of 50 bar by means of the pressure relief valve 0V1. Now open the shut-off valve 0V2 and also open the flow control valve until the piston rod advances. The measurements can now be carried out.

Evaluation

$p_{1z1}$  = Pressure on piston side of cylinder  
 $p_{1z2}$  = Pressure on annular piston side of cylinder  
 $p_{0z2}$  = System pressure = 50 bar  
 $t \rightarrow$  = Cylinder advance-stroke time approx. 4 s

Values table

Direction	$p_{1z1}$	$p_{1z2}$	$t$
Advance stroke	3.5 bar	5 bar	4.31 s
Return stroke	0 bar	4.5 bar	6.57 s



Cylinder dimensions:  
 Piston area:  $A_{PN} = 2.0 \text{ cm}^2$   
 Annular piston area:  $A_{PR} = 1.2 \text{ cm}^2$   
 Cylinder stroke:  $s = 0.2 \text{ m}$

Area ratio:  $\alpha = \frac{A_{PN}}{A_{PR}} = \frac{2 \text{ cm}^2}{1.2 \text{ cm}^2} = 1.67 \approx 1.7$

Time ratio:  $\frac{t_{adv}}{t_{rel}} = \frac{4.31 \text{ s}}{6.57 \text{ s}} = 0.656$

Force ratio:  $\frac{F_1}{F_2} = \frac{A_{PN} \cdot p_{z1}}{A_{PR} \cdot p_{z2}} = \frac{2 \text{ cm}^2 \cdot 3.5 \text{ bar}}{1.2 \text{ cm}^2 \cdot 5 \text{ bar}} = 1.2 < \alpha$

Flow rate during advance stroke:

Piston side:

$$q_{PN} = A_{PN} \cdot \frac{t_{adv}}{s} = 2 \text{ cm}^2 \cdot \frac{4.31 \text{ s}}{20 \text{ cm}}$$

$$q_{PN} = 9.28 \frac{\text{cm}^3}{\text{s}} = 557 \frac{\text{cm}^3}{\text{min}} \approx 0.6 \frac{\text{min}}{\text{l}}$$

Annular piston side:

$$q_{PR} = A_{PR} \cdot \frac{t_{adv}}{s} = 1.2 \text{ cm}^2 \cdot \frac{4.31 \text{ s}}{20 \text{ cm}}$$

$$q_{PR} = 5.57 \frac{\text{cm}^3}{\text{s}} = 334 \frac{\text{cm}^3}{\text{min}} \approx 0.3 \frac{\text{min}}{\text{l}}$$

Flow rate during return stroke:

Annular piston side:

$$q_{PR} = A_{PR} \cdot \frac{t_{rel}}{s} = 1.2 \text{ cm}^2 \cdot \frac{6.57 \text{ s}}{20 \text{ cm}}$$

$$q_{PR} = 3.65 \frac{\text{cm}^3}{\text{s}} = 219 \frac{\text{cm}^3}{\text{min}} = 0.2 \frac{\text{min}}{\text{l}} = q_{FCV}$$

*Conclusions*

If the same pressure acts on a larger area ( $A_{PN}$ ), this produces a larger force ( $F_1$ ).

Mathematical proof:

Given

$$p_{1z1} = p_{1z2}$$

and

$$p_{1z1} = \frac{F_1}{A_{PN}} \text{ und } p_{1z2} = \frac{F_2}{A_{PR}}$$

we obtain

$$\frac{F_1}{A_{PR}} = \frac{F_2}{A_{PR}} = \alpha$$

it follows:

$$F_1 = \alpha \cdot F_2$$

Since  $\alpha > 1$ ,  $F_1 > F_2$ , and the cylinder advances.

The lower travel pressure  $p_{1z1}$  acts on the larger area  $A_{PN}$ , producing a greater force  $F_1$ . Only when the ratio of travel pressure to back pressure becomes equal to the area ratio  $\alpha$  is an equilibrium of forces achieved, causing the piston to stop.

Mathematical proof:

$$\frac{F_1}{A_{PN} \cdot p_{1z1}} = \frac{F_2}{A_{PR} \cdot p_{1z2}}$$

Für

$$F_1 = F_2$$

gilt

$$\frac{p_{1z2}}{A_{PN}} = \frac{p_{1z1}}{A_{PR}} = \alpha$$

As long as  $\frac{p_{1z2}}{A_{PN}} < \alpha$ , the piston will advance.

With an area ratio of  $\alpha = 2$ , the advance-stroke and return-stroke speeds are the same.  
 Reason: The flow rate required on the piston side is double that necessary on the piston rod side. During the advance stroke, this flow rate is supplied from the pump and the annular piston side. During the return stroke, only supply from the pump is available. The return-stroke speed is produced by this. The advance-stroke and return-stroke speeds can be the same only when the area ratio  $\alpha = 2$ .

System	Simple cylinder control circuit	Differential circuit
1. Advance-stroke speed $v_{adv}$	Adjustable on FCV $\approx q_{fcv}$	Greater than set on FCV $> q_{fcv}$
2. Return-stroke speed $v_{ret}$	Greater than advance-stroke speed $> v_{adv}$	Less than advance stroke speed $< v_{adv}$ (with $\alpha < 2$ )
3. Advance-stroke time $t_{adv}$	Adjustable on FCV $\approx q_{fcv}$	Less than set on FCV $< q_{fcv}$
4. Return-stroke time $t_{ret}$	Less than advance-stroke time $< t_{adv}$	Greater than advance-stroke time $> t_{adv}$ (with $\alpha < 2$ )

General comparison

A comparison of a simple cylinder control circuit and a differential circuit reveals the following differences:

$$F = F_1 - F_2 = (A_{pN} \cdot p_{1z1}) - (A_{pR} \cdot p_{1z2})$$

$$F = (2 \text{ cm}^2 \cdot 3.5 \text{ bar}) - (1.2 \text{ cm}^2 \cdot 5 \text{ bar})$$

$$F = (7 \text{ kp} - 6 \text{ kp}) = 1 \text{ kp} = 10 \text{ N}$$

The available cylinder force is:

Simple cylinder control circuit and differential circuit

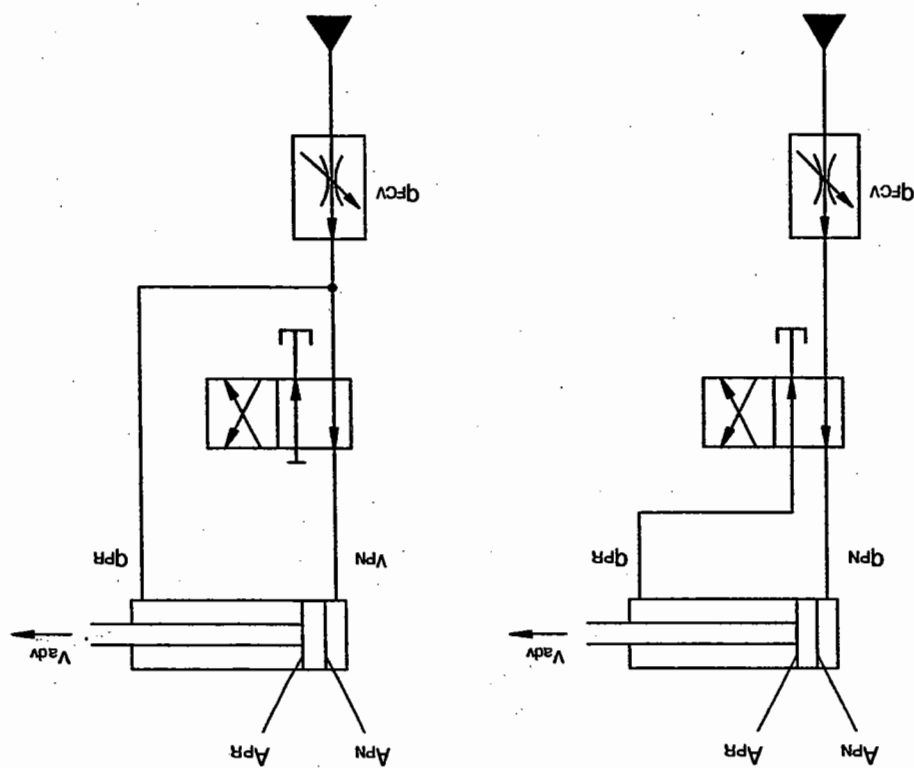

Below is the mathematical proof of this:

Basic equations:

$$\alpha = \frac{A_{pN}}{A_{pR}}$$

Speed:

$$v = \frac{A}{q}$$

Travel time:

$$t = \frac{V}{v}$$

1. Advance-stroke speed

Simple cylinder control circuit:

$$V_{adv} = \frac{q_{PN}}{A_{PN}} = \frac{q_{FCV}}{A_{PN}}$$

With differential circuit:

$$V_{adv} = \frac{q_{PN}}{A_{PN}}$$

Flow rate on piston side:

$$q_{PN} = q_{FCV} + q_{PR}$$

Given

$$\frac{q_{PN}}{A_{PN}} = \frac{q_{PR}}{A_{PR}} = \alpha$$

we obtain:

$$q_{PR} = \frac{1}{\alpha} \cdot q_{PN}$$

It follows:

$$q_{PN} = q_{FCV} + \frac{1}{\alpha} \cdot q_{PN}$$

$$q_{PN} \cdot \left(1 - \frac{1}{\alpha}\right) = q_{FCV}$$

$$q_{PN} \cdot \frac{\alpha - 1}{\alpha} = q_{FCV}$$

$$q_{PN} = \frac{\alpha}{\alpha - 1} \cdot q_{FCV}$$

The advance-stroke speed with a differential circuit is thus:

$$V_{adv} = \frac{q_{FCV}}{\alpha} = \frac{\alpha - 1}{\alpha} \cdot \frac{q_{FCV}}{A_{PN}}$$

For  $\alpha = 2$

$$V_{adv} = 2 \cdot \frac{q_{FCV}}{A_{PN}}$$

and is thus twice as high as with the simple cylinder control circuit.

## 2. Return-stroke speed

Simple cylinder control circuit:

$$V_{ret} = \frac{q_{PR}}{A_{PR}} = \frac{q_{FCV}}{q_{FCV}} = \alpha \cdot \frac{A_{PN}}{q_{FCV}}$$

$$V_{ret} = \alpha \cdot V_{adv}$$

Since  $\alpha > 1$ ,

$$V_{ret} > V_{adv}$$

With differential circuit:

$$V_{ret} = \frac{q_{PR}}{q_{FCV}} = \frac{A_{PR}}{q_{FCV}} = \alpha \cdot \frac{A_{PN}}{q_{FCV}}$$

$$\frac{V_{ret}}{V_{adv}} = \frac{\alpha \cdot \frac{A_{PN}}{q_{FCV}}}{\frac{\alpha - 1}{\alpha} \frac{q_{FCV}}{A_{PN}}} = \alpha - 1$$

$$V_{ret} = (\alpha - 1) \cdot V_{adv}$$

For  $\alpha = 2$ ,

$$V_{ret} = V_{adv}$$

3. Advance-stroke time

In general::

$$t = \frac{s}{v}$$

Simple cylinder control circuit::

$$t_{adv} = \frac{s}{A_{pn} \cdot \alpha} = \frac{q_{FCV}}{A_{pn} \cdot \alpha}$$

With differential circuit::

$$t_{adv} = \frac{s}{\alpha \cdot \frac{q_{FCV}}{A_{pn} \cdot (\alpha - 1)}} = \frac{\alpha - 1}{\alpha} \cdot \frac{q_{FCV}}{A_{pn} \cdot \alpha}$$

With  $\alpha = 2$ ,

$$t_{adv} = \frac{1}{2} \cdot \frac{q_{FCV}}{A_{pn} \cdot \alpha}$$

4. Return-stroke time

Simple cylinder control circuit:

$$t_{ret} = \frac{s}{A_{pn} \cdot \alpha} = \frac{q_{FCV}}{A_{pn} \cdot \alpha}$$

With differential circuit::

$$t_{ret} = \frac{s}{\alpha \cdot \frac{q_{FCV}}{A_{pn} \cdot (\alpha - 1)}} = \frac{\alpha - 1}{\alpha} \cdot \frac{q_{FCV}}{A_{pn} \cdot \alpha}$$

$$\frac{t_{ret}}{t_{adv}} = \frac{A_{pn} \cdot \alpha}{\alpha \cdot \frac{q_{FCV}}{A_{pn} \cdot (\alpha - 1)}} = \frac{\alpha - 1}{\alpha} \cdot \frac{A_{pn} \cdot \alpha}{q_{FCV}}$$

$$\frac{t_{ret}}{t_{adv}} = \frac{\alpha - 1}{1}$$

With  $\alpha = 2$ ,

$$t_{ret} = t_{adv}$$

Mathematical comparison

System	1. Advance-stroke speed $v_{adv}$	2. Return-stroke speed $v_{ret}$	3. Advance-stroke time $t_{adv}$	4. Return-stroke time $t_{ret}$
Simple cylinder control circuit	$\frac{q_{FCV}}{A_{PN}}$	$\alpha \cdot v_{adv}$	$\frac{A_{PN} \cdot s}{q_{FCV}}$	$\frac{1}{\alpha} \cdot t_{adv}$
Differential circuit	$\frac{\alpha}{q_{FCV}} \cdot \frac{A_{PN}}{\alpha - 1}$	$(\alpha - 1) \cdot v_{adv}$	$\frac{\alpha - 1}{\alpha} \cdot \frac{A_{PN} \cdot s}{q_{FCV}}$	$\frac{1}{\alpha - 1} \cdot t_{adv}$

The evaluation can thus be expressed as follows:

Alternative solutions giving identical advance-stroke and return-stroke speeds:

Differential circuit with 4/3-way valve with special mid-position

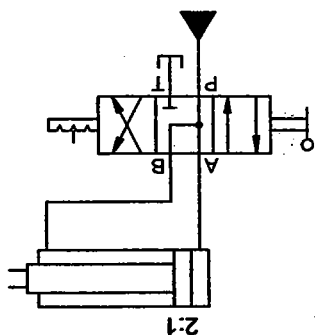

Equal-speed cylinder controlled by 4/2-way valve

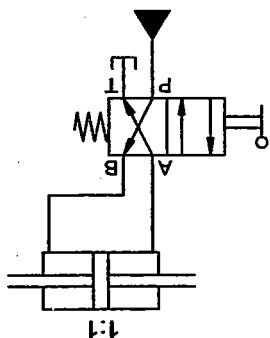



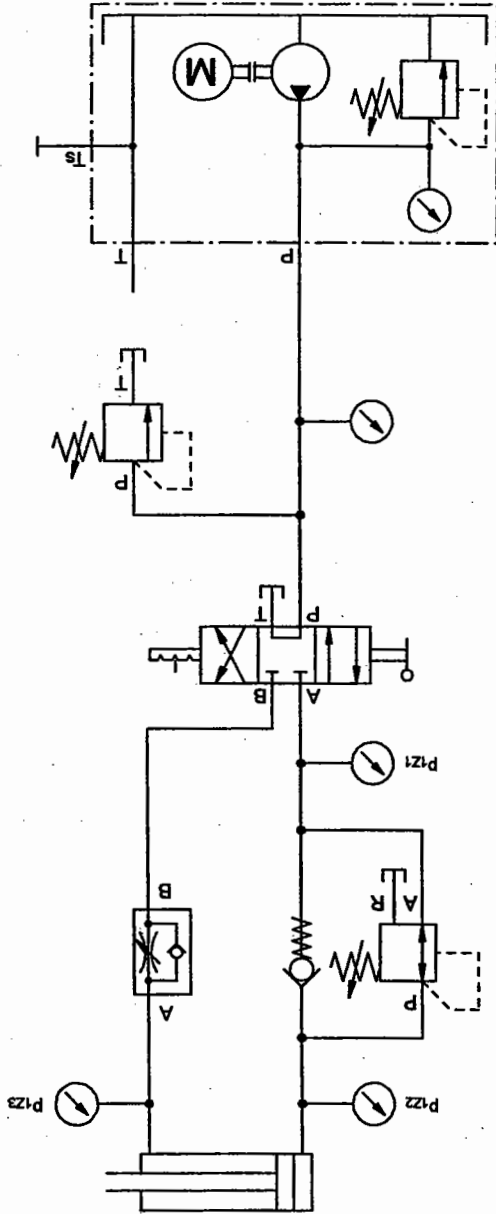

Drilling machine

Circuit diagram, hydraulic

Practical assembly,  
hydraulic

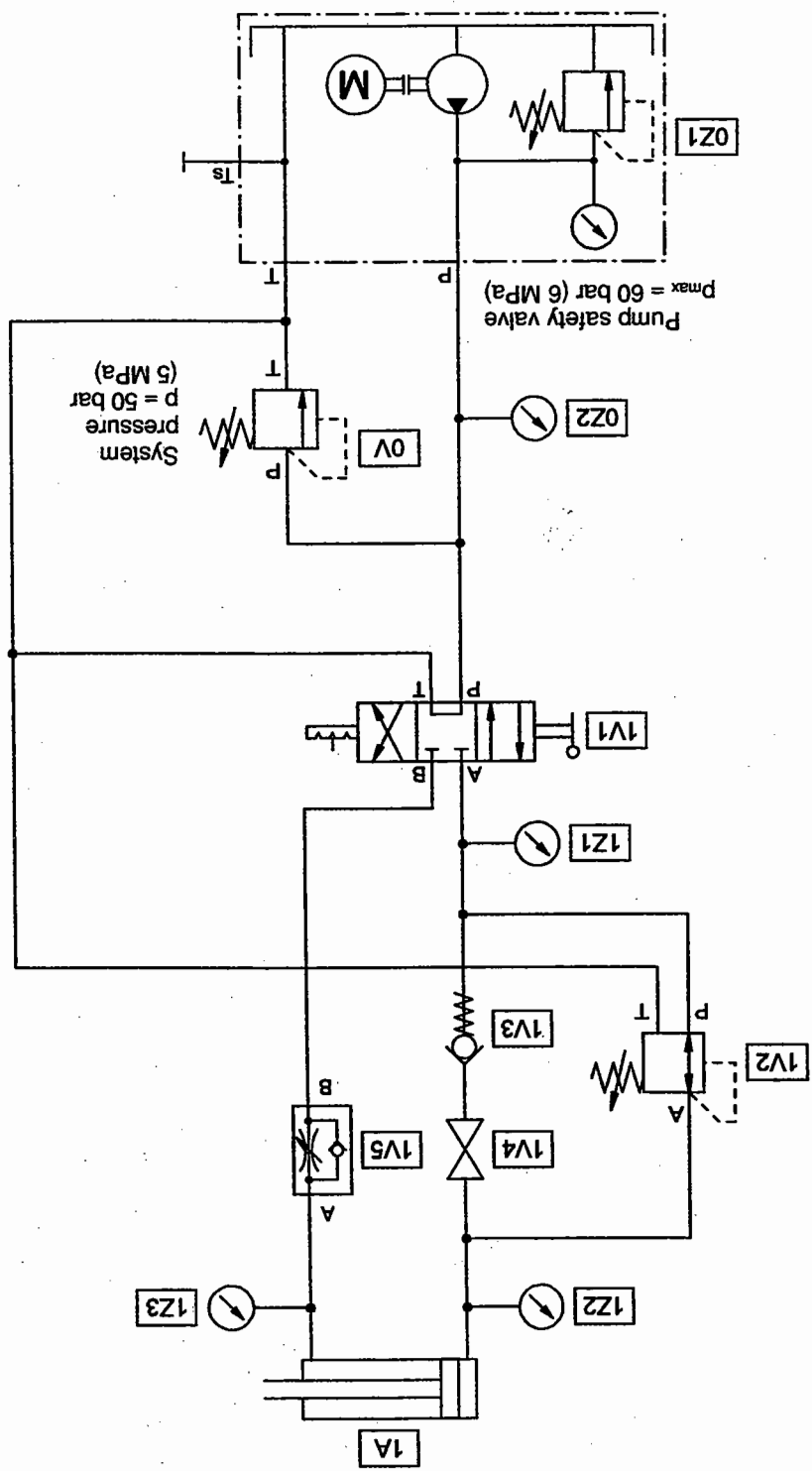

Item no.	Qty.	Description
0Z1	1	Hydraulic power pack
0Z2, 1Z1, 1Z2, 1Z3	4	Pressure gauge
0V	1	Pressure relief valve
1V1	1	4/3-way valve, manually operated
1V2	1	Pressure regulator
1V3	1	Non-return valve
1V4	1	Shut-off valve
1A	1	Cylinder, double-acting
1V5	1	One-way flowcontrol valve
	15	Hose line
	5	Branch tee

Components list

*Solution description*

In the first task in the exercise, the travel pressures are measured; the inlet pressure can be set to 15 bar (as shown on  $p_{12}$ ) only after the piston has reached its forward end position or is opposed by a resistance. This is demonstrated by task 2 (piston in forward end position). This task also shows that the pressure regulator maintains a pressure of 15 bar even without through-flow.

The valves 1V3 and 1V4 provide a bypass of the pressure regulator to allow a faster return stroke to be achieved.

If the advance stroke is opposed by a resistance, as in task 3, a flow pressure of only 12 - 15 bar is achieved, despite the system pressure of 50 bar. By closing the throttle valve 1V5, it is possible to increase the counter pressure until the pressure gauge  $p_{12}$  shows 15 bar; the piston will then stop, i.e. the pressure regulator will close.

In task 5, it is demonstrated that increased counter pressure during the return stroke causes the valve to the tank to open, resulting in only the set pressure of 15 bar being attained. The piston can be pushed into the retracted end position. With the piston in this position, as in task 6, the 15 bar pressure is initially maintained. Due to internal leakage within the valve, the pressure then falls below 15 bar, causing the pressure regulator to switch from A - T to P - A. As no pump delivery is reaching the line to the pressure regulator via the 4/3-way valve, the pressure falls to 0 bar.

In practice, a pressure relief valve with bypass must be used in place of the one-way flow control valve 1V5. This prevents the high pressures which would arise upstream of the one-way flow control valve due to pressure intensification during the advance stroke of the piston. A one-way flow control valve has been used in this case to simplify the circuit configuration. Excessive pressures cannot arise in this case due to the fact that the system is being operated with reduced pressure.

Cases of examination			
1. Return stroke	4 bar	7 bar	16 bar
2. End position	0 bar	0 bar	50 bar
3. Return stroke with counter pressure	6 bar	10 bar	18 bar
4. End position	0 bar	0 bar	50 bar
5. Return stroke with pressure regulator	0 bar	26 bar	46 bar
6. End position	0 bar	0 bar	50 bar

Return stroke

Cases of examination			
1. Advance stroke	5 bar	2 bar	1 bar
2. End position	50 bar	15 bar	0 bar
3. Advance stroke with counter pressure	49 bar	13 bar	20 bar
4. End position	50 bar	16 bar	0 bar
5. Advance stroke with pressure regulator	49 bar	14 bar	20 bar
6. End position	50 bar	16 bar	0 bar

Advance stroke

- Cases of examination:
1. Piston advance stroke
  2. Piston advanced to end position with setting  $p_{122} = 15$  bar.
  3. Piston advance stroke with counter pressure setting,  $p_{123} = 20$  bar.
  4. Piston advanced to end position
  5. Piston advance stroke with shut-off valve closed
  6. Piston advanced to end position with shut-off valve closed

Measured are:

- $p_{121}$  = Pressure upstream of pressure regulator
- $p_{122}$  = Pressure upstream of cylinder
- $p_{123}$  = Pressure downstream of cylinder

Evaluation

*Conclusions*

Pressure regulators are used in cases when a secondary circuit with a constant but lower pressure is required in addition to a primary circuit. Note that increased pressures occur which act on port A of the pressure regulator. These pressures must be discharged to the tank.

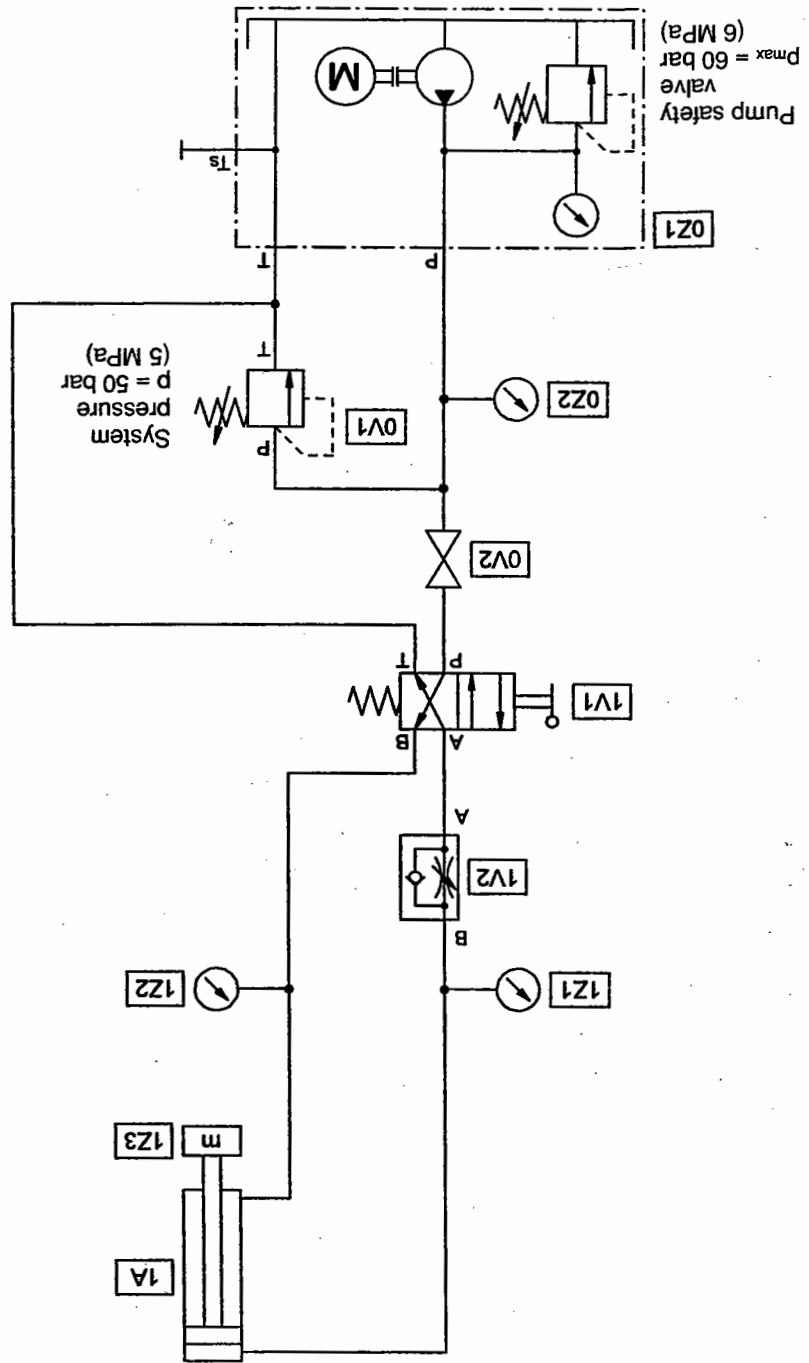

Bulkhead door

Circuit diagram, hydraulic, without counter-holding

Practical assembly,  
hydraulic,  
with counter-holding

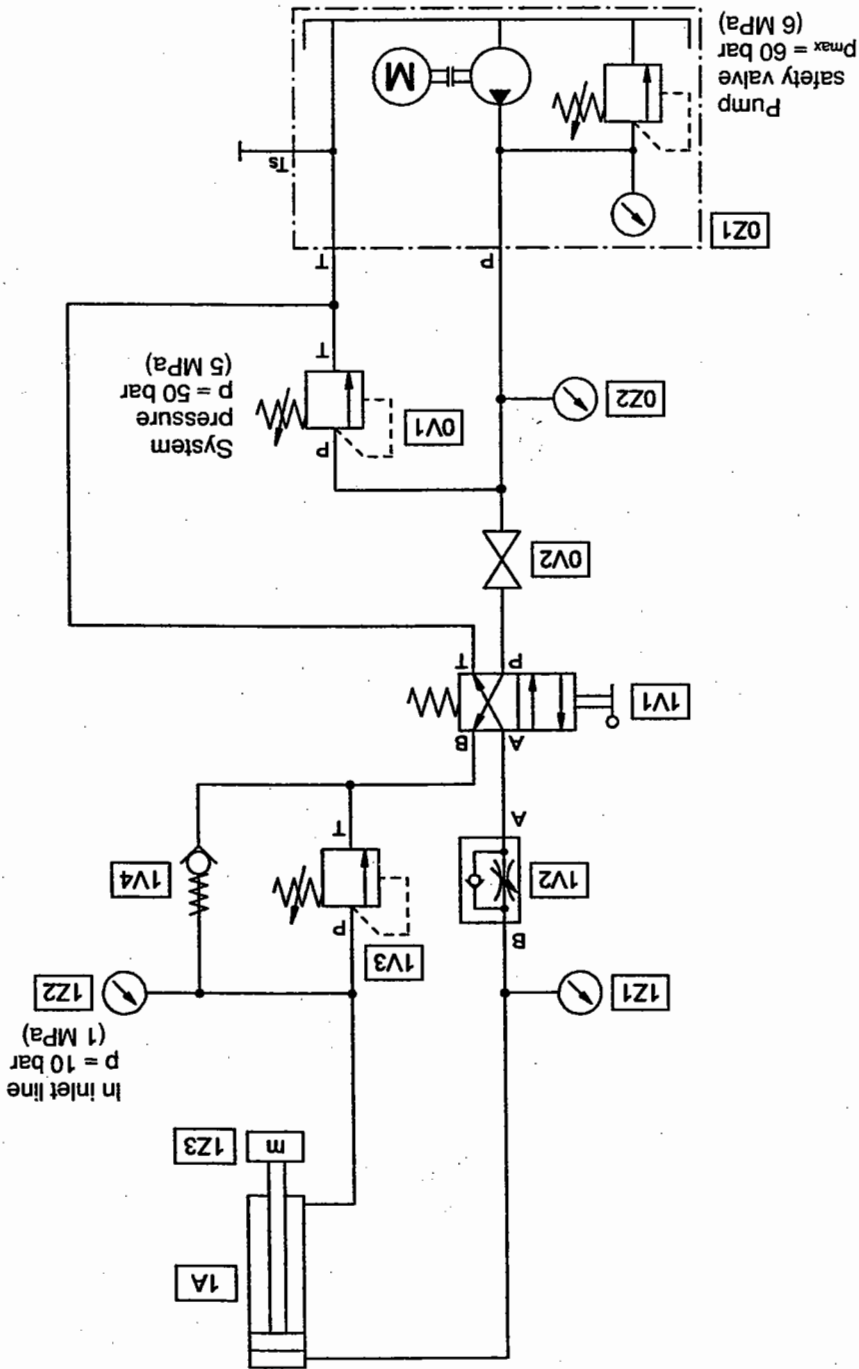



Components list

Item no.	Qty.	Description
0Z1	1	Hydraulic power pack
0Z2, 1Z1, 1Z2	3	Pressure gauge
0V1, 1V3	2	Pressure relief valve
0V2	1	Shut-off valve
1V1	1	4/2-way valve
1V2	1	One-way flow control valve
1A	1	Cylinder, double-acting
1Z3	1	Loading weight
1V4	1	Non-return valve
	12	Hose line
	4	Branch tee
	1	Stop-watch

Solution description

Assemble and check the circuit. Mount the cylinder 1A on the profile in such a way that it can advance downwards. First close the shut-off valve 0V2. Switch on the hydraulic power pack and then use the pressure relief valve 0V1 to set a system pressure of 50 bar. Open the shut-off valve and adjust the pressure relief valve 1V2 in such a way that the piston rod advances in approx. 5 sec. The throttle valve setting should be retained while manipulating the circuit using the weight 1Z3, with counter-holding provided by the pressure relief valve 1V3. For the return stroke, a non-return valve 1V4 is required as a bypass for the pressure relief valve. After the measurements have been completed, first remove the weight and then retract the cylinder. Now depressurise the circuit by closing the shut-off valve and then opening the pressure relief valve 1V3. Dismantle the circuit only when the pressure has fallen to zero, as shown by the pressure gauge 1Z2.

**Evaluation**

Measure the following:

- $t \rightarrow$  = Cylinder advance-stroke time
- $p_{1z1}$  = Cylinder travel pressure
- $p_{1z2}$  = Cylinder back pressure
- $p_{0z2}$  = System pressure

Values table

With load and counter-holding	$p_{0z2}$	$p_{1z1}$	$p_{1z2}$	$t \rightarrow$
Without load with counter-holding	50 bar	0 bar	0 bar	5.0 s
With load without counter-holding	50 bar	0 bar	0 bar	0.8 s
With load and counter-holding	50 bar	2 bar	10 bar	4.6 s
Without load with counter-holding	50 bar	7 bar	10 bar	5.3 s

**Conclusions**

The travel time becomes shorter as the load increases.

Reason: The piston is pulled out by the load. Without counter-holding, the movement is uncontrolled and jerky. A constant advance-stroke speed is obtained only with counter-holding. The generation of a counter pressure clamps the piston hydraulically. The travel and back pressures remain constant, which means that the travel speed also remains constant.

A circuit with counter-holding is advisable both with and without a load. It is also possible to adjust the counter-holding to suit the load.

Ferry loading ramp

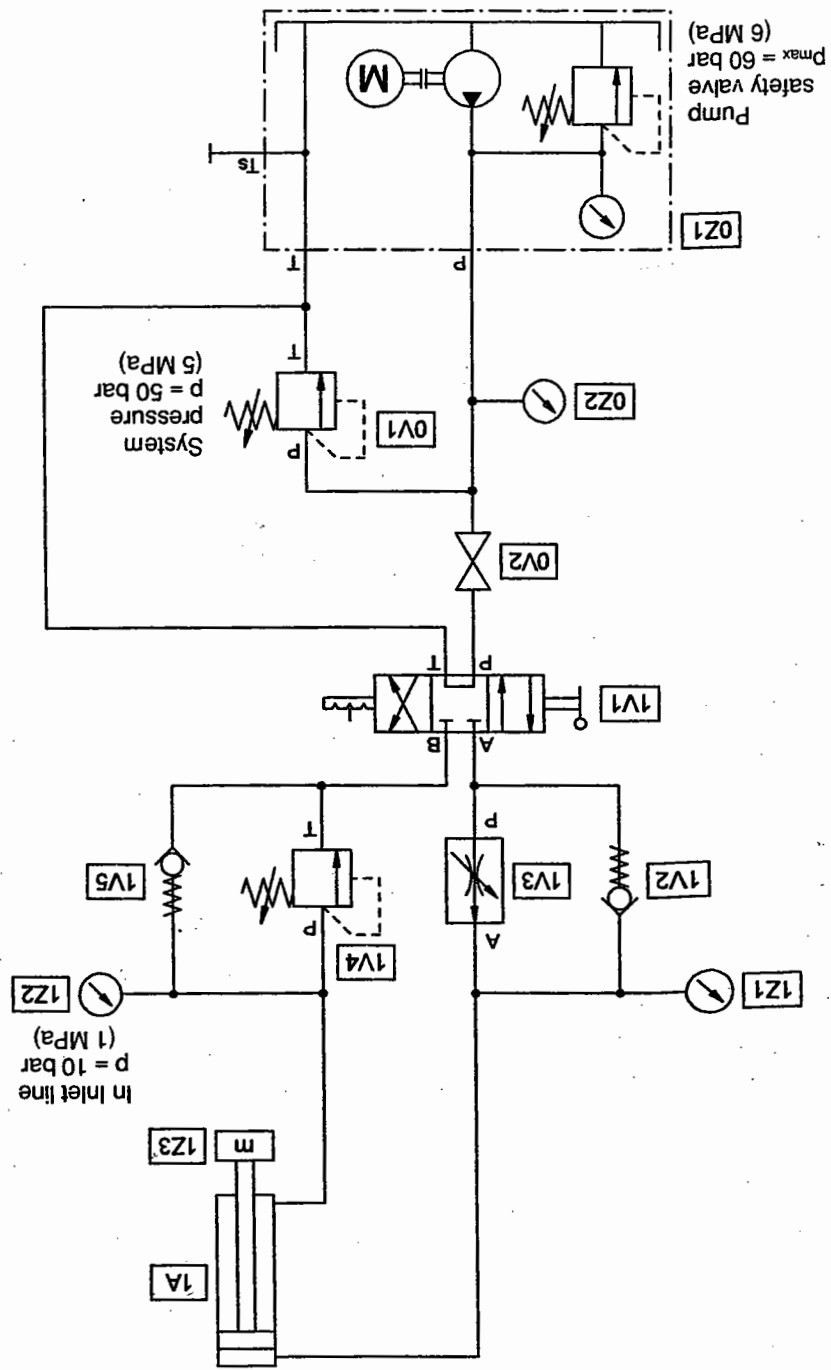

Circuit diagram, hydraulic, with counter-holding and flow control valve in inlet line

Practical assembly,  
hydraulic,  
with flow control valve  
in outlet line

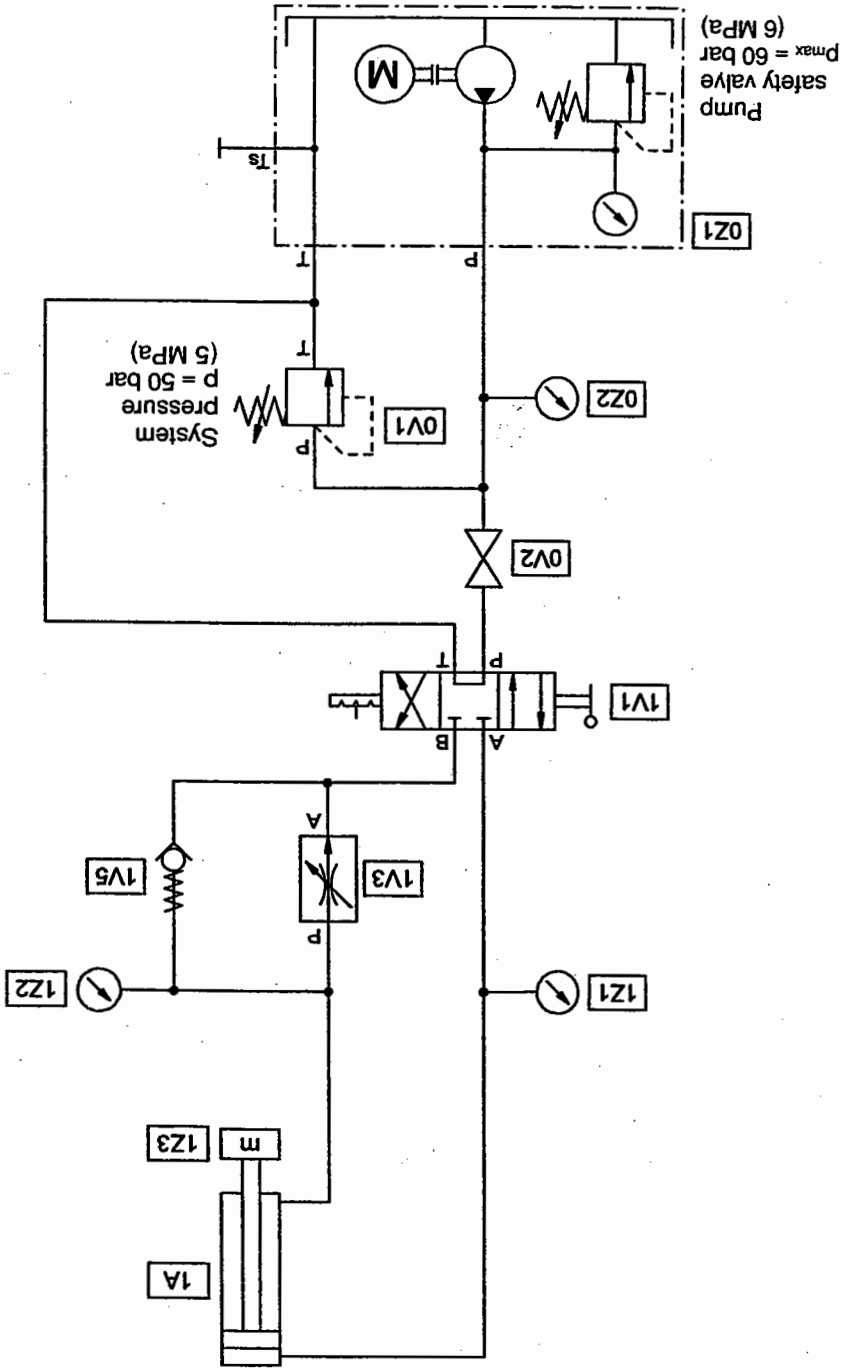

Assemble and check the circuit. Mount the cylinder 1A on the profile plate in such a way that it can advance downwards. First close the shut-off valve 0V2. Switch on the hydraulic power pack and then use the pressure relief valve 0V1 to set a system pressure of 50 bar. Open the shut-off valve and adjust the pressure relief valve 1V3 in such a way that the piston rod advances in approx. 5 sec. The flow control valve setting should be retained throughout the series of measurements. Only the circuit should be modified. Dismantle the circuit only when the pressure has fallen to zero, as shown by the pressure gauge 1Z2.

*Solution description*

Item no.	Qty.	Description
0Z1	1	Hydraulic power pack
0Z2, 1Z1, 1Z2	3	Pressure gauge
0V1, 1V4	2	Pressure relief valve
0V2	1	Shut-off valve
1V1	1	4/3-way valve
1V3	1	Flow control valve
1V2, 1V5	2	Non-return valve
1A	1	Cylinder, double-acting
1Z3	1	Loading weight
	13	Hose line
	4	Branch tee
	1	Stop-watch

*Components list*

Evaluation

Measure the following:

- $t \leftarrow$  = Cylinder advance-stroke time
- $p_{1z1}$  = Cylinder travel pressure
- $p_{1z2}$  = Cylinder back pressure
- $p_{0z2}$  = System pressure

Flow control valve in inlet line	Without load and counter-holding	$p_{0z2}$	$p_{1z1}$	$p_{1z2}$	$t \leftarrow$
Without load without counter-holding	50 bar	0 bar	0 bar	0 bar	5 s
With load without counter-holding	50 bar	0 bar	0 bar	0 bar	0.6 s
Without load and counter-holding	50 bar	3 bar	8 bar	10 bar	5 s
With load with counter-holding	50 bar	8 bar	10 bar	10 bar	5 s

Flow control valve in outlet line	Load	$p_{0z2}$	$p_{1z1}$	$p_{1z2}$	$t \leftarrow$
Without load	50 bar	50 bar	48 bar	77 bar	5 s
With load	50 bar	50 bar	48 bar	84 bar	3.1 s

Conclusions

Without counter-holding, the piston rod is pulled out by the load. It advances jerkily. With counter-holding, the same speed is achieved with and without a load. If, however, the flow control valve is installed in the outlet line to provide counter-holding, very high pressures will occur on the outlet side. This is often unacceptable in practice.

A suitable circuit is thus one with a flow control valve in the inlet line and counter-holding by means of a pressure relief valve in the outlet line.

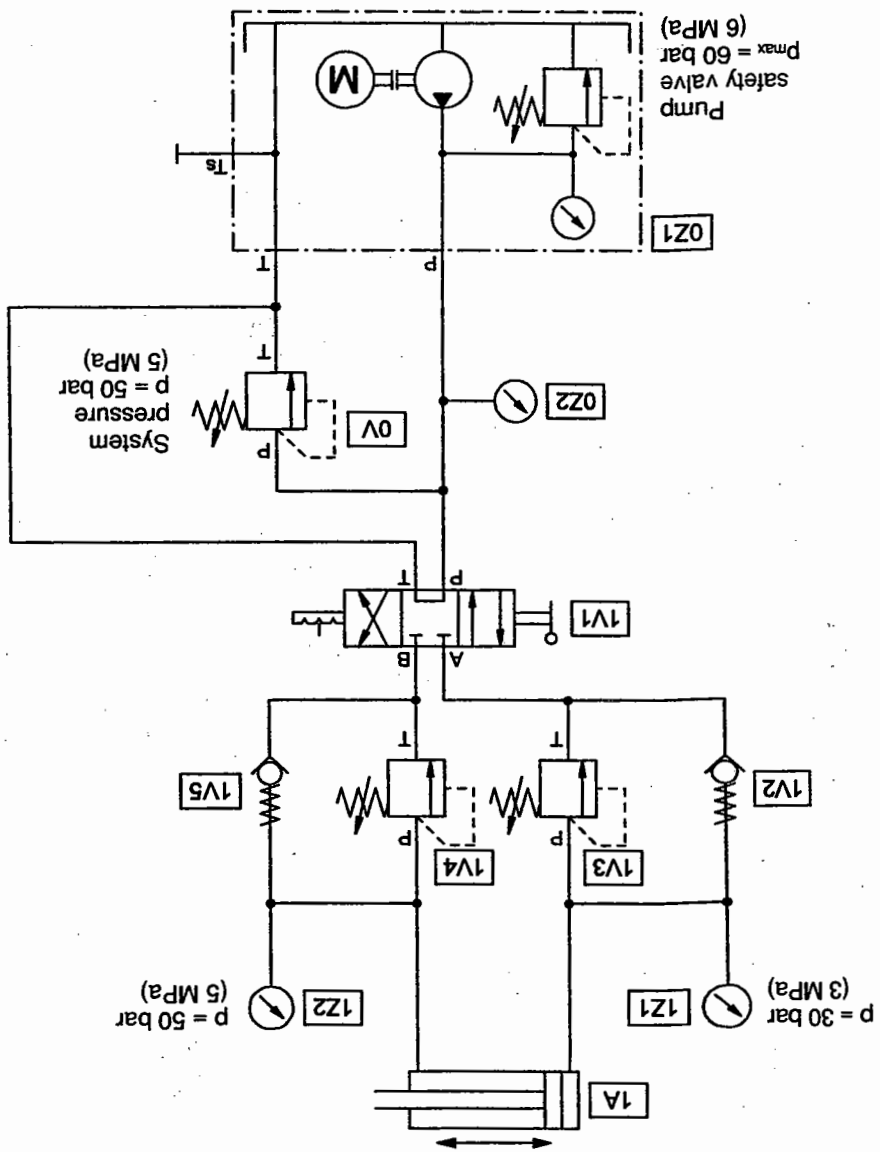

Skip handling

Practical assembly,  
hydraulic

Components list

Item no.	Qty.	Description
0Z1	1	Hydraulic power pack
0Z2, 1Z1, 1Z2	3	Pressure gauge
0V, 1V3, 1V4	3	Pressure relief valve
1V1	1	4/3-way valve, manually operated
1V2, 1V5	2	Non-return valve
1A	1	Cylinder, double-acting
	10	Hose line
	4	Branch tee

Solution description

Assemble the control circuit in accordance with the circuit diagram. Ensure that the non-return valves are installed correctly. Open the pressure relief valves fully. If a sufficient number of pressure relief valves are not available, the system pressure can also be set on the pressure relief valve of the hydraulic power pack.

Check the circuit and then switch on the hydraulic power pack. Now set the system pressure to 50 bar. When the directional control valve 1V1 is actuated, the cylinder advances and retracts at maximum speed. The travel motion can be slowed down by closing the two pressure relief valves 1V3 and 1V4. Adjustment is carried out using the pressure relief valve in the outlet line in each case. The non-return valves 1V2 and 1V5 are used to bypass the pressure relief valves fitted in each inlet line. The counter-holding pressures are shown on the pressure gauges 1Z1 and 1Z2.

If the non-return valves are installed incorrectly, the travel speed will not change even when the pressure relief valves are closed. With the pressure relief valves fully closed, the cylinder will no longer retract due to the pressure intensification effect present.



Before the circuit is dismantled, the pressure relief valves must once again be fully opened to ensure that no pressure is trapped.



*Conclusions* Hydraulic clamping on both sides is provided by two counter-holding circuits with pressure relief valves. A non-return valve is required as a bypass in each direction. Take account of the cylinder area ratio when setting the pressure.

*Remark* In practice, skip handling is controlled using proportional valves. Dynamic adjustment of the proportional valves allows better control of fast and slow travel motions.



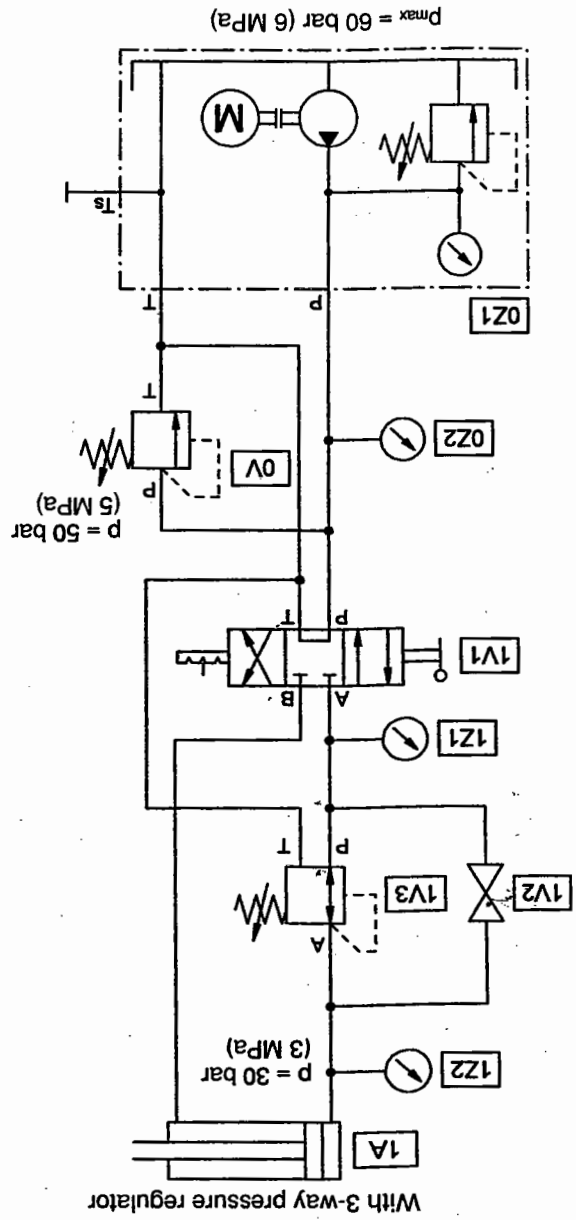
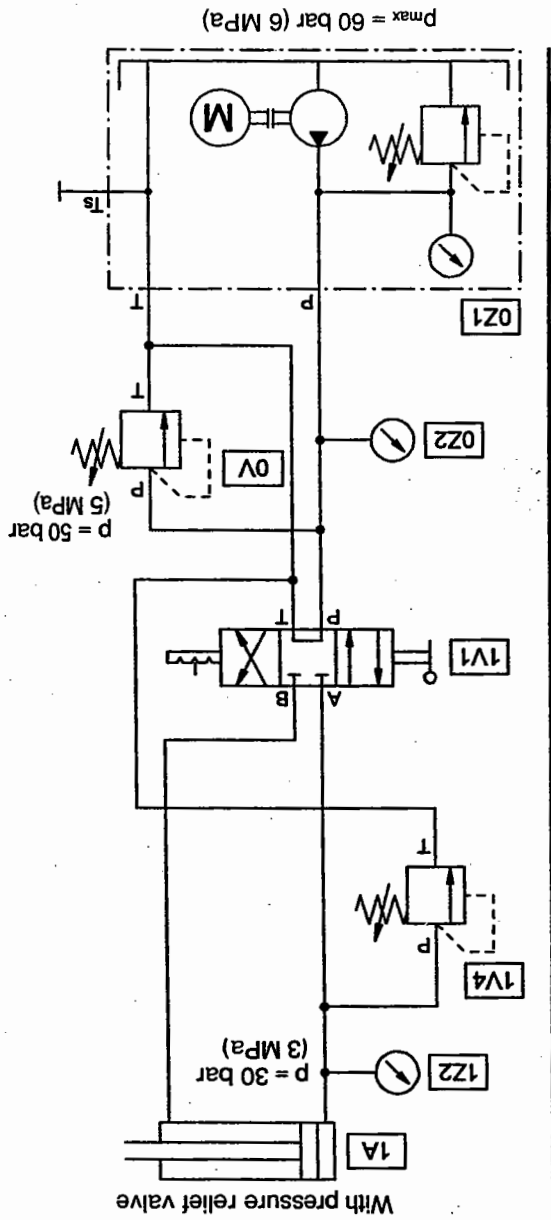

Practical assembly,  
hydraulic

Bonding press

Components list

Item no.	Qty.	Description
0Z1	1	Hydraulic power pack
0Z2, 1Z1, 1Z2	3	Pressure gauge
0V, 1V4	2	Pressure relief valve
1V1	1	4/3-way valve, manually operated
1V2	1	Shut-off valve
1V2	1	Pressure regulator
1A	1	Cylinder, double-acting
	7	Hose line
	5	Branch tee

Solution description

In the case of the circuit with the pressure regulator, the shut-off valve must be opened to retract the piston rod. Due to the pressure intensification effect, the system pressure of 50 bar is not sufficient to open the pressure regulator from A to T.

Conclusions

If a pressure relief valve is fitted in the bypass, the overall system pressure will fall to 30 bar during the advance stroke. If a pressure regulator is used, the system pressure of 50 bar is maintained, and only the cylinder is supplied with the reduced pressure of 30 bar. This allows further actuators to be supplied with full system pressure by the same hydraulic power pack. Check, however, that the pump delivery is sufficient for this. The pressure relief valve gives an advantage in this application, since, in the case of long standstill periods with the directional control valve actuated, the pump need only develop the set pressure of 30 bar.

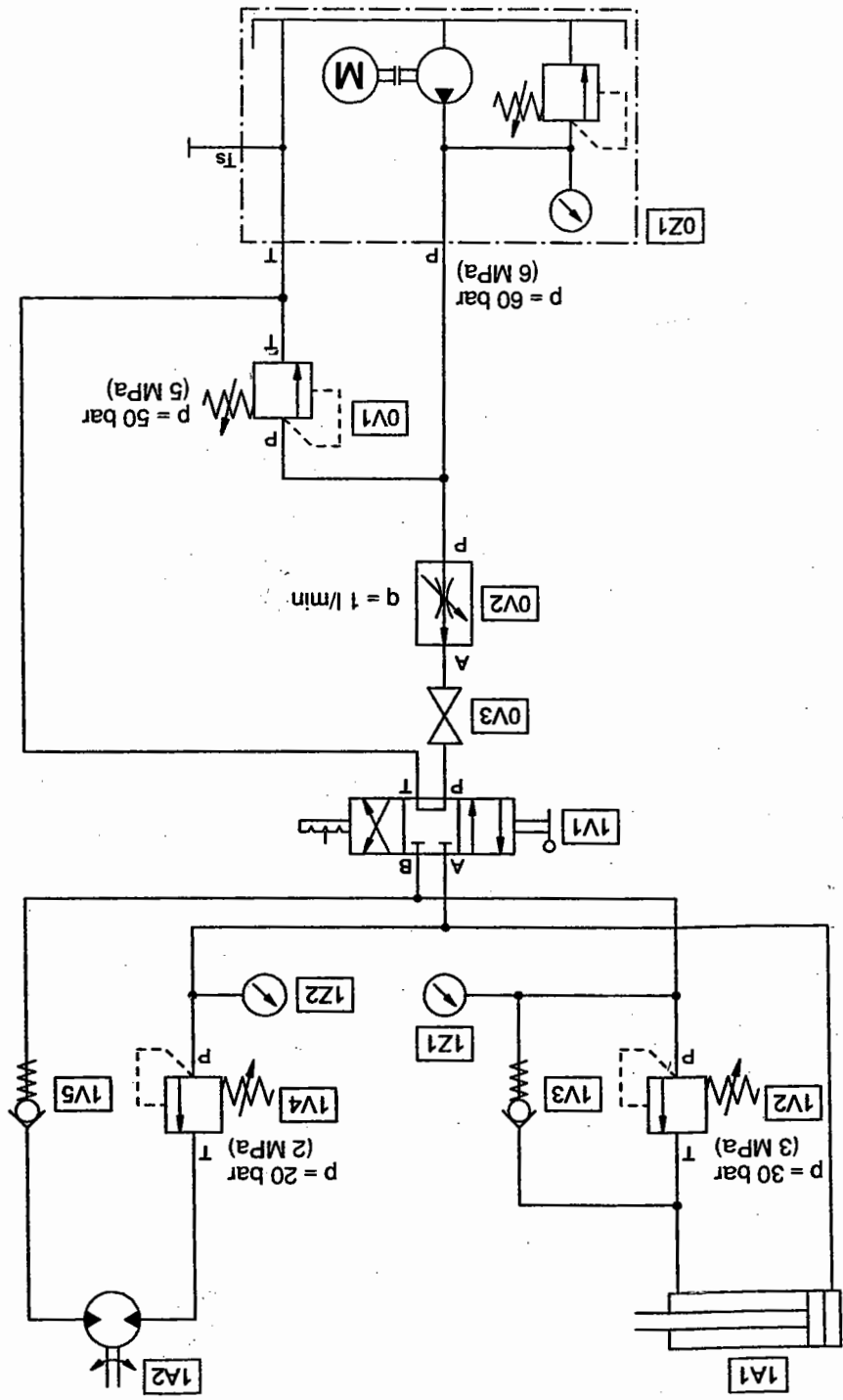

Assembly device

Practical assembly,  
hydraulic

Displacement-step diagram

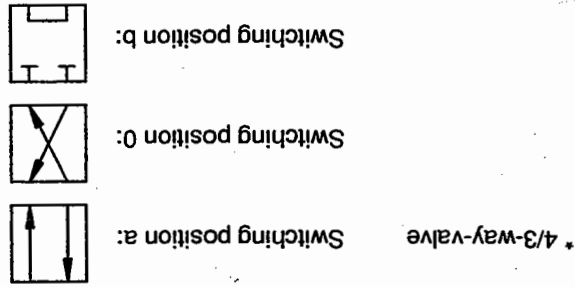
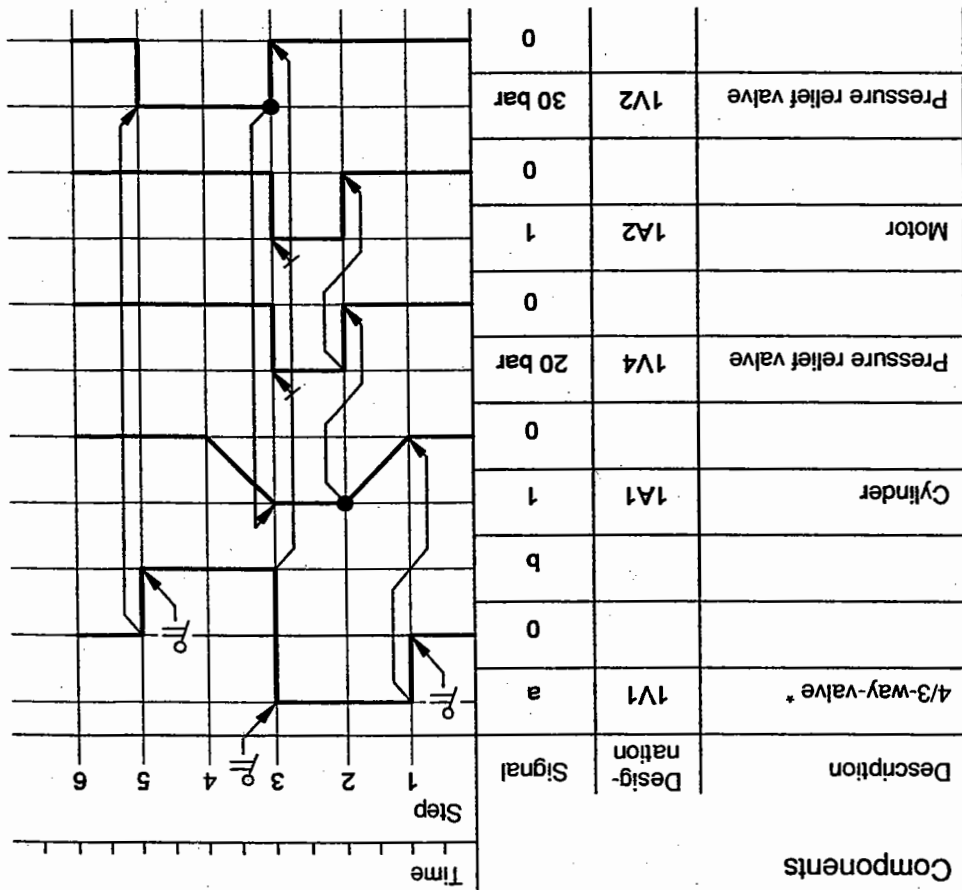

Once the circuit has been assembled and checked, switch on the hydraulic power pack. The shut-off valve should be closed at this time. The system pressure of 50 bar can now be set on the pressure relief valve 0V1. The two other pressure relief valves should be closed. When the 4/3-way valve is actuated, fluid will first flow to cylinder 1A1, and the piston of this will advance. Motor 1A2 will begin to rotate only when the pressure relief valve 1V4 is opened. The return stroke is initiated by reversing the 4/3-way valve. The motor will then stop. A pressure will build up at the pressure relief valve 1V2. Cylinder 1A1 will retract when the pressure relief valve 1V2 is opened.

Before assembling the circuit, set the flow control valve to a flow rate of 1 l/min. When assembling the circuit, ensure that the non-return valves are installed correctly, since otherwise pressure may become trapped. If a sufficient number of pressure relief valves is not available, the system pressure can be set on the pressure relief valve of the hydraulic power pack.

*Solution description*

Item no.	Qty.	Description
0Z1	1	Hydraulic power pack
0V1, 1V2, 1V4	3	Pressure relief valve
0V2	1	Flow control valve
0V3	1	Shut-off valve
1V1	1	4/3-way valve, manually operated
1A1	1	Cylinder, double-acting
1A2	1	Hydromotor
1V3, 1V5	2	Non-return valve
1Z1, 1Z2	2	Pressure gauge
	16	Hose line
	7	Branch tee
	1	Flow sensor

*Components list*

*Conclusions* The most important steps in commissioning are as follows:

1. Presetting of flow rate
2. Assembly of circuit
3. Closing the pressure relief valves
4. Checking the circuit
5. Switching on the hydraulic power pack
6. Adjusting the pressure relief valves during the operation of the control circuit



Calculation for an assembly device

Evaluation

Schematic diagram

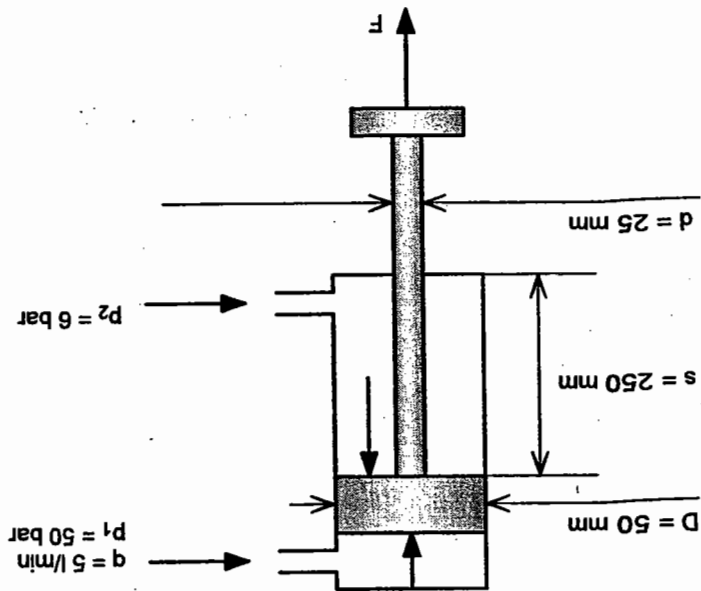

Piston force:

$$F_1 = A_{PN} \cdot p_1 = \frac{\pi}{4} \cdot D^2 \cdot p_1$$

$$F_1 = \frac{\pi}{4} \cdot 50^2 \text{ mm}^2 \cdot 50 \text{ bar}$$

$$F_1 = \frac{\pi}{4} \cdot 50^2 \text{ mm}^2 \cdot 50 \frac{\text{kp}}{\text{cm}^2}$$

$$F_1 = \frac{\pi}{4} \cdot 50^2 \text{ mm}^2 \cdot 50 \frac{\text{kp}}{100 \text{ mm}^2}$$

$$F_1 = 98175 \text{ kp} = 9817.5 \text{ N}$$

$$F_1 = 9.8 \text{ kN}$$

Counter force:

$$F_2 = A_{pH} \cdot p_2 = \frac{\pi}{4} \cdot (D^2 - d^2) \cdot p_2$$

$$F_2 = \frac{\pi}{4} \cdot (50^2 - 25^2) \text{ mm}^2 \cdot 6 \text{ bar}$$

$$F_2 = \frac{\pi}{4} \cdot (50^2 - 25^2) \text{ mm}^2 \cdot 6 \frac{\text{kp}}{\text{cm}^2}$$

$$F_2 = \frac{\pi}{4} \cdot 1875 \text{ mm}^2 \cdot 6 \frac{\text{kp}}{100 \text{ mm}^2}$$

$$F_2 = 88.36 \text{ kp} = 883.6 \text{ N}$$

$$F_2 = 0.9 \text{ kN}$$

Press-fitting force:

$$F = F_1 - F_2 = 9.8 \text{ kN} - 0.9 \text{ kN}$$

$$F = 8.9 \text{ kN}$$

Press-fitting time:

$$t = \frac{V}{V} = \frac{q}{A_{pN} \cdot s} = \frac{q}{\frac{\pi}{4} \cdot D^2 \cdot s}$$

$$t = \frac{4}{\pi} \cdot \frac{50^2 \text{ mm}^2 \cdot 250 \text{ mm}}{5 \frac{\text{mm}}{\text{min}}}$$

$$t = \frac{4}{\pi} \cdot \frac{5^2 \text{ cm}^2 \cdot 25 \text{ cm}}{5000 \frac{\text{cm}^3}{60 \text{ s}}}$$

$$t = \frac{4}{\pi} \cdot \frac{625 \text{ cm}^3 \cdot 60 \text{ s}}{5000 \text{ cm}^3} = \frac{4}{\pi} \cdot \frac{5000}{625 \cdot 60 \text{ s}}$$

$$t = 5.89 \text{ s} \approx 6 \text{ s}$$

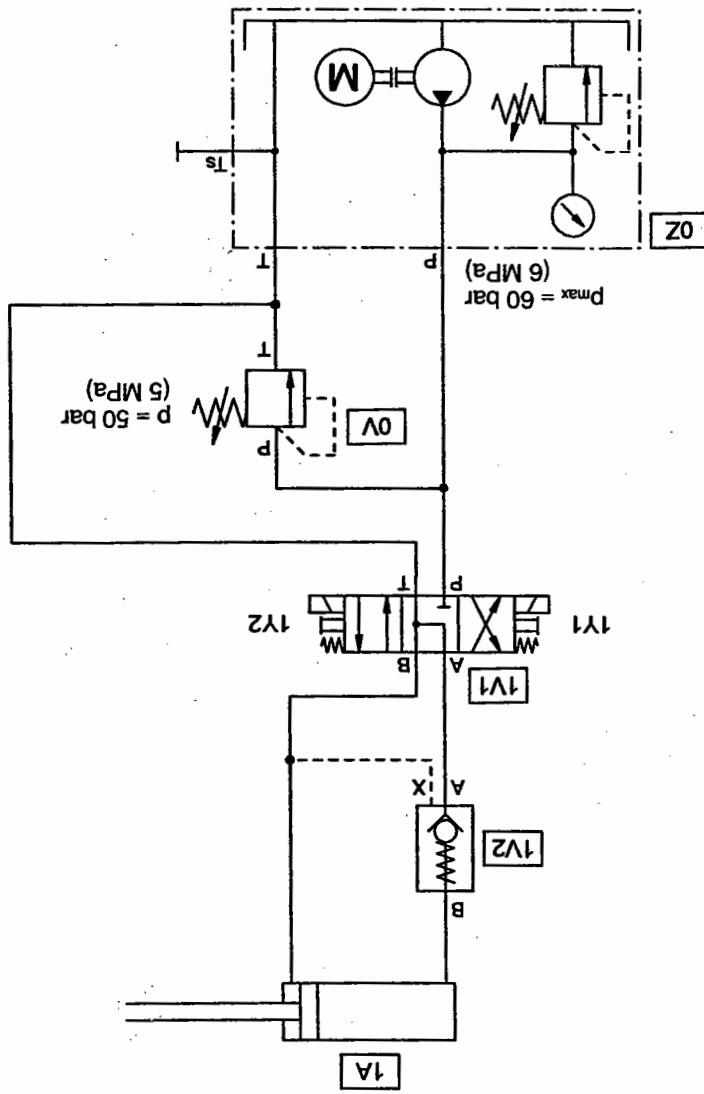

Practical assembly,  
hydraulic

Tipping container

Circuit diagram, electrical

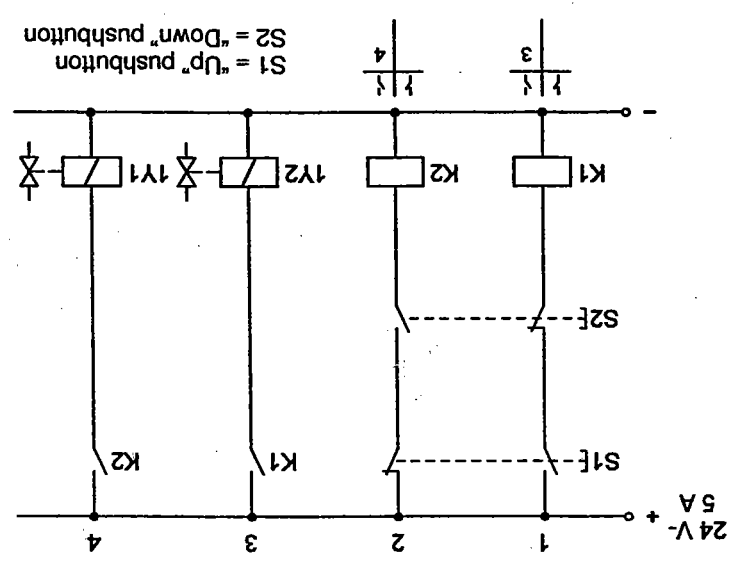

Components list, hydraulic

Item no.	Qty.	Description
0Z	1	Hydraulic power pack
0V	1	Pressure relief valve
1V1	1	4/3-way solenoid valve
1V2	1	Non-return valve, hydraulically piloted
1A	1	Cylinder, double-acting
	6	Hose line
	2	Branch tee

Components list, electrical

Item no.	Qty.	Description
	1	Signal input unit
	1	Relay, 3-fold
	1	Cable set
	1	Power supply unit

A piloted non-return valve is used to protect the tipping container against undesired lowering. A 4/3-way valve with a mid-position in which A, B and T are connected and P is closed is used in order to ensure that the non-return valve closes when the electrical control circuit is switched off. This 4/3-way valve relieves ports A and B in its mid-position.

Once the electrical and hydraulic circuits have been assembled and checked, actuate push-button S1. This causes the cylinder piston rod to travel to its forward end position (filling position). When the push-button S1 is released, a spring force causes the 4/3-way valve to switch to its mid-position. The load acting on the piston rod now causes the pilot-operated non-return valve to close, which prevents the piston rod from being pushed back. When the push-button S2 is actuated, the 4/3-way valve reverses. The pressure which builds up in the line from port B of the valve causes the non-return valve to open and the piston rod of the cylinder travels into its retracted end position (emptying position).

The two push-buttons S1 and S2 each actuate one normally-open and one normally-closed contact, which are connected together in such a way that no movement occurs if the push-buttons are actuated simultaneously.



It is also possible to carry out these exercises using the 4/3-way valve with recirculating mid-position which is included in the equipment set. Due to the inherent characteristics of this valve, internal leakage losses can occur which will cause the piloted non-return valve to close.

The electrical circuit diagram incorporates an interlock between current paths 1 and 2. This ensures that the control circuit will work correctly even in the case of operator error.

**Conclusions**



Use only NITROGEN to fill the accumulator (green cylinders)!!!  
 Never use oxygen. This would create in an EXPLOSION HAZARD!!!



Before disconnecting the accumulator unit from a pressure system, open the shut-off valve (5) or drain the unit. Ensure that the return line (8) is connected up while the unit is in operation.

The pressure vessel (2) is filled via port (4) with the shut-off valve (5) open. This causes the gas volume, separated from the hydraulic fluid by the accumulator diaphragm, to be compressed. As the pressure at port (4) falls, the previously-compressed gas volume expands and displaces the fluid stored in the pressure vessel. The volume of stored fluid corresponds to the change in gas volume between the minimum working pressure and the instantaneous pressure. The instantaneous working pressure is shown on the pressure gauge (6). The pressure relief valve (7) protects the accumulator against pressure overload. The gas valve (1) allows the gas filling pressure of the accumulator to be checked and corrected with the aid the filling and test device (Order no. 092491).

Function

This accumulator is mounted on a block which contains the associated safety circuit. (mounting variant "C").  
 The component is fitted to the profile plate using cheese-head bolts and T-head nuts.  
 The accumulator consists of:  
 Gas valve (1), pressure vessel (2), shut-off block (3), supply port (4), 3/3-way valve with hand lever (shut-off valve) (5), pressure gauge (6), pressure relief valve (7), tank connection (8)

Design

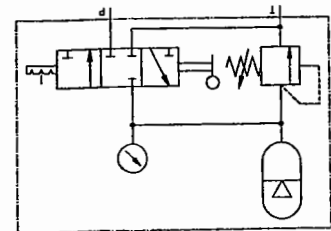
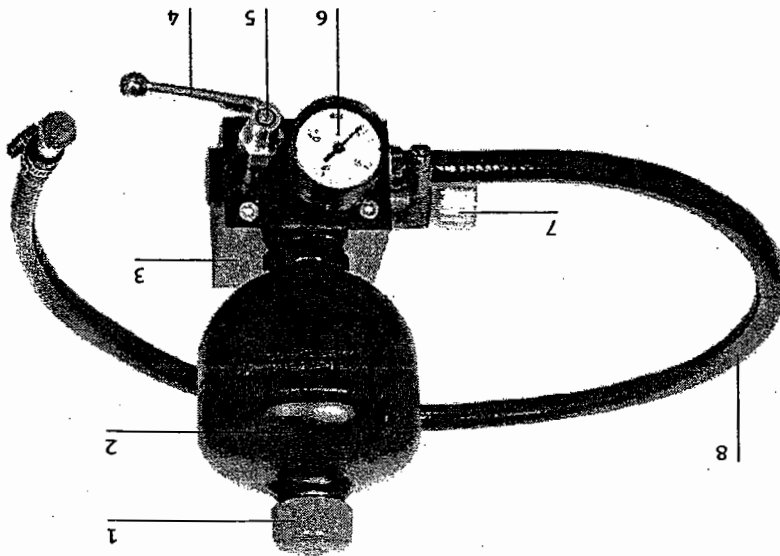

Diaphragm accumulator with shut-off block

152859

Note concerning the filling of the accumulator

Gas filling pressure, general  
 $p_0 = 0.9 \cdot p_1$   
 Gas filling pressure, minimal  
 $p_{min} = 0.25 \cdot p_2$   
 Gas filling pressure, maximal  
 $p_{max} = 0.25 \cdot p_{max}$

Gas filling pressure, temperature-dependent

$$p_{temp} = p_0 \cdot \frac{\text{Filling temperature}}{\text{Operating temperature}}$$

$p_0$  = Gas filling pressure

$p_1$  = Lower operating pressure

$p_2$  = Upper operating pressure

$p_{max}$  = Max. permissible operating pressure

Lower operating pressure

$$p_1 = 11 \text{ bar}$$

Upper operating pressure

$$p_2 = 40 \text{ bar}$$

Max. permissible operating pressure

$$p_{max} = 120 \text{ bar}$$

Gas filling pressure, general

$$p_0 = 0.9 \cdot 11 \text{ bar} = 10 \text{ bar}$$

Gas filling pressure, minimal

$$p_{min} = 0.25 \cdot 40 \text{ bar} = 10 \text{ bar}$$

Gas filling pressure, maximal

$$p_{max} = 0.25 \cdot 120 \text{ bar} = 30 \text{ bar}$$

Example

Technical data

Hydraulic	
Medium	Gas: Nitrogen Fluid: Mineral oil, recommended viscosity 22 cSt (mm <sup>2</sup> /s)
Max. permissible pressure $p_{max}$	12 MPa (120 bar)
Gas filling pressure as supplied $p_0$	1 MPa (10 bar)
Nominal volume	0.32 dm <sup>3</sup>
Adjustment	Manual
Actuation	Hydraulic
Connections	For 1 quick-acting coupling (P) For 1 blue coupling socket (TS on hydraulic power pack)



152960, 152970, 159386, 158352

Hose line with quick release coupling (600, 1000, 1500, 3000 mm)

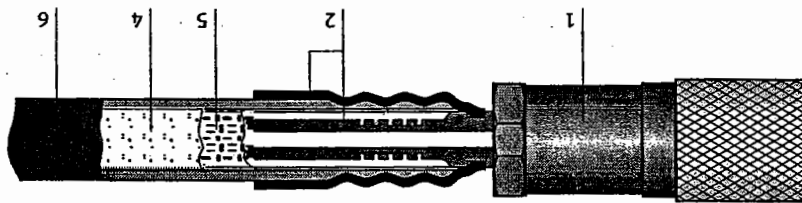
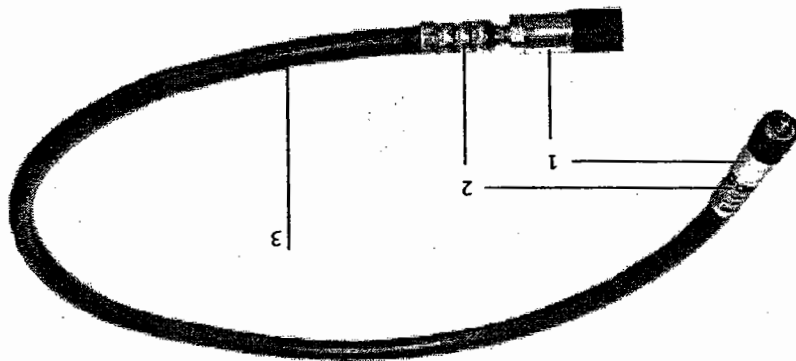

Design

Coupling socket (1), fitting (2), high-pressure hose (3), braided wire (4), inner hose (5), cover sheath (6). The high-pressure hose (3) is of 3-ply design. The inner hose (5) is made of synthetic rubber, the 2nd ply of braided wire (4) and the cover sheath (6) of abrasion-resistant synthetic rubber.

Function

The two coupling sockets (1) are self-closing when uncoupled. These sockets provide a leakproof hydraulic connection in conjunction with the coupling nipple (7). To make a connection, the coupling socket (1) is pushed onto the nipple until the sliding sleeve (8) snaps forward. This sleeve is pulled back to separate the connection. The coupling socket will then spring away from the nipple. Only the front faces of the couplings come into contact with hydraulic fluid during the coupling operation.

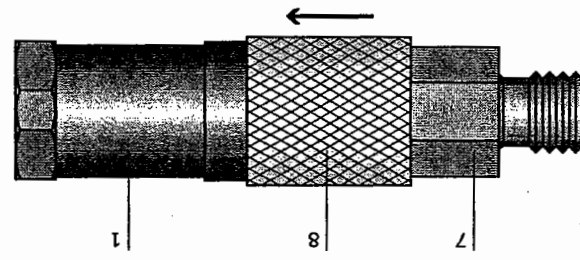

Pressure/flow-rate characteristic

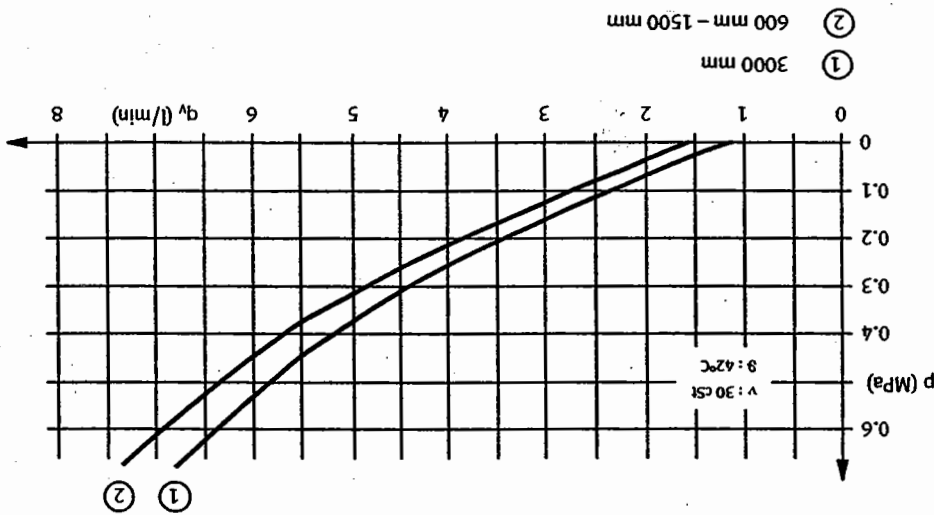

- Carry out coupling and decoupling only at zero pressure.
- In order to obtain a long service life with the hose lines, ensure that they are not twisted while assembling circuits and observe the specified minimum bending radius and operating temperature.
- The storage and use of hose lines are governed by the following safety regulations:
  - The maximum storage time is 4 years for hoses without fittings and 2 years for hoses with fittings.
  - Hose lines should not be used for longer than 6 years, including a storage period of a maximum of 2 years.
  - Hoses are marked with their date of production (quarter and year) e.g.: 1 Q 92.
  - Hose line fittings are marked with their date of production (month and year) e.g.: 10 93.
- Fittings (2) are stamped with their maximum operating pressure.

Notes

152960, 152970, 159386, 158352

Hose line with quick release coupling (600, 1000, 1500, 3000 mm)

**152960, 152970, 159386, 158352**  
 Hose line with quick release coupling (600, 1000, 1500, 3000 mm)

Technical data

Type of Hose (Order No.)	152960	152970	159386	158352
Medium	Mineral oil, recommended viscosity 22 cSt (mm <sup>2</sup> /s)			
Hose length	600 mm	1000 mm	1500 mm	3000 mm
Nominal size	6 mm			
Operating pressure p	6 MPa (60 bar)			
Max. permissible pressure p <sub>max</sub>	12 MPa (120 bar)			
Temperature range	-40 – +125 °C			
Bending radius, min.	100 mm			
Connections	For 2 coupling nipples			



152962, 159328

Hydraulic power pack 2 l/min

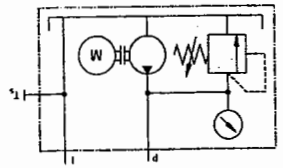
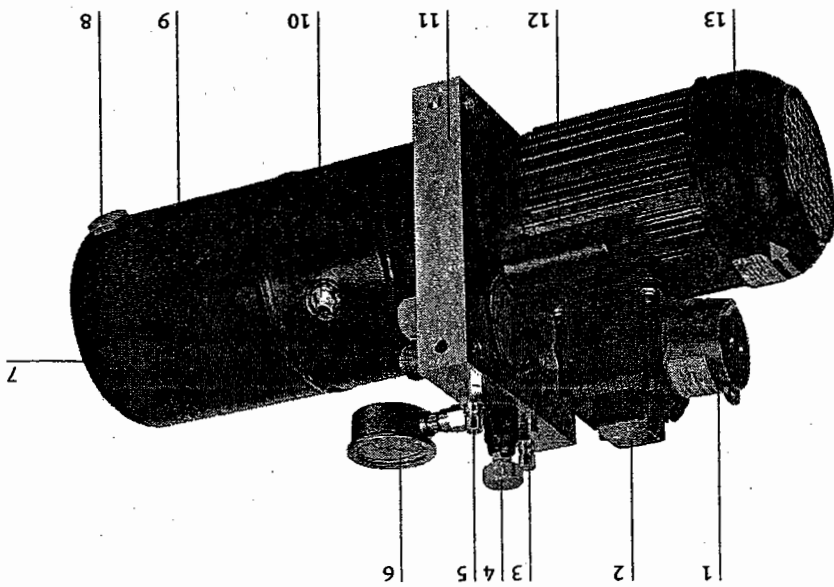

Design

The power supply unit is fitted on a flange. The device is mounted on the profile plate or another fixture by means of profile connectors (mounting variant "C"). (1) Power supply plug, (2) ON/OFF switch, (3) Pressure port P, (4) Pressure-relief valve, (5) Tank connection T, (6) Pressure gauge, (7) Tank connection (blue) for reservoir TS, (8) Drain screw, (9) Tank, (10) Sight glass for level indicator, (11) Flange, (12) Capacitor, (13) Electric motor.

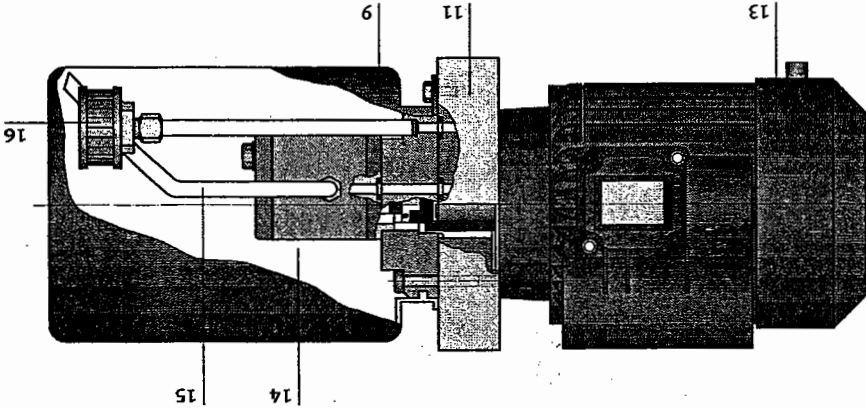



Function

The hydraulic power pack converts electrical energy into hydraulic drive power. The electric motor (13) drives a gear pump (14). The oil is fed from the tank (9) via the suction pipe (15) and applied at pressure port. The pressure can be read from the pressure gauge (6). The pump delivers a virtually constant flow rate.

The maximum pressure value is set by means of the pressure relief valve (4). This pressure can only be maintained up to the maximum delivery rate of the pump. If the connected hydraulic circuit requires a higher flow rate, the pressure will fall. The pressure prevailing at this point adapts itself to the flow resistance of the connected circuit, whereby the flow rate e.g. on a pump-by-pass circuit, return at low pressure. The return flow is effected via the tank connection T (5) through the return filter (16) into the tank (9). A blue quick coupling socket (7) has been provided for the return flow from the pressure reservoir. The filling level can be read from the sight glass (10).

The hydraulic power pack is supplied without oil. The tank is to be filled with approx. 5 l of hydraulic oil before the initial switching on of the power pack. To fill the tank, the air filter must be unscrewed. The air filter must not be replaced by a blanking plug. Holes have been drilled on three sides of the flange (11), whereby the power pack can be installed in various positions. Profile connectors are used for mounting. Three assembly positions are possible:

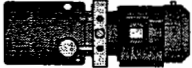
Positions	Description
	Vertical, electric motor facing upwards.
	Horizontal, pressure gauge facing upwards.
	Horizontal, pressure gauge on side with connection T facing downwards. <b>Caution!</b> In this assembly position, the filling level cannot be read from the sight glass.

The power pack is connected to the power supply plug (1) by means of an extension line. The power pack is switched on by means of pressing the green button and switched off via the red button.

In the filled status, the power pack must always be positioned in such a way that the pressurising/venting screw (red) is above the oil level.



Note

- The power pack must be operated using the pressurising/venting screw (red).  
**Caution!**  
Falling this, the tank may burst.
- Regularly check the oil level. The pump must not run dry.
- If an initial start-up of devices takes place, the oil level in the tank is reduced as a result of the displacement. If the oil level can no longer be seen in the sight glass (10), the hydraulic oil must be topped up until the level is visible.
- The power pack is designed for a 50% duty cycle. If continuous operation is required, an external oil cooler is to be used.
- If the thermostatic switch of the electric motor is triggered, the red "off" switch must be actuated after a cooling phase and after checking and eliminating the cause. Normal operation can be re-started following this.
- The hydraulic power pack is not suitable for the connection of a flow measuring container order no. 162344.
- If the hydraulic power pack is moved, carried or transported on a trolley, this can lead to sloshing in the tank. This may cause a small quantity of oil to escape via the air filter.
- If the hydraulic power pack is incorrectly installed, whereby the air filter is below the oil level, the tank will discharge, added to which the pump may run dry.
- An increase in the flow rate by means of interconnecting several hydraulic power packs is not feasible, since it is not possible to compensate the various filling levels inside the tanks.

Technical data

Electrical	152962	159328
	AC current, single-phase, convection-cooled	
Nominal power rating	650 W	550 W
Nominal voltage	230 V	110 V
Nominal current	3.1 A	8.4 A
Frequency	50 Hz	60 Hz
Nominal speed	1320 rpm	1680 rpm
Protection class	IP20	
Duty cycle	50%	
Action	Manual via ON/OFF switch	
Connection	Power supply plug to DIN 49441/CEE7 with additional earthing system.	

Hydraulic	152962	159328
	Mineral oil, recommended viscosity 22 cSt (mm <sup>2</sup> /s)	
Pump design	External gear pump	
Volumetric delivery rate	1.6 cm <sup>3</sup>	1.3 cm <sup>3</sup>
Delivery rate at nominal speed	2.2 l/min	2.3 l/min
Operating pressure	0.5 – 6 MPa (5 – 60 bar)	
Setting	Manual	
Pressure gauge indicating range	0 – 10 MPa (0 – 100 bar)	
Pressure gauge accuracy class	1.6	
Oil tank capacity	approx. 5 l	
Return filter, grade of filtration	90 µm	
Connections	One quick coupling socket for P and T, one coupling for tank line of reservoir (order no. 152859).	

Mechanical		
	Dimensions	Length 580 mm Width 300 mm Height 180 mm
Weight	empty 19 kg filled with oil 24 kg	



Technical data

Mechanical		
Mass	9 kg	
Dimensions	Length 150 mm	Width 100 mm
	Height 80 mm	

Note

Observe general safety rules. Use the protective cover order no. 152973.

Function

Applying loads to a cylinder.  
The weight is locked into a profile groove by turning it through 90°. It can then be attached to the piston rod of the cylinder using the rod eye and clevis.

Design

Steel block, painted, with castors and locking device, rod eye and clevis.

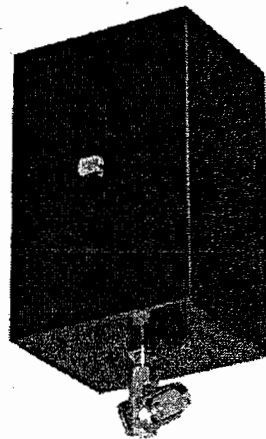

Loading weight, 9 kg

152972



Design

The 4/3-way hand lever valve is mounted on a function plate equipped with four quick coupling connectors. The component is fitted to the grid system of the slotted assembly board by means of the two blue levers (mounting variant "A"). The valve consists of:

- Piston (1), housing (2), spring (3), stem (4), through-guide (5), slide (6) and lever (7).

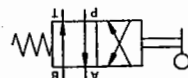
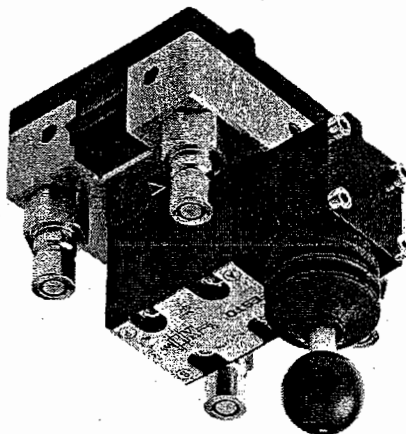
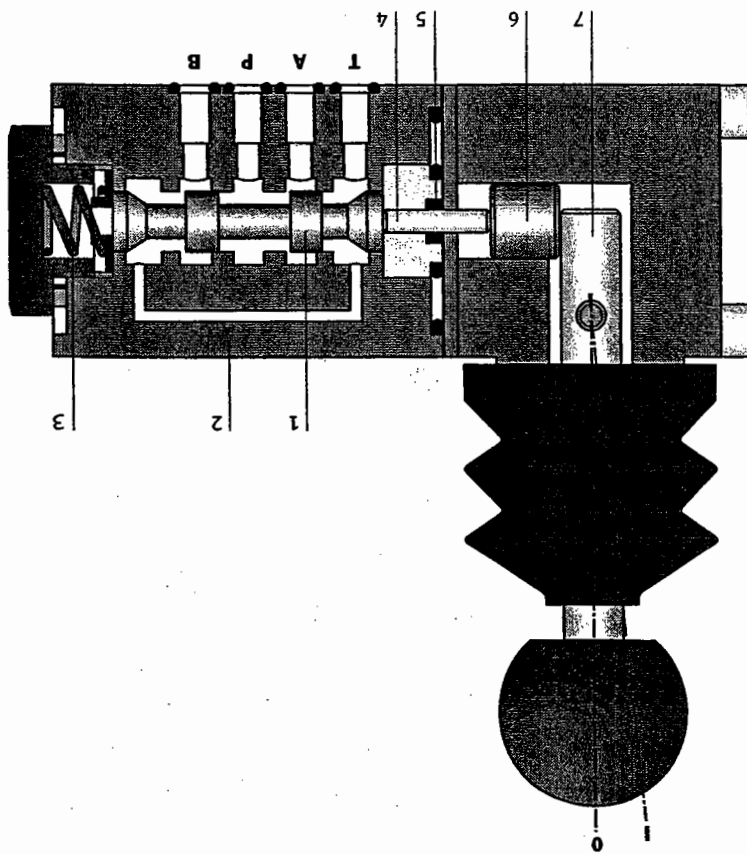

4/2-way hand lever valve

152974

Technical data

Hydraulic	
Medium	Mineral oil, recommended viscosity 22 cst (mm <sup>2</sup> /s)
Operating pressure p	60 bar (6 Mpa)
Max. permissible pressure p <sub>max</sub>	120 bar (12 Mpa)
Actuation	Manual
Connections	Via 4 coupling sockets

Note

The valve ports are identified by letters.  
 A, B Working port  
 P Supply port  
 T Return-line port (tank connection)

Pressure-drop/flow-rate characteristic

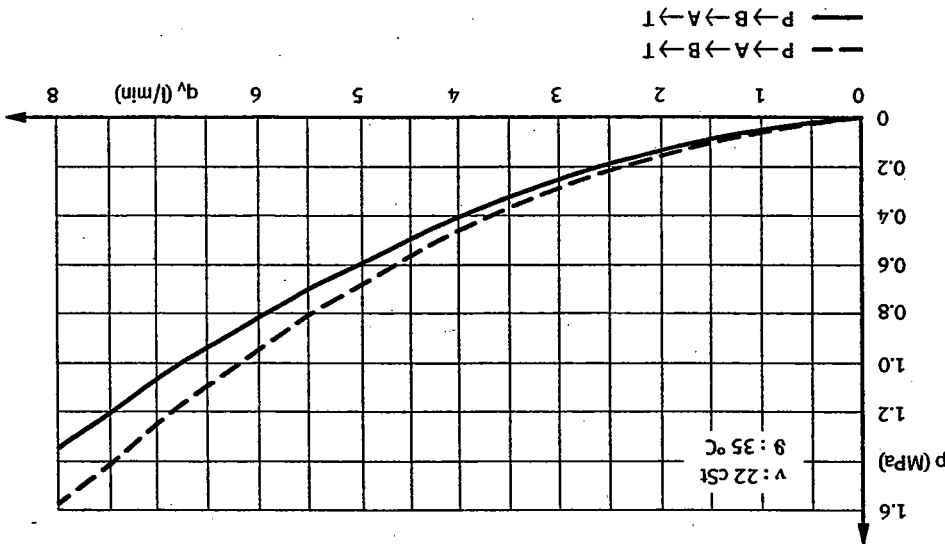

Function

The valve is used for the control of hydraulic flow rates and is actuated manually. It automatically returns into its normal position as a result of spring force. The piston (1) is pressed into the normal position by means of the spring (3) via the stem (4) acting against the slide (6). The valve is sealed by means of the through-guide (5) of the stem (4). The sectional view illustrates the normal position with flow from port A and from port B to port T. The position P to B and A to T is reached by actuating the lever (7), whereby the slide moves the piston (1) against the spring (3) via the stem (4). This position is non-detenting.

Design

The 4/3-way hand lever valve is mounted on a function plate equipped with four quick coupling connectors. The component is fitted to the grid system of the slotted assembly board by means of the two blue levers (mounting variant "A"). The valve consists of:

- Piston (1), housing (2), spring (3), stem (4),
- through-guide (5), round pin (6), eccentric cam (7)
- and lever (8).

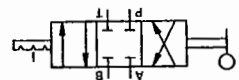
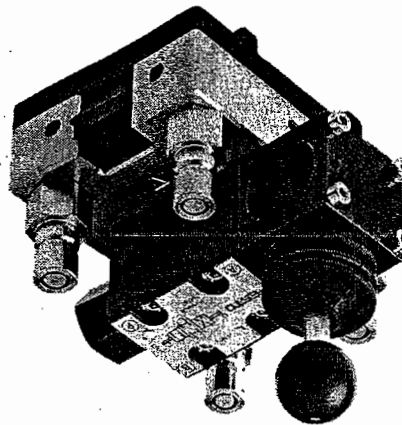
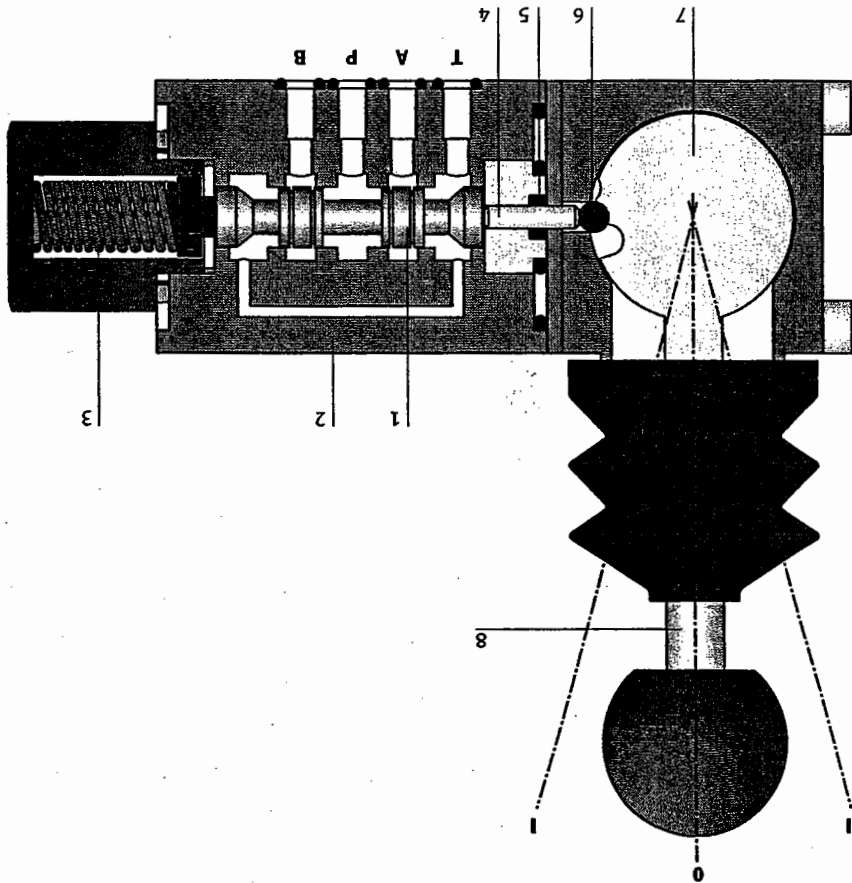

4/3-way hand lever valve with closed mid-position

152975

Function

Used for the control of flow rates, this valve is actuated manually and engages in three positions. Its characteristic, apart from the method of actuation, is the closed mid-position. The piston (1) is pressed against the eccentric cam (7) by means of the spring (3) via the stem (4) and the round pin (6). The T-channel of the eccentric cam chamber is sealed by the through-guide (5) of the stem (4). The round pin (6) in conjunction with the cut-outs in the eccentric cam ensures a detent mechanism. The sectional view illustrates the mid-position with closed ports P, T, A and B. Switching position P to A is obtained by means of lever position I. Here, port P is connected to port A via the annular groove of the piston (1), and simultaneously port B to port T via the second annular groove. Position II of the lever (8) causes port P to be connected to port B via the annular groove of the piston (1) and simultaneously port A to port T via the second annular groove.

Pressure-drop/flow-rate characteristic

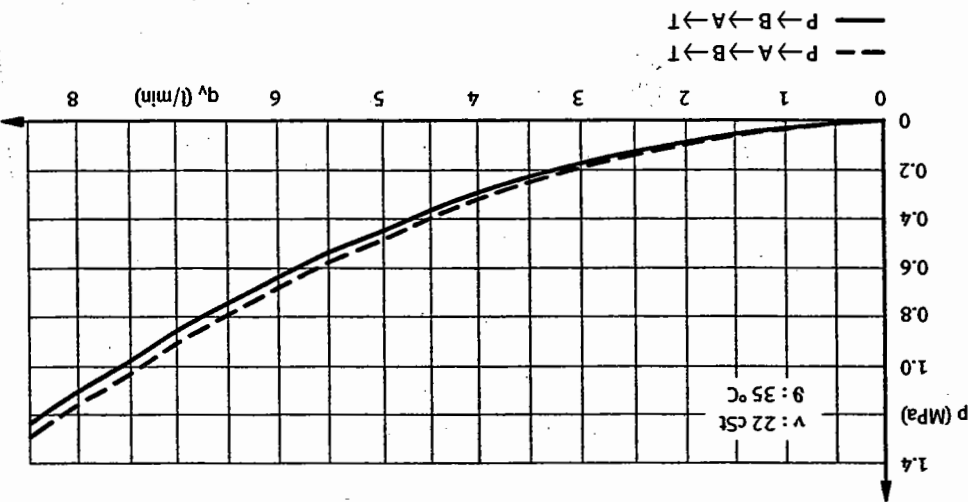

The valve ports are identified by letters.  
 A, B Working port  
 P Supply port  
 T Return-line port (tank connection)

Note

152975

4/3-way hand lever valve with closed mid-position

Technical data

Hydraulic	
Medium	Mineral oil, recommended viscosity 22 cSt (mm <sup>2</sup> /s)
Operating pressure p	60 bar (6 Mpa)
Max. permissible pressure p <sub>max</sub>	120 bar (12 MPa)
Actuation	Manual
Connections	via 4 coupling sockets





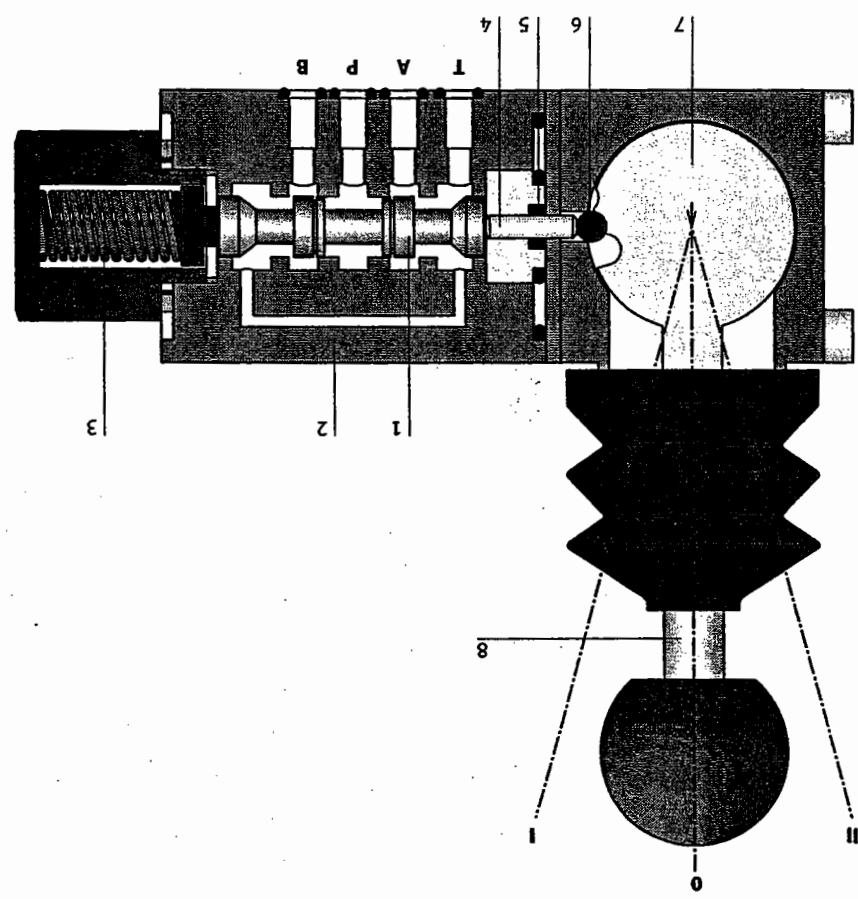
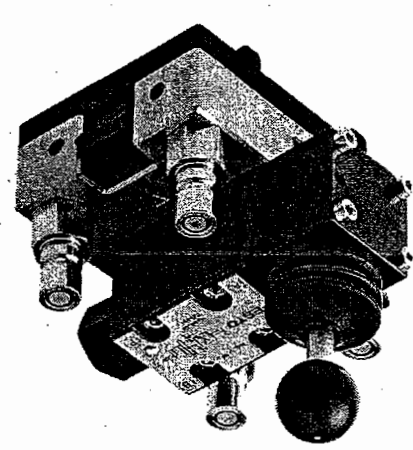
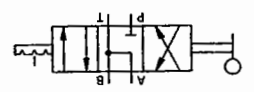

Design

The 4/3-way hand lever valve is mounted on a function plate equipped with four quick coupling connectors. The component is fitted to the grid system of the slotted assembly by means of the two blue levers (mounting variant "A").  
 The valve consists of:  
 Piston (1), housing (2), spring (3), stem (4), through-guide (5), round pin (6), eccentric cam (7) and lever (8).

Function

Used for the control of flow rates, this valve is actuated manually and engages in three positions. Its characteristic, apart from the method of actuation, is that ports A, B and T are connected in the mid-position.

The piston (1) is pressed against the eccentric cam (7) by means of the spring (3) via the stem (4) and the round pin (6). The eccentric cam chamber is sealed off from the T channel via the through-guide (5) of the stem (4). The round pin (6) in conjunction with the cut-outs on the eccentric cam ensures a detent mechanism.

The valve is shown in the mid-position in the sectional view. P is closed and A, B, T are connected. Position I of the hand lever (8) causes the piston (1) to release flow from P to A and to simultaneously connected port B to port T via the second annular groove. Connection P to B is obtained via switching position II of the hand lever (8). This causes port P to be connected to port B via the annular groove of the piston (1) and port A simultaneously to port T via the second annular groove.

Pressure-drop/flow-rate characteristic

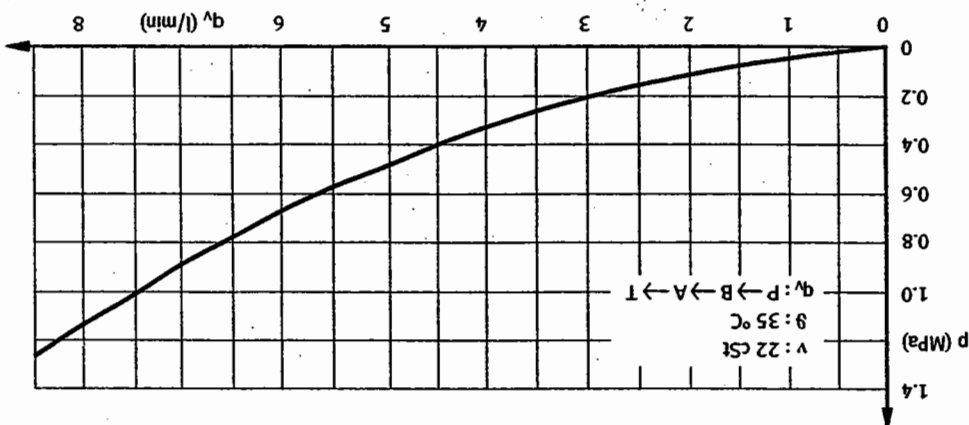

Note  
 The valve ports are identified by letters.  
 A, B Working port  
 P Supply port  
 T Return-line port (tank connection)

Technical data

Hydraulic	
Medium	Mineral oil, recommended viscosity 22 cSt (mm <sup>2</sup> /s)
Operating pressure p	60 bar (6 Mpa)
Max. permissible pressure p <sub>max</sub>	120 bar (12 Mpa)
Actuation	Manual
Connections	Via 4 coupling sockets

4/3-way hand lever valve with relieving mid-position

152976



152977

4/3-way hand lever valve with re-circulating mid-position

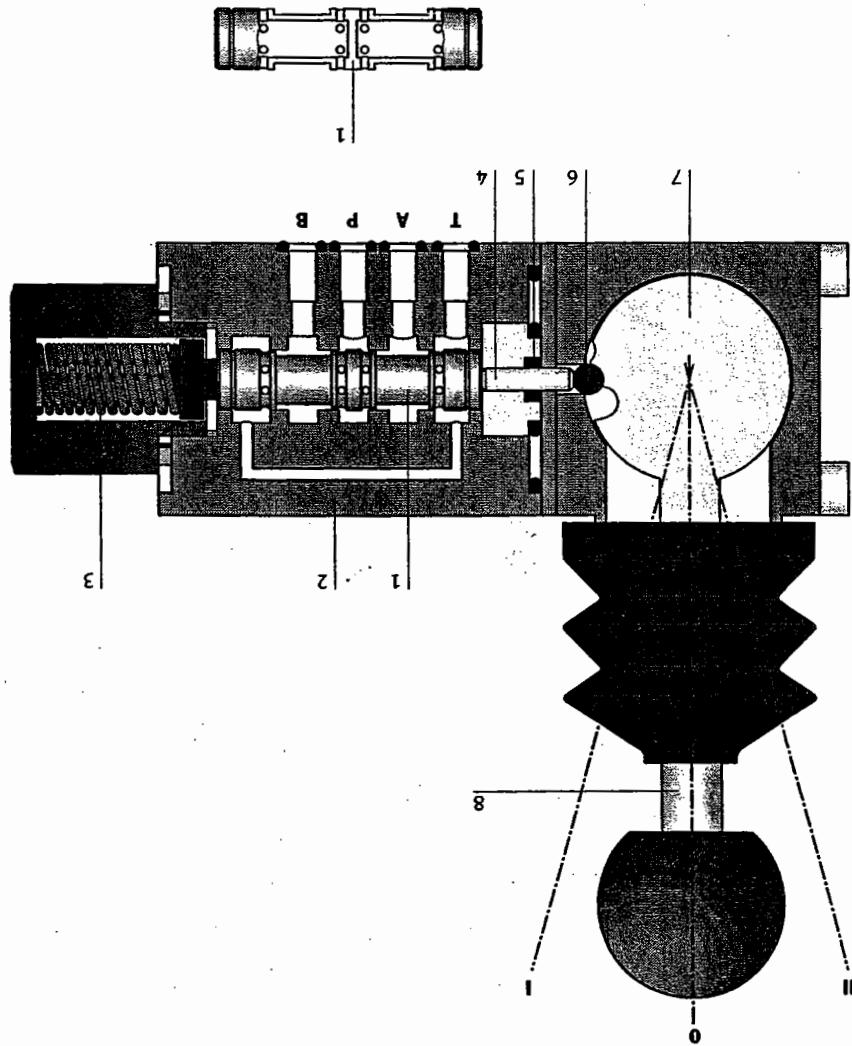
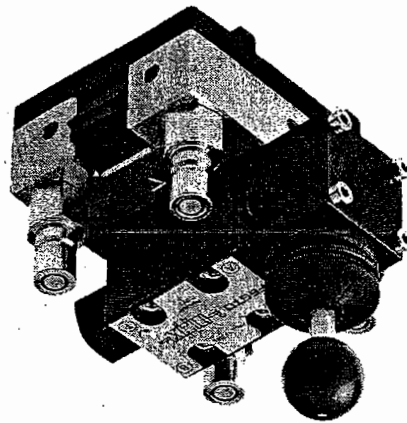
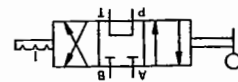

Design

The 4/3-way hand lever valve is mounted on a function plate equipped with four quick coupling connectors. The component is fitted to the grid system of the slotted assembly board by means of the two blue levers (mounting variant "A").  
 The valve consists of: Piston (1), housing (2), spring (3), stem (4), through-guide (5), round pin (6), eccentric cam (7) and lever (8).

Function

Used for the control of volumetric flow rates, this valve is actuated manually and engages in three positions. Characteristic of this valve, apart from its method of actuation, is that port P and T are connected in the mid-position.  
 The piston (1) is pressed against the eccentric cam (7) by the spring (3) via the stem (4) and the round pin (6). The eccentric cam chamber of the T channel is sealed off by the through-guide (5) of the stem (4). The round pin (6) in conjunction with the cut-outs on the eccentric cam ensures a detent mechanism.  
 The sectional view illustrates the mid-position whereby P and T are connected via the hollow piston and port A and B closed. The switching position from P to A is obtained via position II of the hand lever (8). With this, port P is connected to port A via the annular groove of the piston (1) and port B simultaneously to port T via the second annular groove. Position I of the lever (8) causes port P to be connected to port B via the annular groove of the piston (1) and port A simultaneously to port T via the second annular groove.

Pressure-drop/flow-rate characteristic

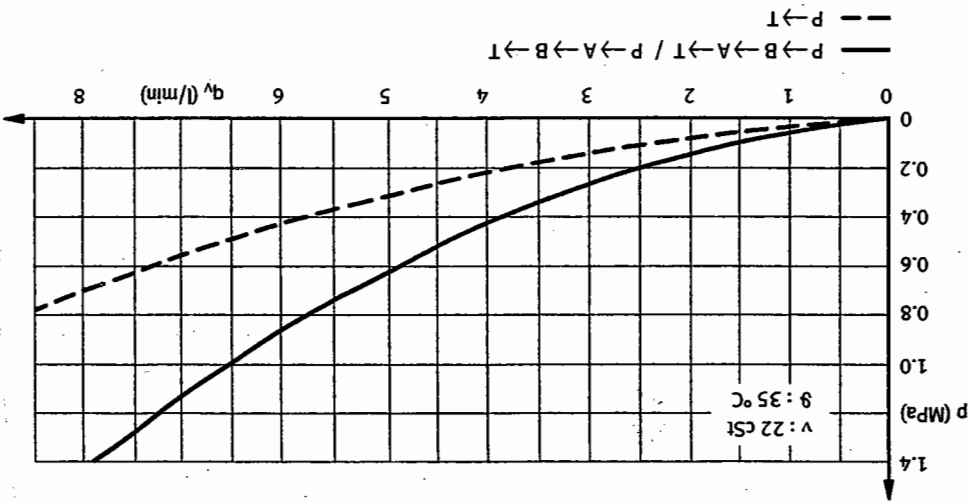

**152977**  
**4/3-way hand lever valve with re-circulating mid-position**

**Note**

The valve ports are identified by letters.  
 A, B Working port  
 P Supply port  
 T Return-line port (tank connection)

**Technical data**

<b>Hydraulic</b>	
Medium	Mineral oil, recommended viscosity 22 cSt (mm <sup>2</sup> /s)
Operating pressure p	60 bar (6 Mpa)
Max. permissible pressure p <sub>max</sub>	120 bar (12 Mpa)
Actuation	Manual
Connections	Via 4 coupling sockets





Function

The relay consists of a coil with a core (1) and winding (3) with connection lugs (7), an armature (4), a return spring (2) and a contact assembly with four changeover contacts (5) and connection lugs (6). When power is applied to the coil connections, current flows through the winding, creating a magnetic field. The armature is pulled onto the coil core and the contact assembly is actuated. Electrical circuits are opened or closed via this assembly. When the electrical current is removed, the magnetic field collapses and the armature and contact assembly are returned to their original position by a return spring.

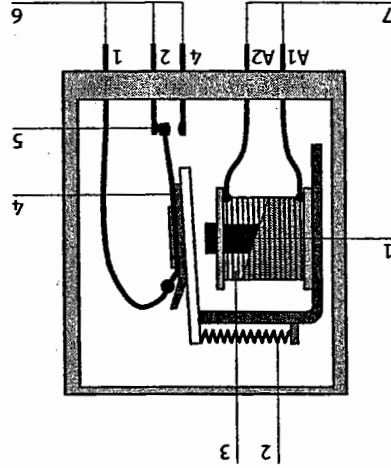

Design

This component consists of three relays with connections and two bus-bars for the power supply. All electrical connections are in the form of 4 mm sockets. The unit can be mounted in a mounting frame or on the profile plate using four plug-in adapters.

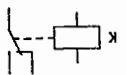
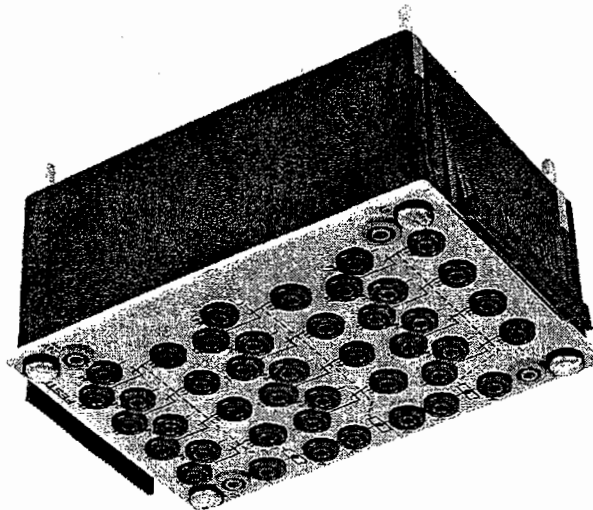

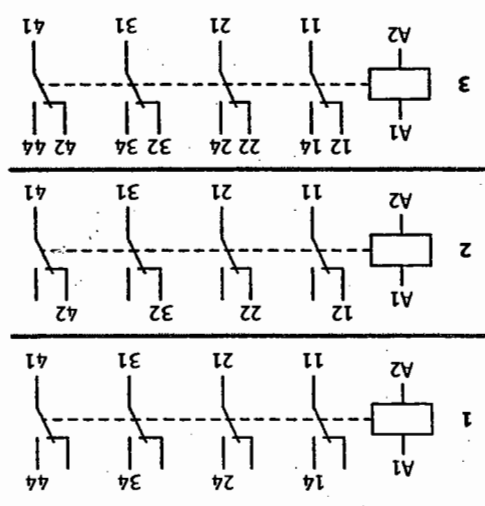

Note

The switching status of the relays is indicated by LEDs, which are protected against incorrect polarity.  
 The four changeover contacts of the contact assembly can be used as normally-open contacts (1), normally-closed contacts (2) or changeover contacts (3).

Normally-open contacts, normally-closed contacts: Allocation of contacts on relay plate

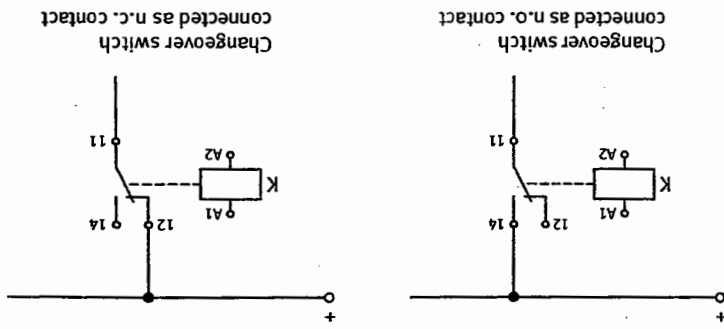

Example of application: Practical assembly, electrical

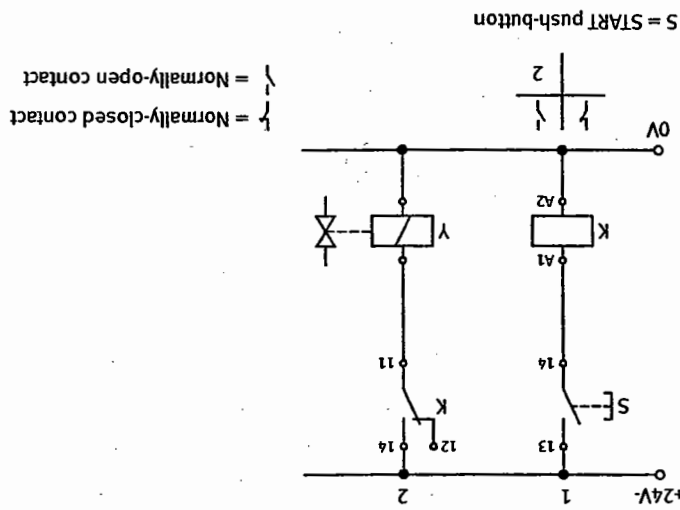

Example of application: Circuit diagram, electrical

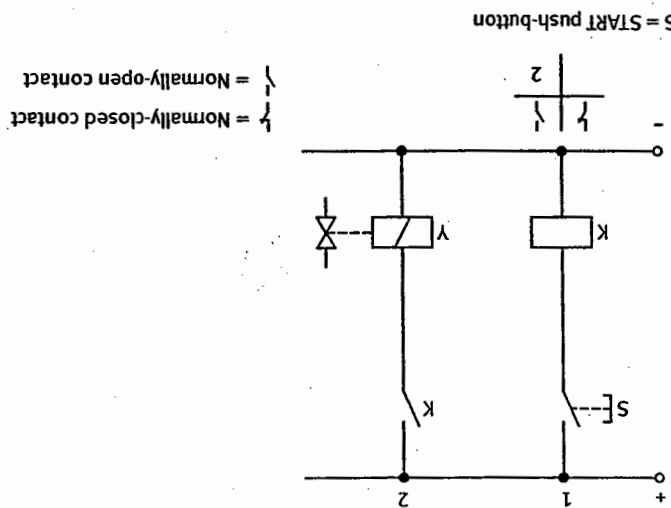

<b>Electrical</b>	
Voltage	24 V DC
Contact assembly	4 changeover contacts
Contact rating	Max. 5 A
Contact interrupt rating	Max. 90 W
Pickup time	10 ms
Drop-off time	8 ms
Connections	For 4 mm safety connector plug
Electromagnetic compatibility	
Emitted interference	tested to EN 500 81-1
Noise immunity	tested to EN 500 82-1

Note

When power is applied to the connections of the visual indicator, the switching status is displayed by the built-in miniature lamp in the pushbuttons.

Function

The illuminated pushbutton in the form of a detented switch consists of a contact assembly with two normally-open contacts and two normally-closed contacts, together with a colourless transparent pushbutton cap with a miniature lamp. The contact assembly is actuated by pressing this cap. Electrical circuits are opened or closed via the contact assembly. When the cap is released, the switching status is maintained. The contact assembly is returned to its initial position by pressing the pushbutton a second time. The illuminated pushbuttons in the form of momentary-contact switches consist of a contact assembly with two normally-open contacts and two normally-closed contacts, together with a colourless transparent pushbutton cap with a miniature lamp. The contact assembly is actuated by pressing this cap. Electrical circuits are opened or closed via the contact assembly. When the cap is released, the switching status is maintained. The contact assembly is returned to its initial position by pressing the pushbutton a second time.

Design

This component consists of two illuminated pushbuttons in the form of momentary-contact switches and one illuminated pushbutton in the form of a detented switch. All electrical connections are in the form of 4 mm safety connectors. The unit can be mounted in a mounting frame or on the profile plate using four plug-in adapters.

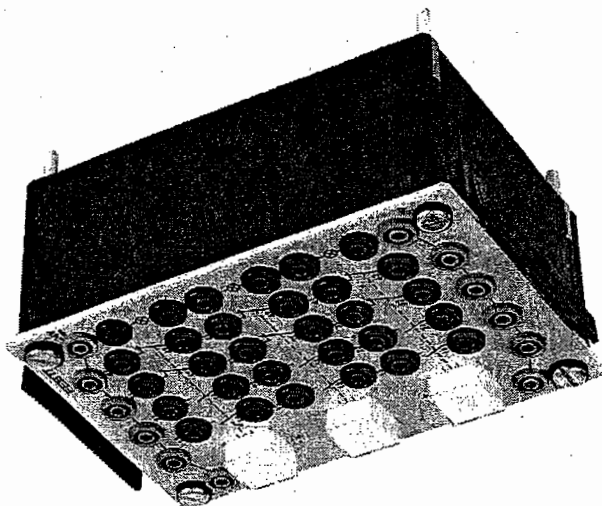
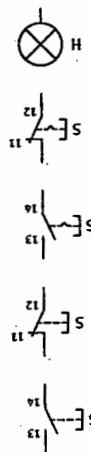

Signal input plate, electrical

162242

Example of application: Circuit diagram, electrical

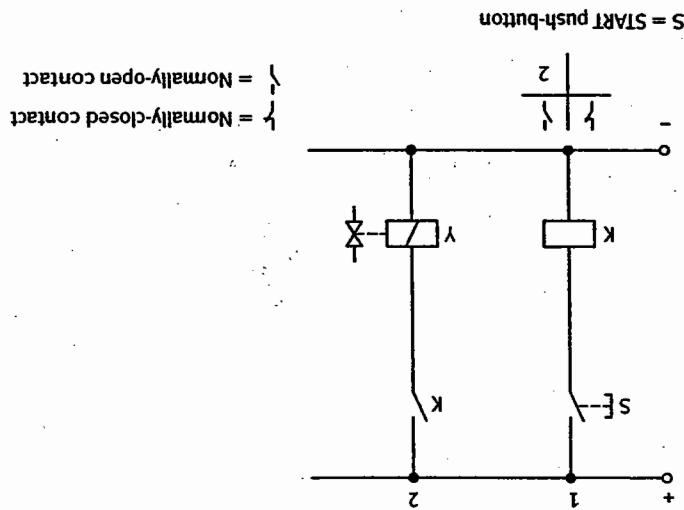

Example of application: Practical assembly, electrical

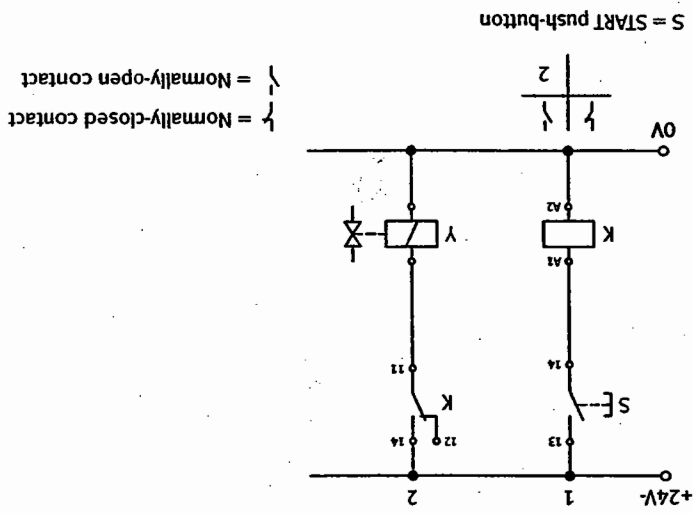

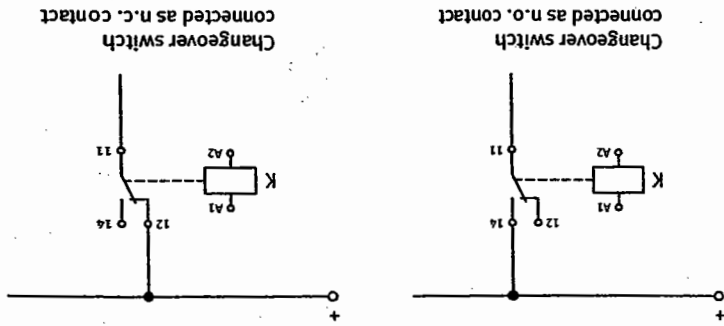

Normally-open contacts, normally-closed contacts: Allocation of contacts on relay plate

Technical data

<b>Electrical</b>	
Voltage	24 V DC
Contact assembly	2 normally-open contacts, 2 normally-closed contacts
Contact rating	Max. 1 A
Power consumption (miniature lamp)	0.48 W
Connections	For 4 mm safety connector plug
Electromagnetic compatibility	
Emitted interference	tested to EN 500 81-1
Noise immunity	tested to EN 500 82-1





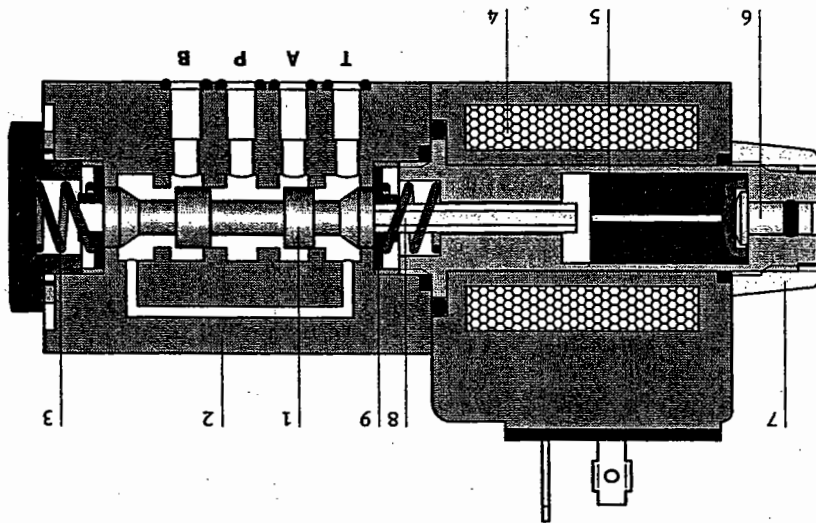
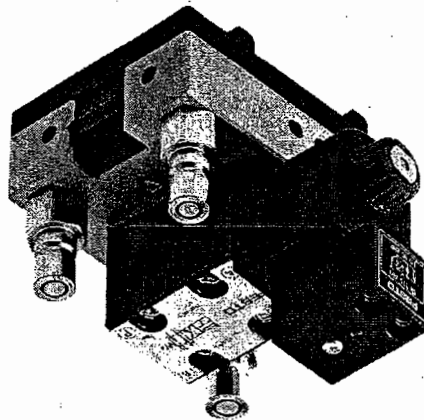
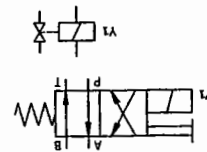

Design

The 4/2-way solenoid valve is mounted on a function plate equipped with four quick coupling connectors. The component is fitted to the grid system of the slotted assembly board by means of the two blue levers (mounting variant "A"). The valve consists of: Piston (1), housing (2), spring (3), solenoid coil (4), plunger (5), emergency manual override (6), nut (7), stem (8) spring disc (9).

Function

This directional control valve comprises two switching positions for the control of flow rates. It is directly actuated via a DC solenoid coil. Characteristic of this valve is the spring return normal position.

The valve is shown in its normal position in the sectional view, whereby ports P and A as well as ports B and T are connected. The piston (1) is clamped in the housing between the springs and spring discs when the solenoid is de-energised. If voltage is applied to the solenoid coil Y1 (4), the plunger (5) presses the piston (1) against the opposite spring via the stem (8), thereby connecting port P to B and port A to T. The switching solenoid consists of a pressure tube, the push-on coil body is attached via the nut (7) and the stem (8). The electrical connection is effected via a valve plug socket.

An emergency manual override (9) facilitates actuation without electrical energy.

Pressure-drop/flow-rate characteristic

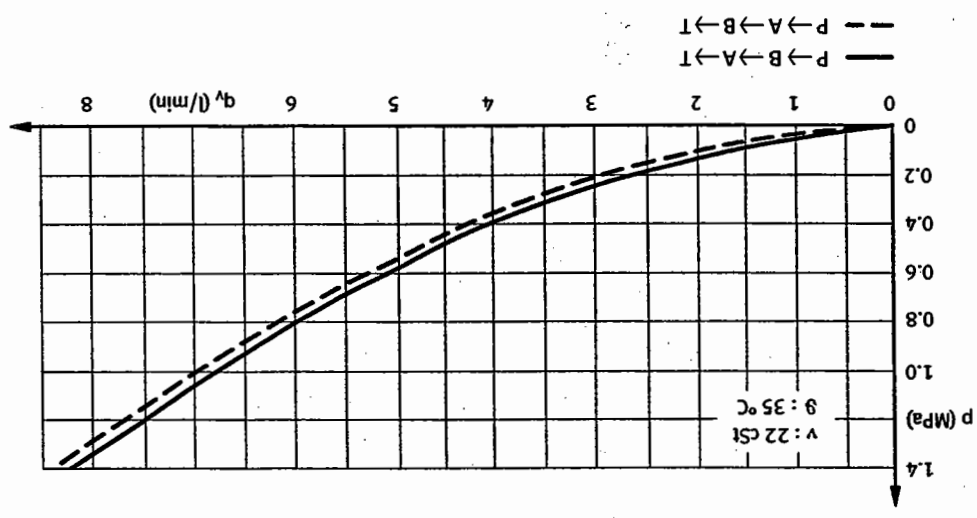

Note

The valve ports are identified by letters.

A, B Working ports

P Supply port

T Return-line port (tank connection)

The electrical connections are protected against overvoltage. The switching status is indicated by an LED.

The manual override must not be actuated by means of sharpened objects (e.g. screwdrivers) so that its smooth operation and leak-proofness is maintained. A stiff manual override may result in malfunction of the solenoid valve.

Technical data

Hydraulic	
Medium	Mineral oil, recommended viscosity 22 cSt (mm <sup>2</sup> /s)
Operating pressure p	60 bar (6 Mpa)
Max. permissible pressure p <sub>max</sub>	120 bar (12 Mpa)
Voltage	24 V DC
Power rating	6.5 W
Actuation	Electrical
Connections, electrical	Via 4 mm safety connector plug
Connections, hydraulic	Via 4 coupling sockets



The 4/3-way solenoid valve is mounted on a function plate equipped with four quick coupling connectors. The component is fitted to the grid system of the slotted assembly board by means of the two blue levers (mounting variant "A"). The valve consists of: Piston (1), housing (2), spring (3), solenoid coil (4), plunger (5), spring disc (6), stem (7), emergency manual override (8), nut (9), pressure tube (10).

Design

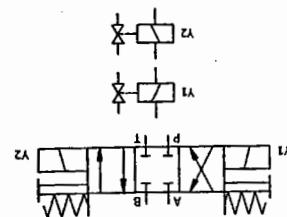
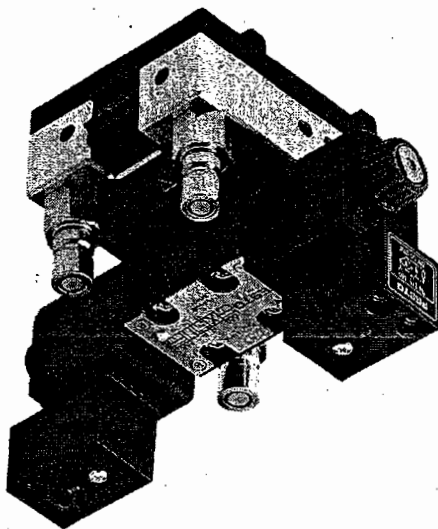
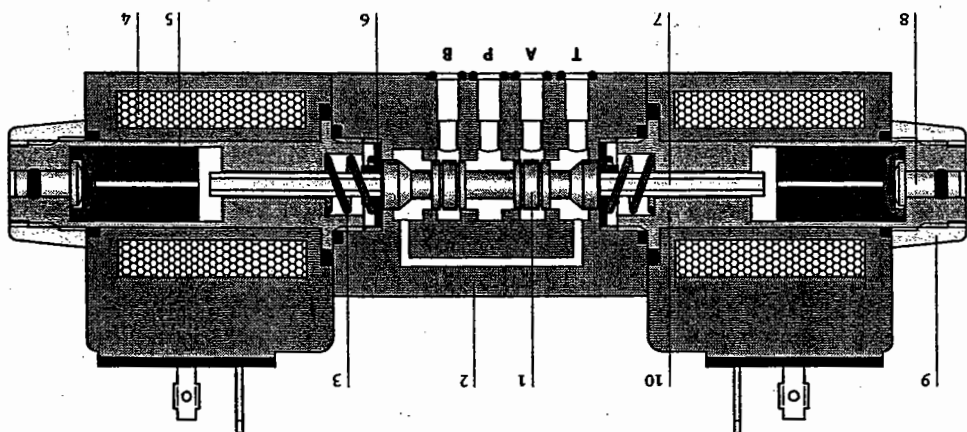

4/3-way solenoid valve, closed in mid-position

167083

Function

This directional control valve comprises 3 switching positions for the control of flow rates and is directly actuated via DC solenoid coils. Characteristic of this valve is its mid-position, whereby ports A, B, P and T are closed. The valve is shown in its mid-position in the sectional view. The valve assumes this position via the two compression springs, if neither of the two solenoids are energised (spring force). By applying voltage (energising) to the solenoid coil Y2 (4), the plunger (5) presses the piston (1) against the spring opposite via the stem. This causes port P to be connected to port A via the annular groove of the piston (1) and port B simultaneously to port T via the second annular groove. By energising the solenoid coil Y1, the piston is pushed into the opposite direction. This causes port P to be connected to port B via the annular groove of the piston (1) and port A to port T via the second annular groove. The switching solenoid consists of the pressure tube (10), the push-on coil body which is attached by means of the nut (9) and the stem (7). The electrical connection is effected via a valve plug socket. An emergency manual override (8) also facilitates actuation without electrical energy.

Pressure-drop/flow-rate characteristic

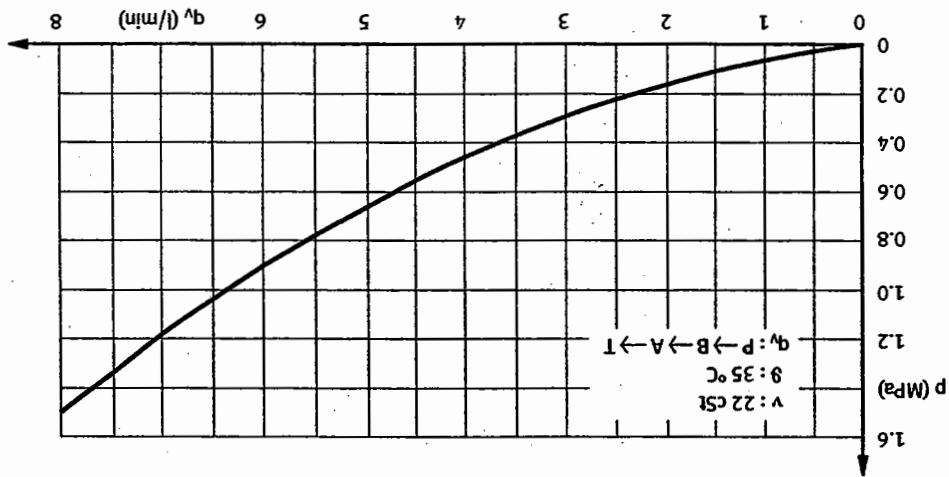

Note

The valve ports are identified by letters.

A, B Working ports

P Supply port

T Return-line port (tank connection)

The electrical connections are protected against overvoltage. The switching status is indicated by an LED.

The emergency manual override must not be actuated by means of sharp-edged objects (e.g. screwdriver) so that its smooth operation and leak-proofness are maintained. A stiff manual override may result in malfunction of the solenoid valve.

Technical data

Hydraulic	
Medium	Mineral oil, recommended viscosity 22 cSt (mm <sup>2</sup> /s)
Operating pressure p	60 bar (6 Mpa)
Max. permissible pressure p <sub>max</sub>	120 bar (12 Mpa)
Voltage	24 V DC
Power rating	6.5 W
Actuation	Electrical
Connections, electrical	Via 4 mm safety connector plug
Connections, hydraulic	Via 4 coupling sockets





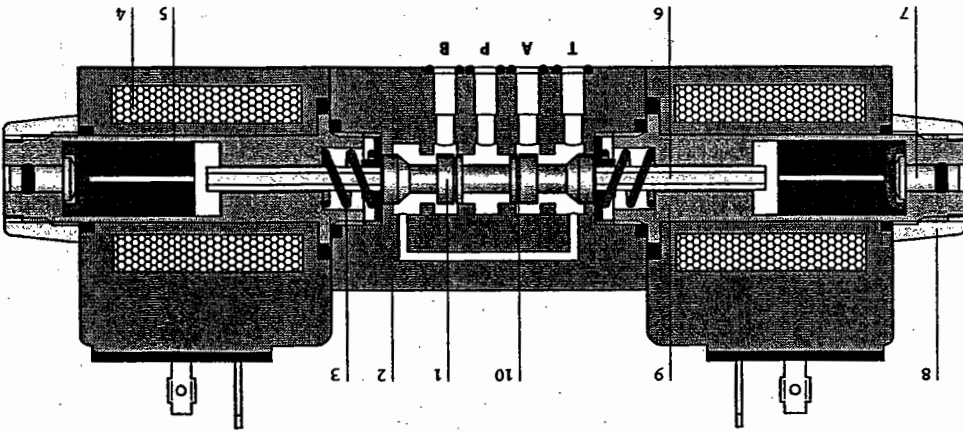
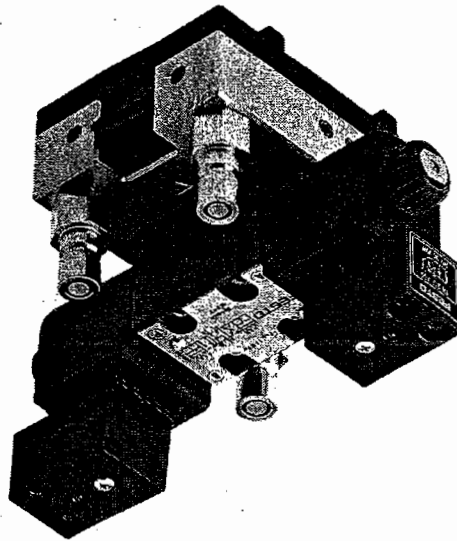
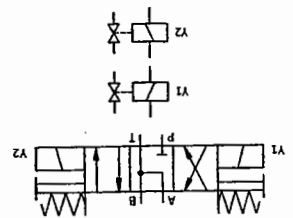

Design

The 4/3-way solenoid valve is mounted on a function plate equipped with four quick coupling connectors. The component is fitted to the grid system of the slotted assembly board by means of the two blue levers (mounting variant "A").  
 The valve consists of: Piston (1), housing (2), spring (3), solenoid coil (4), plunger (5), stem (6), emergency manual override (7), nut (8), pressure tube (9), pressure relieving groove (10).

Function

This directional control valve comprises 3 switching positions for the control of flow rates and is directly actuated via DC solenoid coils. Characteristic of this valve is the mid-position, whereby ports A, B and T are interconnected. The valve is shown in the mid-position in the sectional view. The valve assumes this position via the two compression springs if neither of the two solenoids is energised (spring force). By applying voltage to (energising) the solenoid coil Y2 (4), the plunger (5) presses the piston (1) against the spring opposite via the stem. This causes Port P to be connected to port A via the annular groove of the piston (1) and port B simultaneously to port T via the second annular groove. By energising solenoid coil Y1, the piston is pushed into the opposite direction. This causes port P to be connected to port B via the annular groove of the piston (1) and port A to port T via the second annular groove. The switching solenoid consists of the pressure tube (9), the push-on coil body which is attached via the nut (8) and the stem. The electrical actuation is effected via a valve plug socket. An emergency manual override (7) also facilitates actuation without electrical energy. The pressure relieving groove (10) reduces the peripheral lateral forces, whereby static friction at high pressure can be considerably reduced.

Pressure-drop/flow-rate characteristic

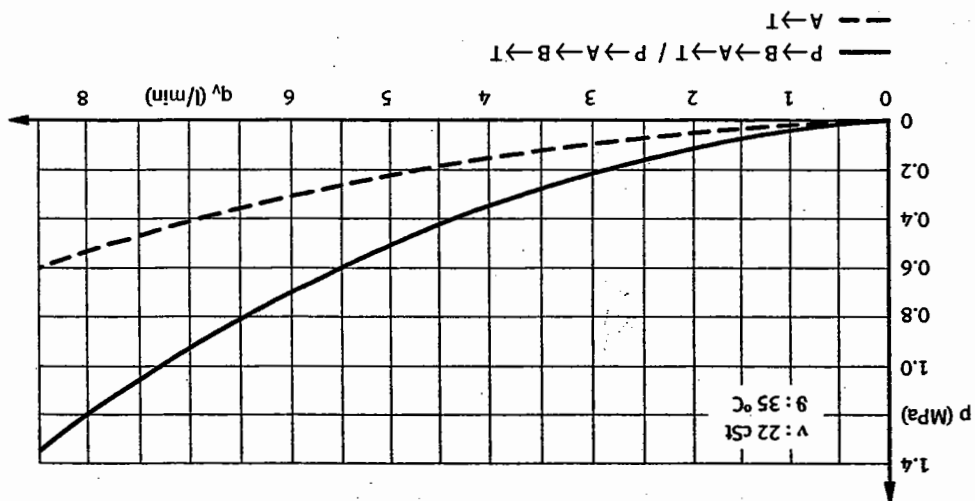

167084

4/3-way solenoid valve with relieving mid-position

Note

The valve ports are identified by letters.  
A, B Working ports  
P Supply port  
T Return-line port (tank connection)

The electrical connections are protected against overvoltage. The switching status is indicated by an LED.

The emergency manual override must not be actuated by means of sharp-edged objects (e.g. screwdrivers) so that its smooth operation and leak-proofness are maintained. A stiff manual override may result in malfunction of the solenoid valve.

Technical data

Hydraulic	
Medium	Mineral oil, recommended viscosity 22 cSt (mm <sup>2</sup> /s)
Operating pressure p	60 bar (6 Mpa)
Max. permissible pressure p <sub>max</sub>	120 bar (12 Mpa)
Voltage	24 V DC
Power rating	6.5 W
Actuation	Electrical
Connections, electrical	Via 4 mm safety connector plug
Connections, hydraulic	Via 4 coupling sockets



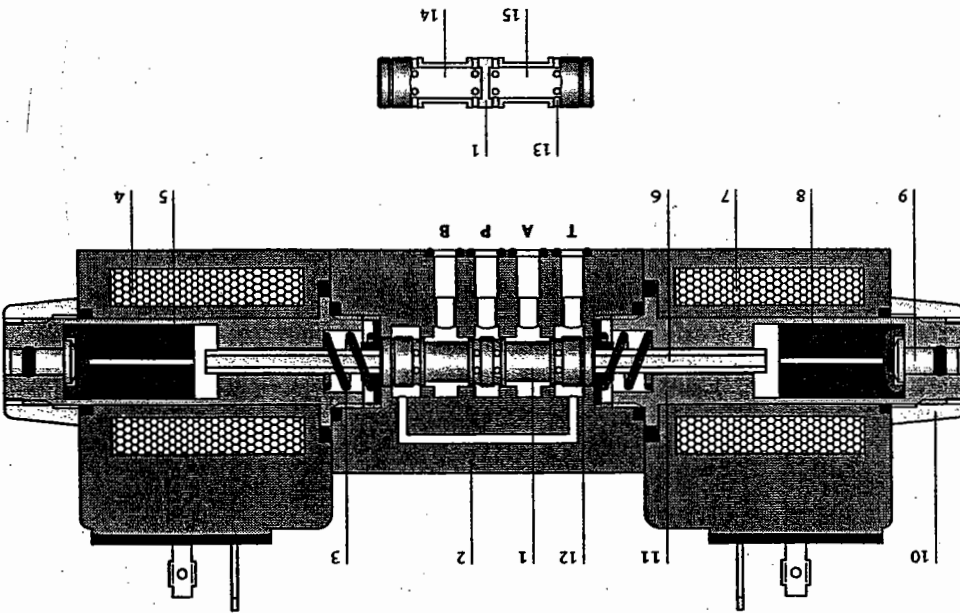
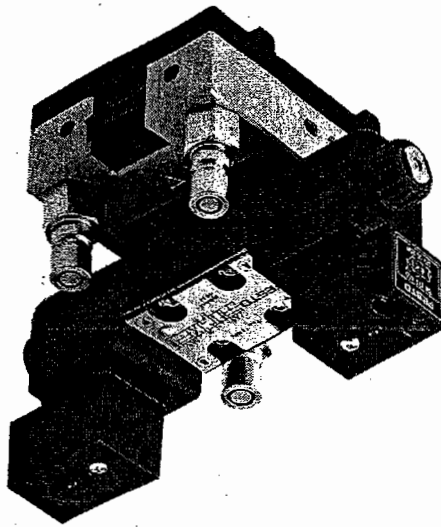
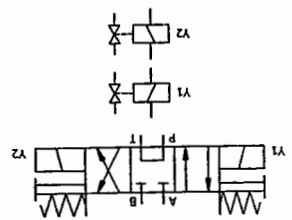

Design

The 4/3-way solenoid valve is mounted on a function plate equipped with four quick coupling connectors. The component is fitted to the grid system of the slotted assembly board by means of the two blue levers (mounting variant "A").  
 The valve consists of: Piston (1), housing (2), spring (2), solenoid coil Y2(4), plunger (5) and (8), stem (6), solenoid coil Y1 (7), emergency manual override (9), nut (10), pressure relieving groove (12), pressure tube (11), pressure relieving groove (12), transverse bore (13), piston chamber (14) and (15).

Function

This directional control valve comprises 3 switching positions for the control of flow rates and is directly actuated by DC solenoid coils. Characteristic of this valve is the mid-position, whereby ports A and B are closed and ports T and P interconnected. The valve is shown in the mid-position in the sectional view, whereby ports A and B are closed. Port P is connected to the chambers (14) and (15) via the transverse bores in the piston (1) and from there to port T via a transverse bore (13). The valve assumes the mid-position via the two compression springs, if neither of the two solenoids are energised (spring force). If voltage is applied to the solenoid coil Y2 (4), the plunger (5) presses the piston (1) spring against the spring opposite via the stem. This connects port P to port B via the piston chamber (14) and at the same time port A to port T via the piston chamber (15). By energising the solenoid coil Y1 (7), the piston is pushed in the opposite direction, whereby port P is connected to port A via the piston chamber (15) and port B is simultaneously connected to port T via the piston chamber (15). The switching solenoid consists of the pressure tube (11), the push-on coil body which is attached by the nut (10) and the stem (6). The electrical connection is effected via a valve plug socket. An emergency manual override (9) also facilitates actuation without electrical energy. The pressure relieving groove (10) reduces the peripheral lateral forces, whereby static friction at high pressures can be considerably reduced.

Pressure-drop/flow-rate characteristic

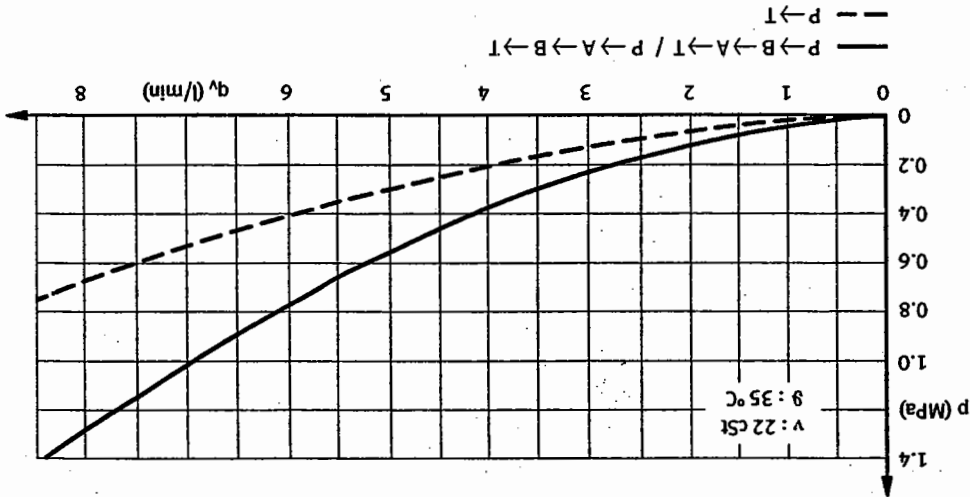

Note

The valve ports are identified by letters.  
 A, B Working ports  
 P Supply port  
 T Return-line port (tank connection)

The electrical connections are protected against overvoltage. The switching status is indicated by an LED.

The emergency manual override must not be actuated by means of sharp-edged objects (e.g. screwdrivers) so that its smooth operation and leak-proofness are maintained. A stiff manual override may result in malfunction of the solenoid valve.

Technical data

Hydraulic	
Medium	Mineral oil, recommended viscosity 22 cSt (mm <sup>2</sup> /s)
Operating pressure p	6 MPa (60 bar)
Max. permissible pressure p <sub>max</sub>	12 MPa (120 bar)
Voltage	24 V DC
Power rating	6.5 W
Actuation	Electrical
Connections, electrical	For 4 mm safety connector plug
Connections, hydraulic	For 4 coupling sockets

